

THS68

YALITIMLI KAPI-PENCERE SİSTEMİ
THERMAL WINDOW&DOOR SYSTEM

TÜRKAK
TÜRK AKREDİTASYON KURUMU
TURKISH ACCREDITATION AGENCY
İstanbul'da akredite edilmiş

FTI Fasad Teknoloji Merkezi / Façade Testing Institute
Merkez / Head Office
Paşaportçu Yolu, Sait Çarşısı Sok. No: 2, Sütlüce Plaza İş Merkezi Kat: 5/3405 Akatlar / Beşiktaş / TÜRKİYE
Tel: +90 212 438 92 21 Fax: +90 212 438 92 21 web: www.fti.org.tr

Laboratuvar / Laboratory
Çelik İnşaatlar Sanayi Parkı Sok. No:10 Kat:10/10 Çekirge / Beşiktaş / TÜRKİYE
Tel: +90 212 776 45 50 Fax: +90 212 776 45 50 web: www.ftilab.com.tr

DENEY SERTİFİKASI / Test Certificate

TÜRKAK
No: 04-0111
04-0111-0
08/18/2/2013
11/2013

Müşterinin Adı ve Adresi / Customer's Name & Address: **ASIST Alüminyum Profil A.Ş.**
Prof. Dr. Nevzat Piskacı Cad. Dağcı Sanayi Sitesi E Blok No: 3 Yenibosna / İstanbul / TÜRKİYE

Referans No / Reference No: **2013.217**

Numunenin Adı ve Türü / Sample's Name & Description: **Asistal TH68 Window and Door System (TİM & Turn)**

Numunenin Kabul Tarihi / Receipt Date of Test Item: **06.06.2013**

Uygulanan Normlar / Norms Applied: **TS EN 1026, TS EN 1027 and TS 4644 EN 12211**

Sonuçlar / Results: **Air Permeability: TS EN 12207 - Class 4 (600 Pa)**
Water-tightness: TS EN 12208 - Class 9A (600 Pa)
Wind Resistance: TS EN 12210 - Class C3

Test Tarihi / Date of Test: **26.10.2013** Sayfa Sayısı / Number of Pages: **1 / 14**

Türk Akreditasyon Kurumu (TÜRKAK) deney raporlarının tutumunu korumak üzere Akreditasyon Bölgesi (BA) ve Uluslararası Laboratuvar Akreditasyon Bölgesi (ILAC) ile karşılıklı tutum anlaşmaları imzalamıştır.
The Turkish Accreditation Agency (TÜRKAK) is signatory to the multilateral agreements of the European co-operation for the Accreditation (EA) and of the International Laboratory Accreditation (ILAC) for the Mutual recognition of test reports.

Uygulanan metodlar, test sonuçları ve güvenilirliği ilişkin detaylı bilgilere talep edilirse, bu sertifikasyon tutumunu koruyan ilgili rapor sayfalarında mevcuttur. Bu sertifika sadece test edilen numuneye ait sonuçları içerir ve diğer numunelerin ilgili raporları ile farklıdır.
The applied methods, test results and the uncertainty (if reported) with confidence probability are given on the following pages which are part of this report. The certificate includes the test specimens which is identified above and is valid with the related test report which is presented as annex.

Mühür / Seal: **FTI** Tarih / Date: **11.12.2013** Test Müh. / Testing Eng.: **M. Özgür Çelik** Lab. Müdürü / Lab. Manager: **Öktay Usta**

No Paper Laboratory report can be used for other than the purpose of the purchase of the laboratory. Respective reports without signature and seal are not valid.

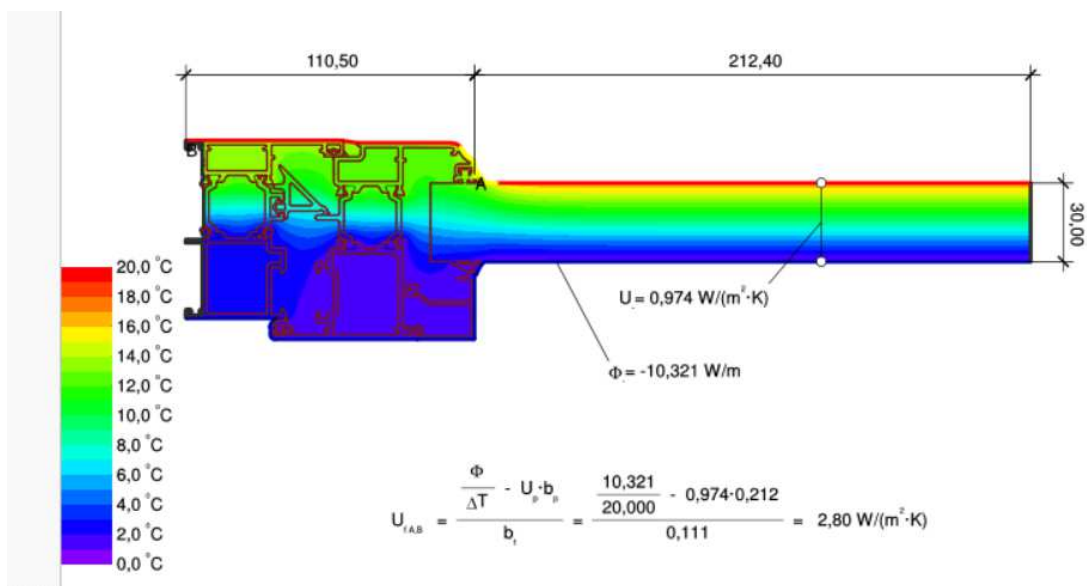

Uf değeri cam Ug değerine göre değişkenlik gösterir
Uf value can be change according to the glass Ug value

TH68 - 1,8mm

YALITIMLI KAPI-PENCERE SİSTEMİ
THERMAL WINDOW&DOOR SYSTEM

ASISTAL



PROFİL VE AKSESUAR LİSTELERİ
PROFILE & ACCESSORIES LISTS

TH68 - THS68 - 1,8mm/2mm

YALITIMLI KAPI-PENCERE SİSTEMİ
THERMAL WINDOW&DOOR SYSTEM

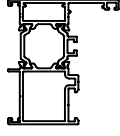
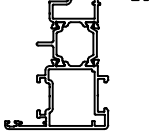
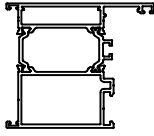
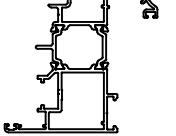
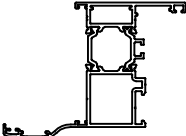
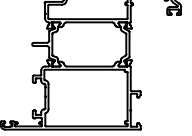
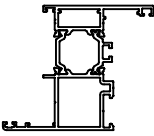
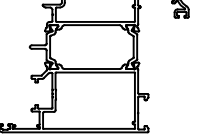
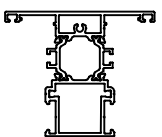
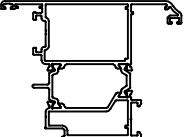
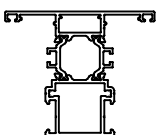
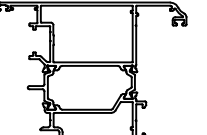
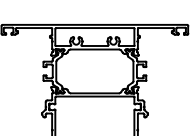
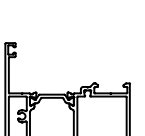
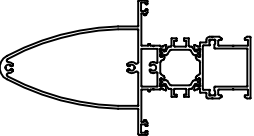

PROFİL LİSTESİ - PROFILES LIST

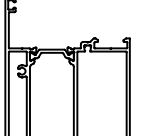
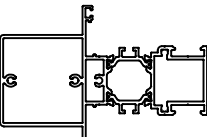
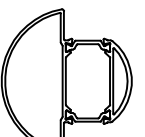
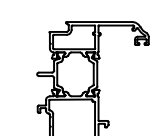
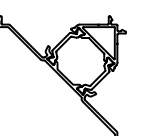
TH68 01	Jx cm ⁴	Jy cm ⁴		TH68 18	Jx cm ⁴	Jy cm ⁴	
	31,76	12,32			45,48	16,49	
KASA PROFİLİ-60 mm FRAME PROFILE	AĞIRLIK / Weight			KANAT PROFİLİ SASH PROFILE	AĞIRLIK / Weight		
	1,556 kg/mt				1,748 kg/mt		
TH68 02	Jx cm ⁴	Jy cm ⁴		TH68 14	Jx cm ⁴	Jy cm ⁴	
	41,14	34,21			48,74	23,14	
KASA PROFİLİ-80 mm FRAME PROFILE	AĞIRLIK / Weight			KANAT PROFİLİ MULTI POINT SİSTEM SASH PROFILE-MULTI POINT	AĞIRLIK / Weight		
	1,927 kg/mt				1,884 kg/mt		
TH68 03	Jx cm ⁴	Jy cm ⁴		TH68 12	Jx cm ⁴	Jy cm ⁴	
	43,77	26,72			57,09	45,77	
PERVAZLI KASA PROFİLİ FRAME PROFILE	AĞIRLIK / Weight			İÇE AÇILIR KAPI KANAT PROFİLİ INNER OPENING DOOR SASH PROFILE	AĞIRLIK / Weight		
	1,738 kg/mt				2,160 kg/mt		
TH68 04	Jx cm ⁴	Jy cm ⁴		TH68 15	Jx cm ⁴	Jy cm ⁴	
	38,23	18,04			60,11	54,41	
PERVAZLI KASA PROFİLİ FRAME PROFILE	AĞIRLIK / Weight			İÇE AÇILIR KAPI KANAT PROFİLİ-MULTI POINT INNER OPENING DOOR SASH PROFILE-MULTI POINT	AĞIRLIK / Weight		
	1,691 kg/mt				2,278 kg/mt		
TH68 21	Jx cm ⁴	Jy cm ⁴		TH68 13	Jx cm ⁴	Jy cm ⁴	
	36,07	18,77			56,07	45,85	
ORTA KAYIT PROFİLİ 81 mm (vidalı) TRANSOM-MULLION PROFILE	AĞIRLIK / Weight			DIŞA AÇILIR KAPI KANAT PROFİLİ OUTWARD OPENING DOOR SASH PROFILE	AĞIRLIK / Weight		
	1,774 kg/mt				2,190 kg/mt		
TH68 22	Jx cm ⁴	Jy cm ⁴		TH68 16	Jx cm ⁴	Jy cm ⁴	
	35,73	18,80			59,22	54,72	
ORTA KAYIT PROFİLİ 81 mm TRANSOM-MULLION PROFILE	AĞIRLIK / Weight			DIŞA AÇILIR KAPI KANAT PROFİLİ-MULTI POINT OUTWARD OPENING DOOR SASH PROFILE-MULTI POINT	AĞIRLIK / Weight		
	1,741 kg/mt				2,311 kg/mt		
TH68 23	Jx cm ⁴	Jy cm ⁴		TH68 31	Jx cm ⁴	Jy cm ⁴	
	46,21	47,09			131,71	65,85	
ORTA KAYIT PROFİLİ 102 mm TRANSOM-MULLION PROFILE	AĞIRLIK / Weight			ETEK PROFİLİ-130 mm BOTTOM PLATE PROFILE	AĞIRLIK / Weight		
	2,218 kg/mt				2,862 kg/mt		
TH68 24	Jx cm ⁴	Jy cm ⁴		12-37			
	189,09	30,06					
TAKVİYELİ ORTA KAYIT PROFİLİ SUPPORTED MULLION PROFILE	AĞIRLIK / Weight			EŞİK PROFİLİ BOTTOM RAIL PROFILE	AĞIRLIK / Weight		
	2,825 kg/mt				0,821 kg/mt		
TH68 25	Jx cm ⁴	Jy cm ⁴		TH68 52	Jx cm ⁴	Jy cm ⁴	
	107,86	29,63			29,52	30,21	
TAKVİYELİ ORTA KAYIT PROFİLİ SUPPORTED MULLION PROFILE	AĞIRLIK / Weight			EKSENEL DÖNÜŞ PROFİLİ CORNER PROFILE	AĞIRLIK / Weight		
	2,595 kg/mt				1,707 kg/mt		
TH68 11	Jx cm ⁴	Jy cm ⁴		TH68 53	Jx cm ⁴	Jy cm ⁴	
	45,68	18,36			30,95	34,82	
KANAT PROFİLİ SASH PROFILE	AĞIRLIK / Weight			90° KÖŞE PROFİLİ CORNER PROFILE	AĞIRLIK / Weight		
	1,765 kg/mt				1,562 kg/mt		

✳ Sipariş öncesi kalıp bilgisi kontrol edilmeli / must be check profile mold before the order

Profil ağırlıklarımız teorik olup; teslim anındaki tartımız geçerlidir.





TH68 - 1,8mm

YALITIMLI KAPI-PENCERE SİSTEMİ
THERMAL WINDOW&DOOR SYSTEM

ASISTAL

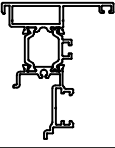
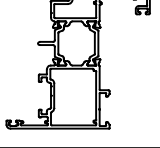
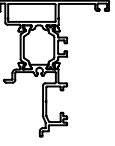
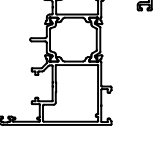
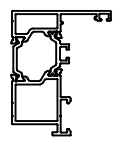
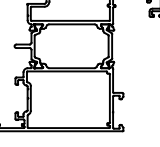
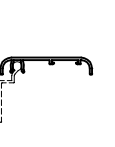
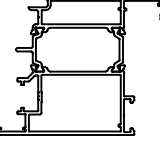
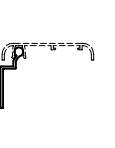
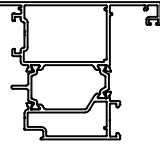
PROFİL LİSTESİ - PROFILES LIST

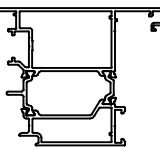
PROFİL LİSTESİ "S" SERİSİ - PROFILES LIST "S" SERIES

TH68 41				THS68 11	Jx cm ⁴ 46,64	Jy cm ⁴ 19,44	
ÇİFT KANAT ADAPTÖR PROFİLİ DOUBLE SASH ADAPTER PROFILE	AĞIRLIK / Weight 1,346 kg/mt			KANAT PROFİLİ-DÜZ SASH PROFILE-FLAT	AĞIRLIK / Weight 1,783 kg/mt		
TH68 42				THS68 14	Jx cm ⁴ 49,70	Jy cm ⁴ 24,36	
ÇİFT KANAT ADAPTÖR PROFİLİ-MULTI POINT DOUBLE SASH ADAPTER PROFILE - MULTI POINT	AĞIRLIK / Weight 1,367 kg/mt			KANAT PROFİLİ-DÜZ MULTI POINT SİSTEM SASH PROFILE-MULTI POINT	AĞIRLIK / Weight 1,902 kg/mt		
TH68 43				THS68 12	Jx cm ⁴ 57,99	Jy cm ⁴ 47,45	
DIŞA AÇILIR KAPI ADAPTÖR PROFİLİ OUTWARD OPENING DOOR ADAPTER PROFILE	AĞIRLIK / Weight 1,429 kg/mt			İÇE AÇILIR KAPI KANAT PROFİLİ-DÜZ INNER OPENING DOOR SASH PROFILE-FLAT	AĞIRLIK / Weight 2,177 kg/mt		
12-52				THS68 15	Jx cm ⁴ 61,05	Jy cm ⁴ 56,25	
PERVAZ PROFİLİ BORDER PROFILE	AĞIRLIK / Weight 0,279 kg/mt			İÇE AÇILIR KAPI KANAT PROFİLİ-MULTI POINT INNER OPENING DOOR SASH PROFILE-MULTI POINT	AĞIRLIK / Weight 2,296 kg/mt		
12-53				THS68 13	Jx cm ⁴ 56,95	Jy cm ⁴ 47,56	
PERVAZ MONTAJ PROFİLİ BORDER FIXING PROFILE	AĞIRLIK / Weight 0,177 kg/mt			DIŞA AÇILIR KAPI KANAT PROFİLİ - DÜZ OUTWARD OPENING DOOR SASH PROFILE	AĞIRLIK / Weight 2,208 kg/mt		
12-54				THS68 16	Jx cm ⁴ 60,11	Jy cm ⁴ 56,60	
PERVAZ PROFİLİ BORDER PROFILE	AĞIRLIK / Weight 0,326 kg/mt			DIŞA AÇILIR KAPI KANAT PROFİLİ-MULTI POINT OUTWARD OPENING DOOR SASH PROFILE-MULTI POINT	AĞIRLIK / Weight 2,329 kg/mt		
12-41							
TİJ PROFİLİ SASH PROFILE	AĞIRLIK / Weight 0,118 kg/mt						
04-025025-12							
KASA T 'Sİ - 30 mm FRAME BORDER	AĞIRLIK / Weight 0,159 kg/mt						

Profil ağırlıklarımız teorik olup; teslim anındaki tartımız geçerlidir.

TH68 - THS68 - 1,8mm/2mm

YALITIMLI KAPI-PENCERE SİSTEMİ
THERMAL WINDOW&DOOR SYSTEM

ASISTAL

PROFİL LİSTESİ "2mm" İÇİN - PROFILES LIST FOR "2mm"

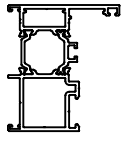
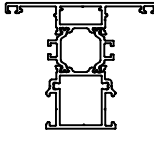
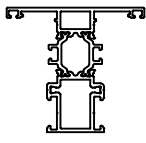
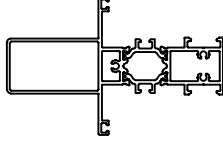
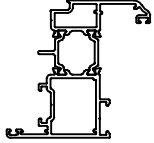
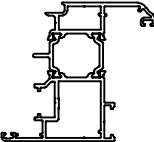
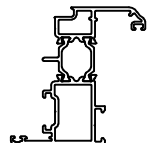
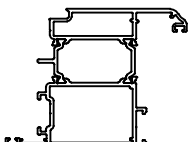
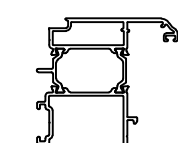
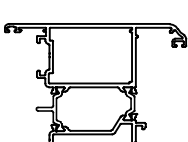
Model	Jx cm ⁴	Jy cm ⁴	Çizim	Model	Ağırlık / Weight
TH68 201	35,28	13,29		TH68 231	2mm - ETEK PROFİLİ BOTTOM PLATE PROFILE-2mm
KASA PROFİLİ-60 mm 2mm FRAME PROFILE	AĞIRLIK / Weight				
	1,678 kg/mt				3,121 kg/mt
TH68 222	40,04	20,87			
ORTA KAYIT PROFİLİ 81 mm - 2 mm TRANSOM-MULLION PROFILE	AĞIRLIK / Weight				
	1,875 kg/mt				
TH68 226	31,80	13,97			
ORTA KAYIT PROFİLİ 75 mm - 2 mm TRANSOM-MULLION PROFILE	AĞIRLIK / Weight				
	1,711 kg/mt				
TH68 225	94,09	16,52			
TAKVİYELİ ORTA KAYIT PROFİLİ- 2mm SUPPORTED MULLION PROFILE-2MM	AĞIRLIK / Weight				
	2,256 kg/mt				
TH68 211	46,64	19,44			
KANAT PROFİLİ-2mm SASH PROFILE	AĞIRLIK / Weight				
	1,863 kg/mt				
TH68 214	51,56	23,87			
KANAT PROFİLİ- 2 mm MULTI POINT SİSTEM SASH PROFILE-MULTI POINT	AĞIRLIK / Weight				
	1,983 kg/mt				
TH68 216	13,25	5,29			
KANAT PROFİLİ- 2 mm MULTI POINT SİSTEM SASH PROFILE-MULTI POINT	AĞIRLIK / Weight				
	1,719 kg/mt				
TH68 212	60,97	47,86			
İÇE AÇILIR KAPI KANAT PROFİLİ-2mm INNER OPENING DOOR SASH PROFILE-2mm	AĞIRLIK / Weight				
	2,295 kg/mt				
TH68 215	34,13	27,60			
İÇE AÇILIR KAPI-DAR KANAT PROFİLİ-2mm INNER OPENING DOOR SASH PROFILE-2mm	AĞIRLIK / Weight				
	2,145 kg/mt				
TH68 213					
2mm-DIŞA AÇILIR KAPI KANAT PROFİLİ OUTWARD OPENING DOOR SASH PROFILE - 2mm	AĞIRLIK / Weight				
	2,360 kg/mt				

Profil ağırlıklarımız teorik olup; teslim anındaki tartımız geçerlidir.

TH68 - THS68 - 1,8mm/2mm

YALITIMLI KAPI-PENCERE SİSTEMİ
THERMAL WINDOW&DOOR SYSTEM



PROFİL LİSTESİ - PROFILES LIST

10-010225-00			11-026		
KÖŞE TAKOZU-22,5 mm CORNER JOINT	AĞIRLIK / Weight 3,566 kg/mt		CAM ÇİTASI-26 mm GLAZING BEAD PROFILE	AĞIRLIK / Weight 0,296 kg/mt	
10-010429-00			11-028		
KÖŞE TAKOZU-42,7 mm CORNER JOINT	AĞIRLIK / Weight 5,483 kg/mt		CAM ÇİTASI-28 mm GLAZING BEAD PROFILE	AĞIRLIK / Weight 0,302 kg/mt	
12-91			11-030		
DİK BAĞLANTI T JOINT	AĞIRLIK / Weight 0,794 kg/mt		CAM ÇİTASI-30 mm GLAZING BEAD PROFILE	AĞIRLIK / Weight 0,308 kg/mt	
11-004			11-032		
CAM ÇİTASI-4 mm GLAZING BEAD PROFILE	AĞIRLIK / Weight 0,181 kg/mt		CAM ÇİTASI-32 mm GLAZING BEAD PROFILE	AĞIRLIK / Weight 0,315 kg/mt	
11-006			11-035		
CAM ÇİTASI-6 mm GLAZING BEAD PROFILE	AĞIRLIK / Weight 0,218 kg/mt		CAM ÇİTASI-35 mm GLAZING BEAD PROFILE	AĞIRLIK / Weight 0,323 kg/mt	
11-010			11-038		
CAM ÇİTASI-10 mm GLAZING BEAD PROFILE	AĞIRLIK / Weight 0,233 kg/mt		CAM ÇİTASI-38 mm GLAZING BEAD PROFILE	AĞIRLIK / Weight 0,334 kg/mt	
11-015			11-044		
CAM ÇİTASI-15 mm GLAZING BEAD PROFILE	AĞIRLIK / Weight 0,241 kg/mt		CAM ÇİTASI-44 mm GLAZING BEAD PROFILE	AĞIRLIK / Weight 0,338 kg/mt	
11-017			12-01		
CAM ÇİTASI-17 mm GLAZING BEAD PROFILE	AĞIRLIK / Weight 0,250 kg/mt		DAMLALIK PROFİLİ RAINDROP PROFILE	AĞIRLIK / Weight 0,198 kg/mt	
11-020			12-02		
CAM ÇİTASI-20 mm GLAZING BEAD PROFILE	AĞIRLIK / Weight 0,276 kg/mt		DAMLALIK PROFİLİ RAINDROP PROFILE	AĞIRLIK / Weight 0,136 kg/mt	
11-022			12-03		
CAM ÇİTASI-22 mm GLAZING BEAD PROFILE	AĞIRLIK / Weight 0,282 kg/mt		DAMLALIK PROFİLİ RAINDROP PROFILE	AĞIRLIK / Weight 0,313 kg/mt	

Profil ağırlıklarımız teorik olup; teslim anındaki tartımız geçerlidir.

EP1-01			ASI-H 9730		
DIŞ CAM FİTİLİ - 2,5 mm <i>OUTER GLAZING GASKET</i>	KOLİ MİKTARI/Package 240 mt / 15 kg		SİSTEM İKİLİ MENTEŞE <i>DOUBLE SYSTEM HINGE</i>	KOLİ MİKTARI/Package 250 Adet / Piece	
EP2-01			ASI-H 9733		
İÇ CAM FİTİLİ - 3 mm <i>INNER GLAZING GASKET</i>	KOLİ MİKTARI/Package 440 mt / 15 kg		SİSTEM ÜÇLÜ MENTEŞE <i>TRIPLE SYSTEM HINGE</i>	KOLİ MİKTARI/Package 250 Adet / Piece	
EP2-02			ASI-H 3300		
İÇ CAM FİTİLİ - 4 mm <i>INNER GLAZING GASKET</i>	KOLİ MİKTARI/Package 300 mt / 15 kg		SİSTEM KAPI MENTEŞESİ <i>SYSTEM DOOR HINGE</i>	KOLİ MİKTARI/Package Adet / Piece	
EP2-03			ASI-V 820		
İÇ CAM FİTİLİ - 5 mm <i>INNER GLAZING GASKET</i>	KOLİ MİKTARI/Package 250 mt / 15 kg		VASİSTAS AÇILIM KOLU <i>TRANSOM OPENING HANDLE</i>	KOLİ MİKTARI/Package 30 Adet / Piece	
EP4-13			ASI-V 816		
ORTA BİNİ FİTİLİ <i>GASKET FOR OPEN JOINT</i>	KOLİ MİKTARI/Package 100 mt / 15 kg		VASİSTAS AÇILIM KOLU <i>TRANSOM OPENING HANDLE</i>	KOLİ MİKTARI/Package 50 Adet / Piece	
EP4-13K			ASI-V 1000		
VULKANİZE FİTİLİ <i>GASKET FOR CORNER</i>	KOLİ MİKTARI/Package Adet / Piece		VASİSTAS MAKAS (PVC) <i>TRANSOM RESTRICTER</i>	KOLİ MİKTARI/Package 120 Adet / Piece	
EP3-01			ASI-V 1080		
KANAT BİNİ FİTİLİ <i>SASH GASKET</i>	KOLİ MİKTARI/Package 430 mt / 15 kg		VASİSTAS MAKAS <i>TRANSOM RESTRICTER</i>	KOLİ MİKTARI/Package 60 Adet / Piece	
EP3-02			ASI-V 1275-3		
KASA BİNİ FİTİLİ <i>FRAME GASKET</i>	KOLİ MİKTARI/Package 750 mt / 15 kg		VASİSTAS 3 KADEMELİ ÇELİK MAKAS <i>TRANSOM RESTRICTER WITH 3 POSITIONS</i>	KOLİ MİKTARI/Package 10 Adet / Piece	
EP3-03			ASI-V 1275-5		
KASA BİNİ FİTİLİ <i>FRAME GASKET</i>	KOLİ MİKTARI/Package		VASİSTAS 5 KADEMELİ ÇELİK MAKAS <i>TRANSOM RESTRICTER WITH 5 POSITIONS</i>	KOLİ MİKTARI/Package 10 Adet / Piece	
TH68 HOK			ASI-V 0148		
ADAPTÖR KAPAĞI <i>ADAPTER COVER</i>	KOLİ MİKTARI/Package alt-üst 1 takım		VASİSTAS ÇELİK MAKAS <i>TRANSOM STEEL RESTRICTER</i>	KOLİ MİKTARI/Package 100 Adet / Piece	

TH68 - THS68 - 1,8mm/2mm

YALITIMLI KAPI-PENCERE SİSTEMİ
THERMAL WINDOW&DOOR SYSTEM



AKSESUAR LİSTESİ - ACCESSORIES LIST

ASI-WH 003		ASI-RP 001	
TEK DİLLİ EKSENEL KOL WINDOW HANDLE	KOLİ MİKTARI/Package Adet / Piece	TIJ PİMİ ROD PROFILE LOCKING	KOLİ MİKTARI/Package Adet / Piece
ASI-WH 004		ASI-RS 001	
ÇİFT DİLLİ EKSENEL KOL WINDOW HANDLE	KOLİ MİKTARI/Package Adet / Piece	PİM KARŞILIĞI ROD PROFILE STRIKES	KOLİ MİKTARI/Package 120 Adet / Piece
ASI-WH 004A		ASI-153 35	
ÇİFT DİLLİ EKSENEL KOL - ANAHTARLI WINDOW HANDLE WITH LOCK	KOLİ MİKTARI/Package Adet / Piece	DİLLİ KİLİT MOURTISE LOCK WITH CYLINDER	KOLİ MİKTARI/Package Adet / Piece
ASI-KA M108		ASI-LS 90185D	
EKSENEL KOL KİLİTLEME MEKANİZMASI LOCKING FOR WINDOW	KOLİ MİKTARI/Package Adet / Piece	DİLLİ KİLİT KARŞILIĞI LOCK STRIKES	KOLİ MİKTARI/Package Adet / Piece
ASI-KA P200		ASI-155 35	
EKSENEL KOL KİLİTLEME MEKANİZMASI LOCKING FOR WINDOW	KOLİ MİKTARI/Package Adet / Piece	MAKARALI KİLİT MOURTISE LOCK WITH ROLLER	KOLİ MİKTARI/Package Adet / Piece
ASI-KA VNT		ASI-LS 90185M	
KANAT SABİTLEME SASH FIXING	KOLİ MİKTARI/Package Adet / Piece	MAKARALI KİLİT KARŞILIĞI ROLLER LOCK STRIKES	KOLİ MİKTARI/Package Adet / Piece
ASI-WH 001		ASI-BRL 90	
KARE MİLLİ PENCERE KOLU WINDOW HANDLE	KOLİ MİKTARI/Package Adet / Piece	90 LİK BAREL CYLINDER 90	KOLİ MİKTARI/Package 250 Adet / Piece
ASI-WH 001A		ASI-B 2217	
KARE MİLLİ PENCERE KOLU-ANAHTARLI WINDOW HANDLE WITH LOCK	KOLİ MİKTARI/Package Adet / Piece	SÜRGÜ KİLİTLEME-KISA SASH FIXING LOCK-SHORT	KOLİ MİKTARI/Package 240 Adet / Piece
ASI-WH 001B		ASI-B 2215	
KARE MİLLİ PENCERE KOLU - İKİLİ TAKIM WINDOW HANDLE WITH LOCK	KOLİ MİKTARI/Package Takım / Set	SÜRGÜ KİLİTLEME-UZUN SASH FIXING LOCK-LONG	KOLİ MİKTARI/Package 120 Adet / Piece
ASI-DH 002		ASI-DH 60Y	
KAPI KOLU DOOR HANDLE	KOLİ MİKTARI/Package Adet / Piece	ÇEKME KAPI KOLU DOOR HANDLE	KOLİ MİKTARI/Package Adet / Piece

TH68 - THS68 - 1,8mm/2mm

YALITIMLI KAPI-PENCERE SİSTEMİ
THERMAL WINDOW&DOOR SYSTEM







AKSESUAR LİSTESİ - ACCESSORIES LIST

KF 67-1000			ASI-P 100.1		
FIRÇA FİTİL <i>BRUSH GASKET</i>	KOLİ MİKTARI/Package 600 mt		ORTA KAYIT BAĞLANTI <i>T JOINT</i>	KOLİ MİKTARI/Package 250 Adet / Piece	
ASI-F 100A			ASI-DB 9174		
KAPI ALTI FIRÇASI <i>DOOR BRUSH GASKET</i>	KOLİ MİKTARI/Package Adet / Piece		DİK BAĞLANTI <i>T JOINT</i>	KOLİ MİKTARI/Package Adet / Piece	
ASI-WDC 01			ASI-DB 9116		
YAĞMUR TAHLİYE KAPAĞI <i>WATER REJECT COVER</i>	KOLİ MİKTARI/Package Adet / Piece		DİK BAĞLANTI <i>T JOINT</i>	KOLİ MİKTARI/Package Adet / Piece	
ASI-WDC 02			ASI-DB 9143		
KLAPELİ YAĞMUR TAHLİYE KAPAĞI <i>WATER REJECT COVER</i>	KOLİ MİKTARI/Package Adet / Piece		DİK BAĞLANTI <i>T JOINT</i>	KOLİ MİKTARI/Package Adet / Piece	
ASI-FUJI 2400			ASI-DB 9123		
AYARLI ORTA KAYIT BAĞLANTI <i>T JOINT CONNECTION</i>	KOLİ MİKTARI/Package Adet / Piece		DİK BAĞLANTI <i>T JOINT</i>	KOLİ MİKTARI/Package Adet / Piece	
ASI-FUJI 2700			ASI-ALU TT		
AYARLI ORTA KAYIT BAĞLANTI <i>T JOINT CONNECTION</i>	KOLİ MİKTARI/Package Adet / Piece		ÇİFT EKSEN AÇILIM MEKANİZMASI <i>TILT&TURN OPENING</i>	KOLİ MİKTARI/Package Takım / Set	
ASI-FUJI 2000			ASI-PVC TT		
AYARLI KÖŞE GÖNYESİ <i>CORNER ALIGNMENT</i>	KOLİ MİKTARI/Package Adet / Piece		ÇİFT EKSEN AÇILIM MEKANİZMASI <i>TILT&TURN OPENING</i>	KOLİ MİKTARI/Package Takım / Set	
ASI-SB 19			ASI-MEK VW		
KÖŞE GÖNYESİ <i>CORNER ALIGNMENT</i>	KOLİ MİKTARI/Package 1000 Adet / Piece		PARALEL SÜRME MEKANİZMASI <i>TILT&SLIDE OPENING</i>	KOLİ MİKTARI/Package Takım / Set	
ASI-SB 19.1			SG50-TH62-01		
KÖŞE GÖNYESİ <i>CORNER ALIGNMENT</i>	KOLİ MİKTARI/Package 1000 Adet / Piece		KANAT CAM TAKOZU <i>GLASS SUPPORT FOR SASH</i>	KOLİ MİKTARI/Package Adet / Piece	
ASI-SS 01			SG50-TH62-02		
KANAT DESTEK TAKOZU <i>SASH SUPPORT BOTTOM</i>	KOLİ MİKTARI/Package Takım / Set		KASA CAM TAKOZU <i>GLASS SUPPORT FOR FRAME</i>	KOLİ MİKTARI/Package Adet / Piece	

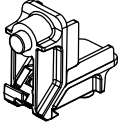
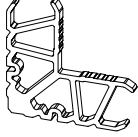
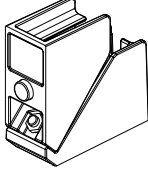
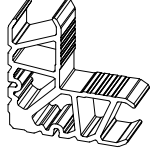
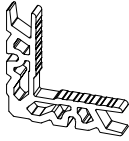
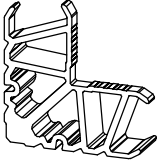
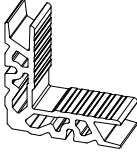
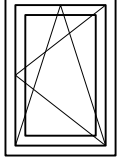
⚠ Sipariş öncesi kalıp bilgisi kontrol edilmeli / *must be check profile mold before the order*

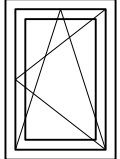
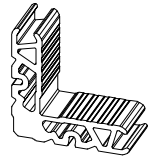
AKSESUAR LİSTESİ - ACCESSORIES LIST

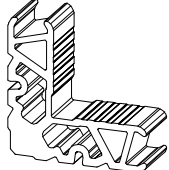
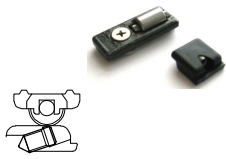
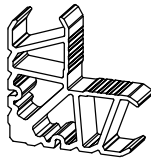
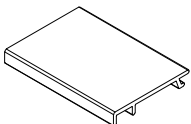
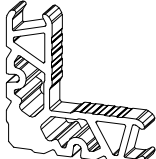
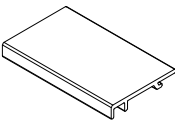
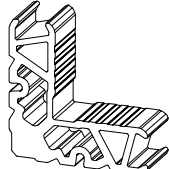
ASI-PB 2326			ASI-KT 3807		
PİMLİ KÖŞE BAĞLANTI CORNER JOINT	KOLİ MİKTARI/Package 200 Adet / Piece		KÖŞE TAKOZU CORNER JOINT	KOLİ MİKTARI/Package Adet / Piece	
ASI-PB 2650			ASI-KT 3830		
PİMLİ KÖŞE BAĞLANTI CORNER JOINT	KOLİ MİKTARI/Package 150 Adet / Piece		KÖŞE TAKOZU CORNER JOINT	KOLİ MİKTARI/Package Adet / Piece	
ASI-KT 1609			ASI-KT 4308		
KÖŞE TAKOZU CORNER JOINT	KOLİ MİKTARI/Package Adet / Piece		KÖŞE TAKOZU CORNER JOINT	KOLİ MİKTARI/Package Adet / Piece	
ASI-KT 1626			ASI-ALU TT		
KÖŞE TAKOZU CORNER JOINT	KOLİ MİKTARI/Package Adet / Piece		ÇİFT EKSEN AÇILIM MEKANİZMASI TILT&TURN OPENING	KOLİ MİKTARI/Package Takım / Set	
ASI-KT 1807			ASI-PVC TT		
KÖŞE TAKOZU CORNER JOINT	KOLİ MİKTARI/Package Adet / Piece		ÇİFT EKSEN AÇILIM MEKANİZMASI TILT&TURN OPENING	KOLİ MİKTARI/Package Takım / Set	
ASI-KT 1830			ASI-MEK VW		
KÖŞE TAKOZU CORNER JOINT	KOLİ MİKTARI/Package Adet / Piece		PARALEL SÜRME MEKANİZMASI TILT&SLIDE OPENING	KOLİ MİKTARI/Package Takım / Set	
ASI-KT 2660			ASI-SS 01		
KÖŞE TAKOZU CORNER JOINT	KOLİ MİKTARI/Package Adet / Piece		KANAT DESTEK TAKOZU SASH SUPPORT BOTTOM	KOLİ MİKTARI/Package Takım / Set	
ASI-KT 2650			SG50-TH62-01		
KÖŞE TAKOZU CORNER JOINT	KOLİ MİKTARI/Package Adet / Piece		KANAT CAM TAKOZU GLASS SUPPORT FOR SASH	KOLİ MİKTARI/Package Adet / Piece	
ASI-KT 2308			SG50-TH62-02		
KÖŞE TAKOZU CORNER JOINT	KOLİ MİKTARI/Package Adet / Piece		KASA CAM TAKOZU GLASS SUPPORT FOR FRAME	KOLİ MİKTARI/Package Adet / Piece	
ASI-KT 2319					
KÖŞE TAKOZU CORNER JOINT	KOLİ MİKTARI/Package Adet / Piece				

TH68 - 1,8mm

YALITIMLI KAPI-PENCERE SİSTEMİ
THERMAL WINDOW&DOOR SYSTEM

ASISTAL





PROFİL DETAYLARI
PROFILE DETAILS

TH68 - 1,8mm

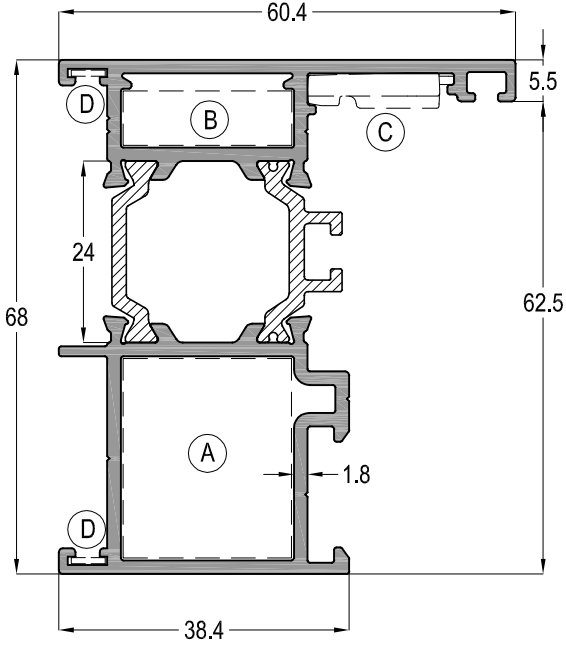



YALITIMLI KAPI-PENCERE SİSTEMİ
THERMAL WINDOW&DOOR SYSTEM

ASISTAL

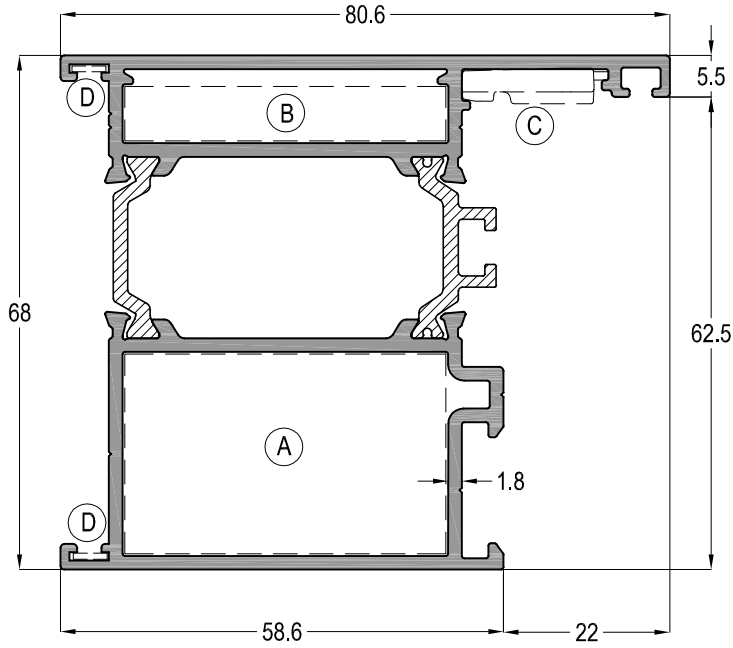

TH68 01				Jx cm ⁴	Jy cm ⁴
				31,76	12,32
 (A)	 (B)	 (C)	 (D)	AĞIRLIK / Weight	
ASI-KT 2660-ASI-PB 2326	ASI-KT 2308	ASI-FUJII 2000	ASI-SB 19	1,556 kg/mt	



TH68 02				Jx cm ⁴	Jy cm ⁴
				41,14	34,21
 (A)	 (B)	 (C)	 (D)	AĞIRLIK / Weight	
ASI-KT 2650-ASI-PB 2650	ASI-KT 4308	ASI-FUJII 2000	ASI-SB 19	1,927 kg/mt	

TH68 - 1,8mm

YALITIMLI KAPLI-PENCERE SİSTEMİ
THERMAL WINDOW&DOOR SYSTEM

ASISTAL

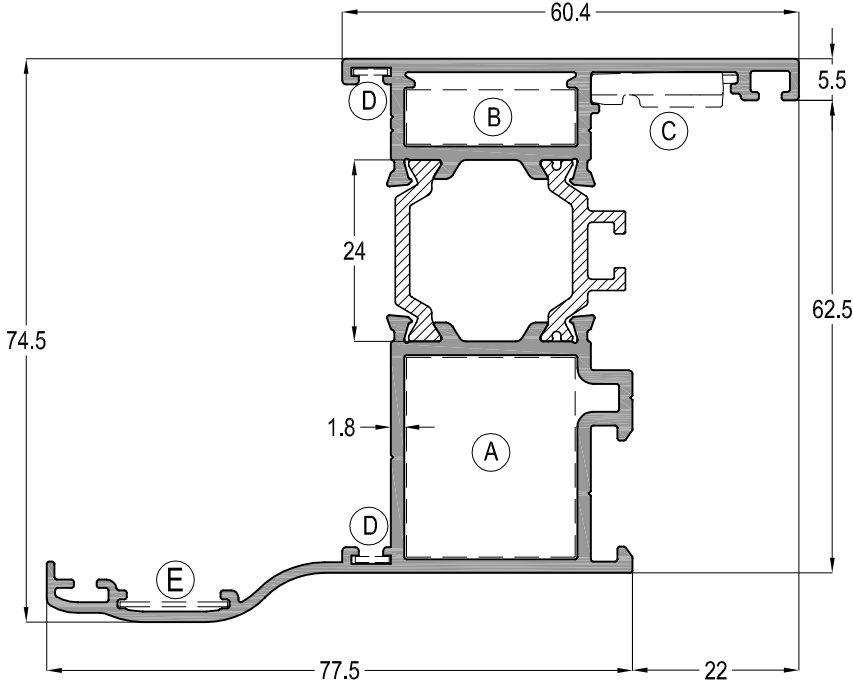

TH68 03				Jx cm ⁴	Jy cm ⁴
				43,77	26,72
				AĞIRLIK / Weight	
				1,738 kg/mt	

A	B	C	E
ASI-KT 2660-ASI-PB 2326	ASI-KT 2308	ASI-FUJII 2000	ASI-SB 19.1

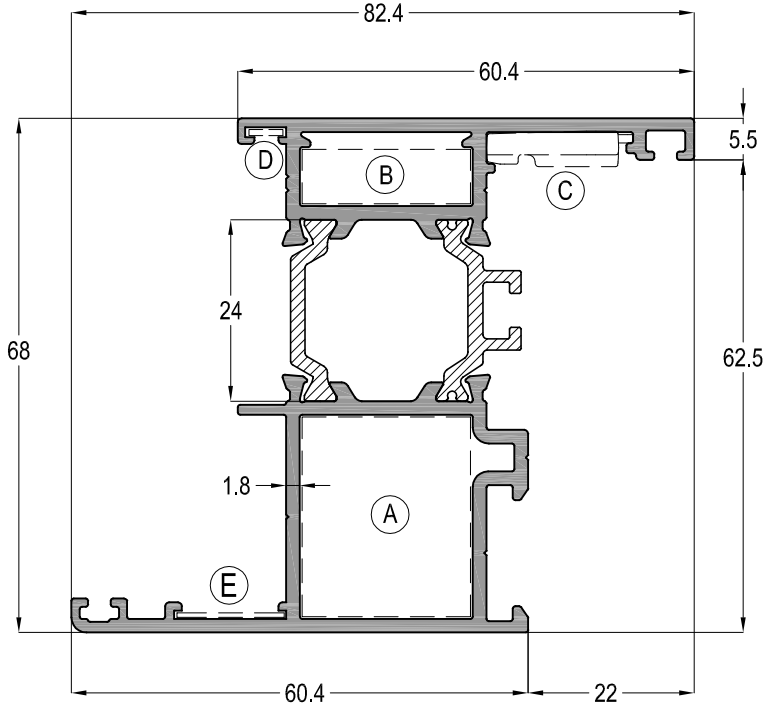

TH68 04				Jx cm ⁴	Jy cm ⁴
				38,23	18,04
				AĞIRLIK / Weight	
				1,691 kg/mt	



A	B	C	E
ASI-KT 2660-ASI-PB 2326	ASI-KT 2308	ASI-FUJII 2000	ASI-SB 19.1

TH68 - 1,8mm



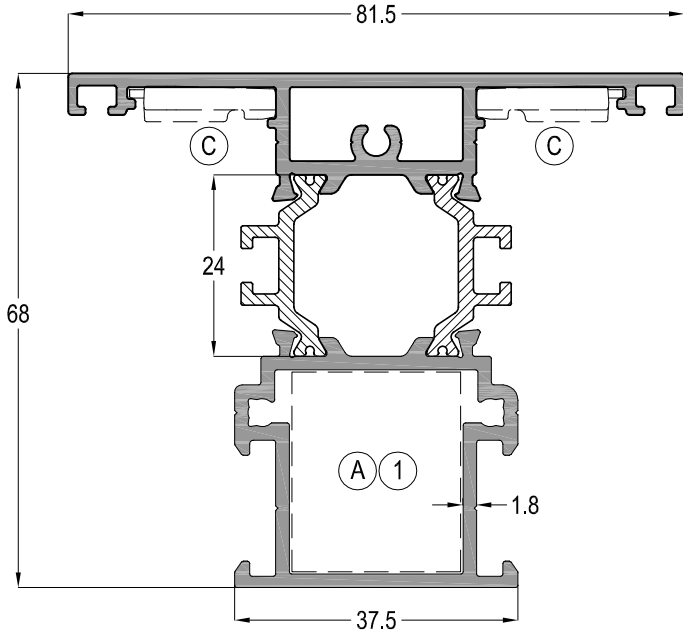

YALITIMLI KAPI-PENCERE SİSTEMİ
THERMAL WINDOW&DOOR SYSTEM

ASISTAL

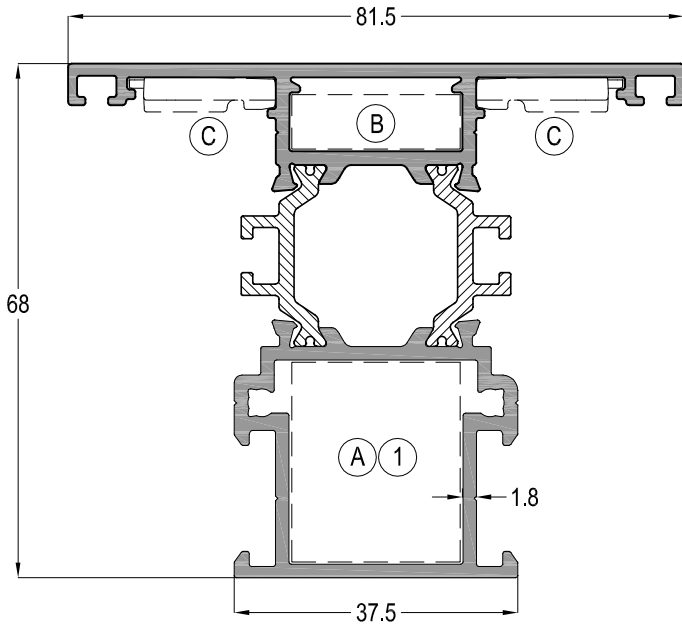



TH68 21			Jx cm ⁴	Jy cm ⁴
			36,07	18,77
 (A)	 (C)	 (1)	AĞIRLIK / Weight	
ASI-KT 2660-ASI-PB 2326	ASI-FUJI 2000	ASI-DB 9123	1,774 kg/mt	

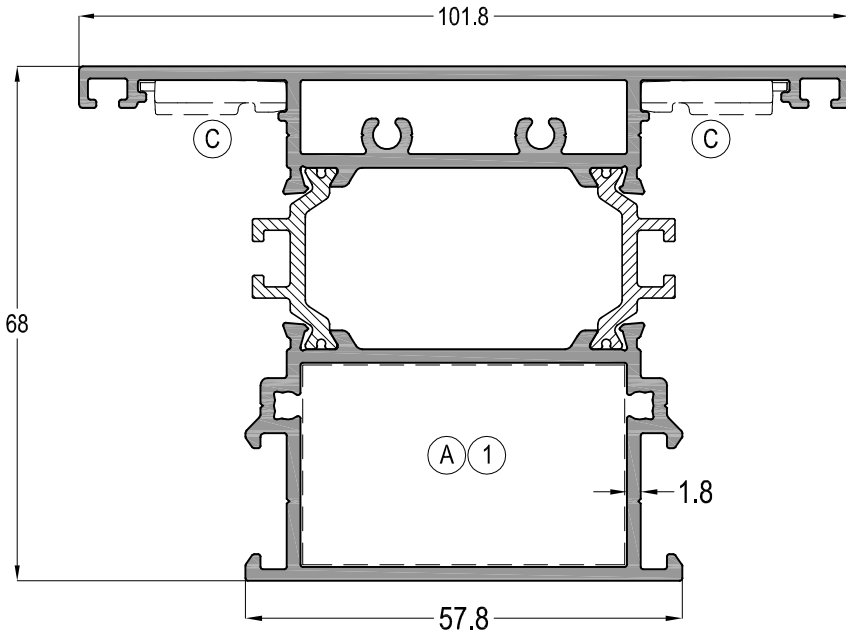

TH68 22				Jx cm ⁴	Jy cm ⁴
				35,73	18,80
 (A)	 (B)	 (C)	 (1)	AĞIRLIK / Weight	
ASI-KT 2660-ASI-PB 2326	ASI-KT 2308	ASI-FUJI 2000	ASI-DB 9123	1,741 kg/mt	



TH68 23			Jx cm ⁴	Jy cm ⁴
			46,21	47,09
 (A)	 (C)	 (1)	AĞIRLIK / Weight	
ASI-KT 2650-ASI-PB 2650	ASI-FUJI 2000	ASI-DB 9143	2,218 kg/mt	

Profil ağırlıklarımız teorik olup; teslim anındaki tartımımız geçerlidir.

TH68 - 1,8mm

YALITIMLI KAPI-PENCERE SİSTEMİ
THERMAL WINDOW&DOOR SYSTEM



TH68 24	Jx cm ⁴	Jy cm ⁴
	189,09	30,06
 ASI-DB 9123	AĞIRLIK / Weight	
	2,825 kg/mt	

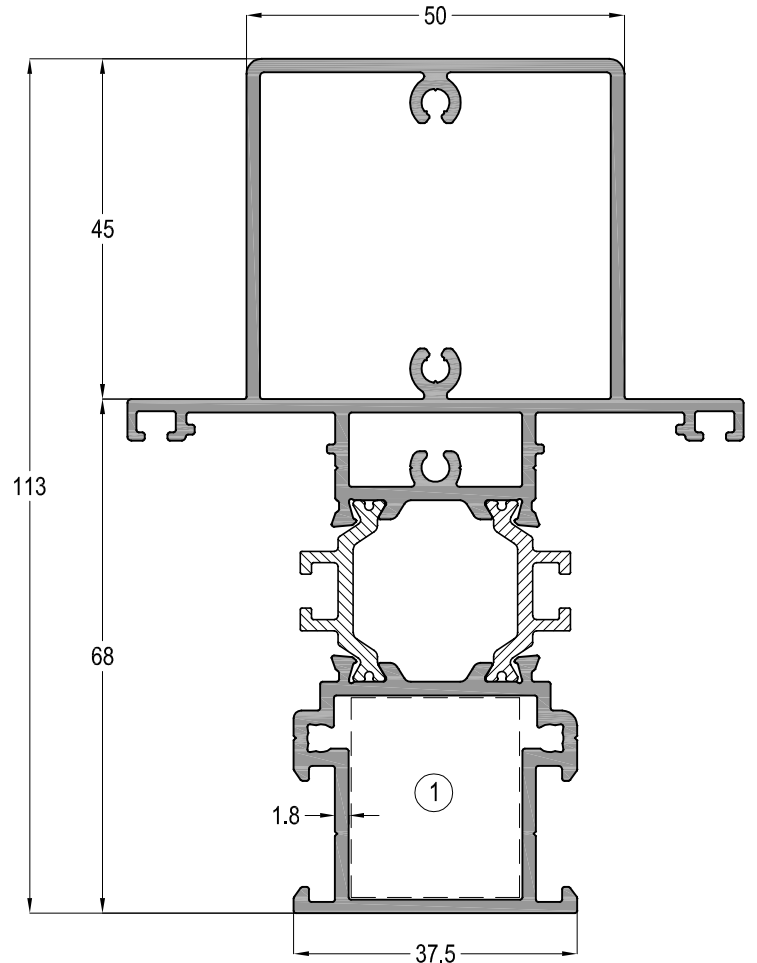
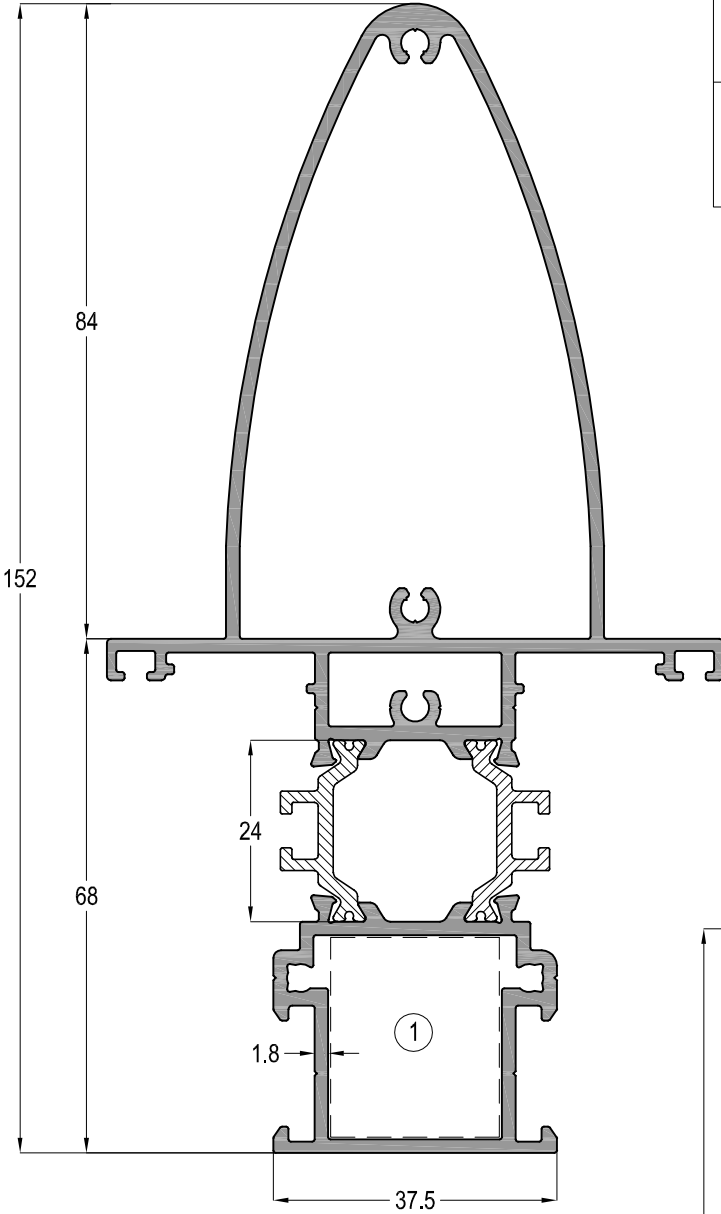

TH68 25	Jx cm ⁴	Jy cm ⁴
	107,86	29,63
 ASI-DB 9123	AĞIRLIK / Weight	
	2,595 kg/mt	

Profil ağırlıklarımız teorik olup; teslim anındaki tartımız geçerlidir.

TH68 - 1,8mm

YALITIMLI KAPI-PENCERE SİSTEMİ
THERMAL WINDOW&DOOR SYSTEM

ASISTAL

THS SERİSİ DÜZ KANAT PROFİLLERİ THS SERIES FLAT SASH PROFILES

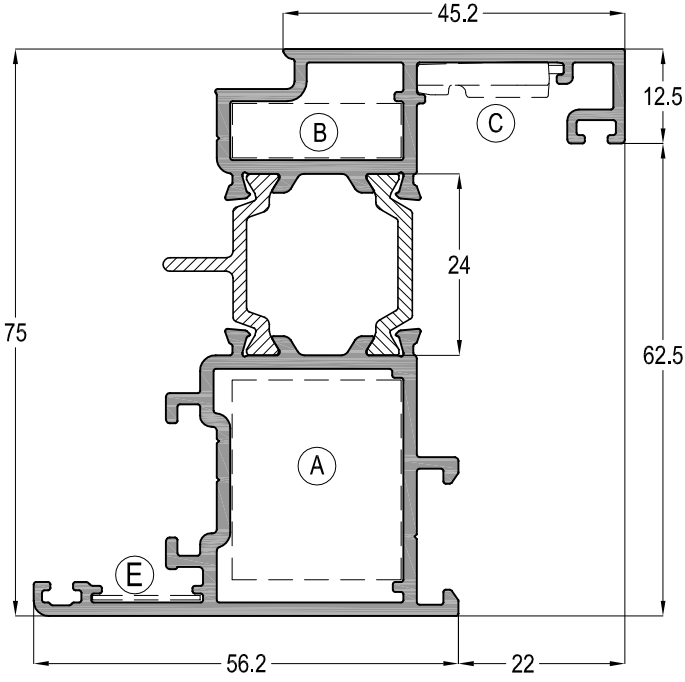

THS68 11		Jx cm ⁴	Jy cm ⁴
		46,64	19,44
AĞIRLIK / Weight			
		1,783 kg/mt	

ASI-KT 2660-ASI-PB 2326 | ASI-KT 2308 | ASI-FUJII 2000 | ASI-SB 19.1

THS68 12		Jx cm ⁴	Jy cm ⁴
		57,99	47,45
AĞIRLIK / Weight			
		2,177 kg/mt	

ASI-KT 2650-ASI-PB 2650 | ASI-KT 4308 | ASI-FUJII 2000 | ASI-SB 19.1

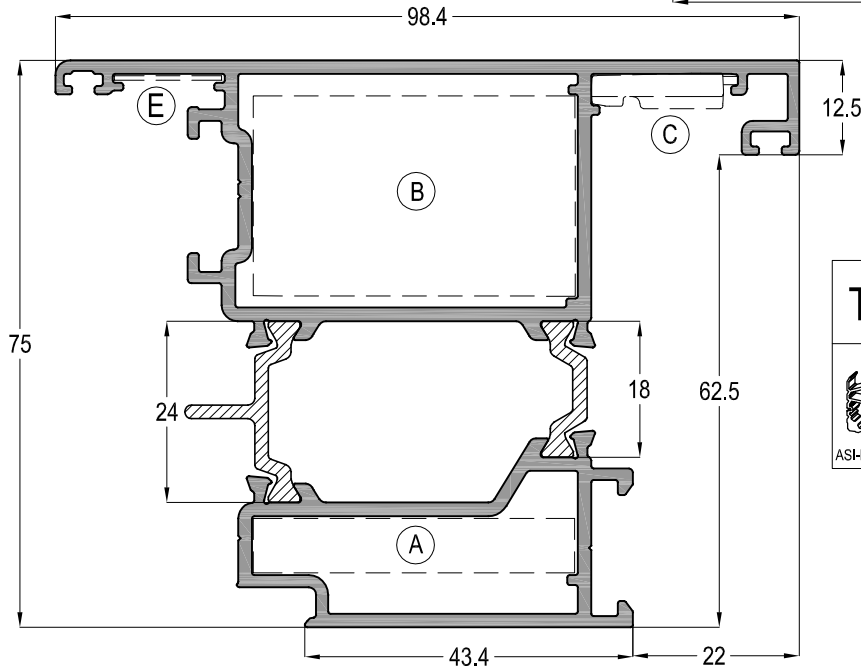
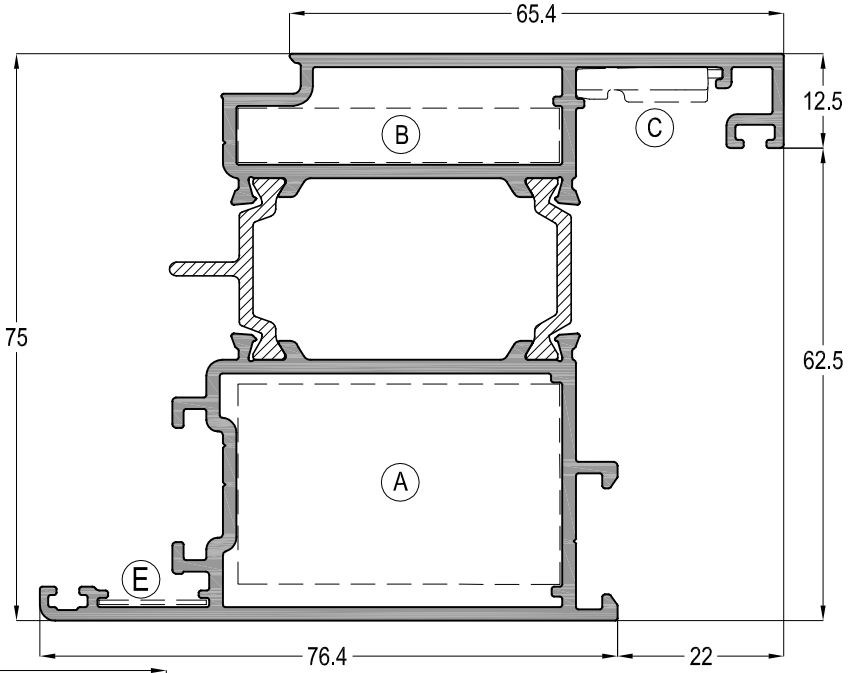

THS68 13		Jx cm ⁴	Jy cm ⁴
		56,95	47,56
AĞIRLIK / Weight			
		2,208 kg/mt	

ASI-KT 2650-ASI-PB 2650 | ASI-KT 4308 | ASI-FUJII 2000 | ASI-SB 19.1

Profil ağırlıklarımız teorik olup; teslim anındaki tartımız geçerlidir.

TH68 - THS68

YALITIMLI KAPI-PENCERE SİSTEMİ
THERMAL WINDOW&DOOR SYSTEM

ASISTAL

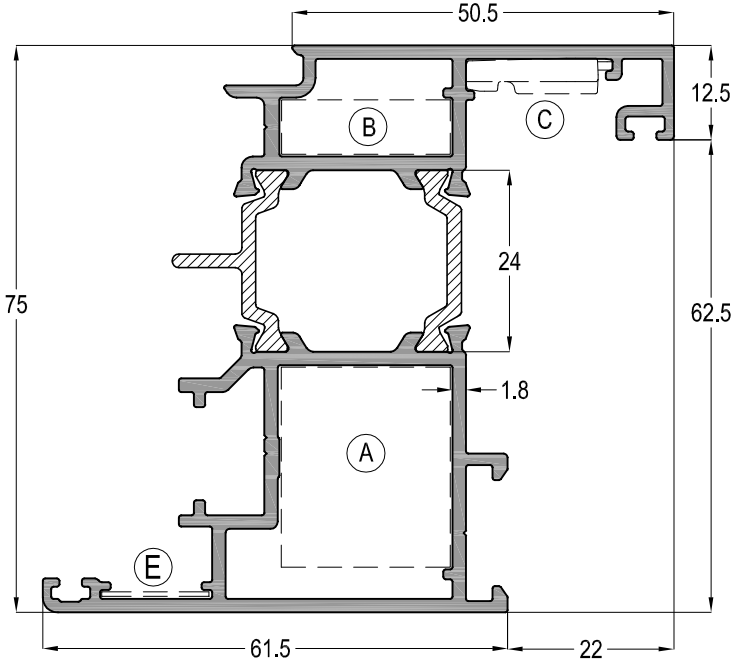

THS SERİSİ ÇOK NOKTADAN KİLİTLEME KANAT PROFİLLERİ THS SERIES MULTI POINT LOCK SASH PROFILES

THS68 14	Jx cm ⁴	Jy cm ⁴
	49,70	24,36
AĞIRLIK / Weight		1,902 kg/mt

ASI-KT 2660-ASI-PB 2326 | ASI-KT 2308 | ASI-FUJJI 2000 | ASI-SB 19.1

THS68 15	Jx cm ⁴	Jy cm ⁴
	61,05	56,25
AĞIRLIK / Weight		2,296 kg/mt

ASI-KT 2650-ASI-PB 2650 | ASI-KT 4308 | ASI-FUJJI 2000 | ASI-SB 19.1

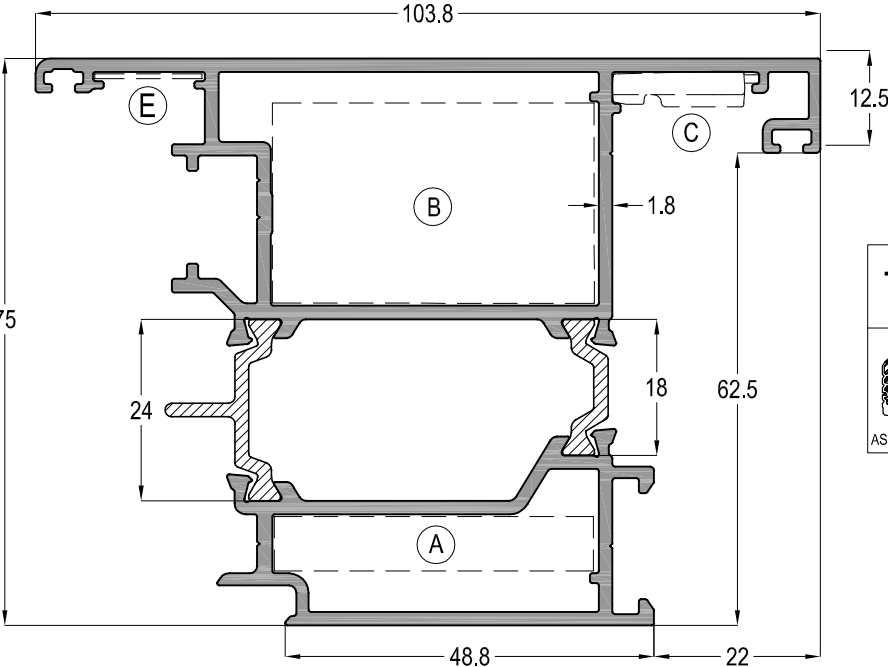
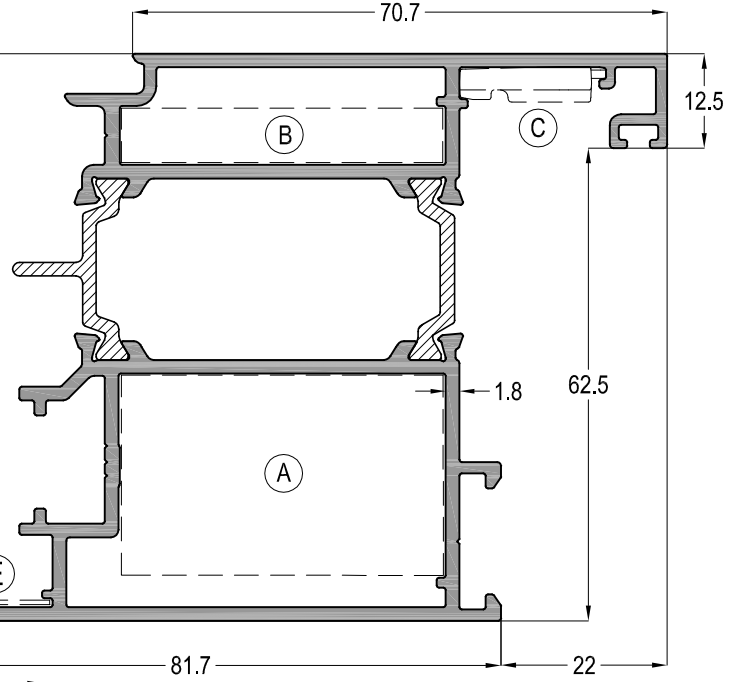

THS68 16	Jx cm ⁴	Jy cm ⁴
	60,11	56,60
AĞIRLIK / Weight		2,329 kg/mt

ASI-KT 2650-ASI-PB 2650 | ASI-KT 4308 | ASI-FUJJI 2000 | ASI-SB 19.1

Profil ağırlıklarımız teorik olup; teslim anındaki tartımız geçerlidir.

TH68 - 1,8mm



YALITIMLI KAPI-PENCERE SİSTEMİ
THERMAL WINDOW&DOOR SYSTEM

ASISTAL



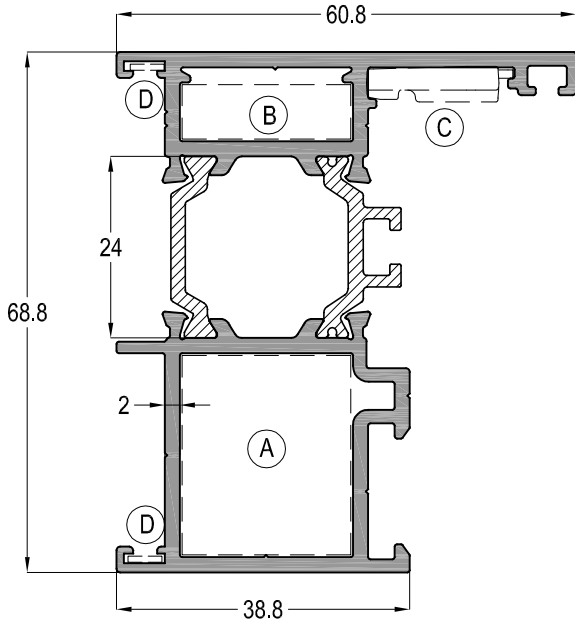

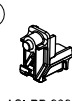
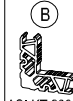
2 mm ET KALINLIĞINDA SİSTEM PROFİLLERİ

2 mm THICKNESS SYSTEM PROFILES

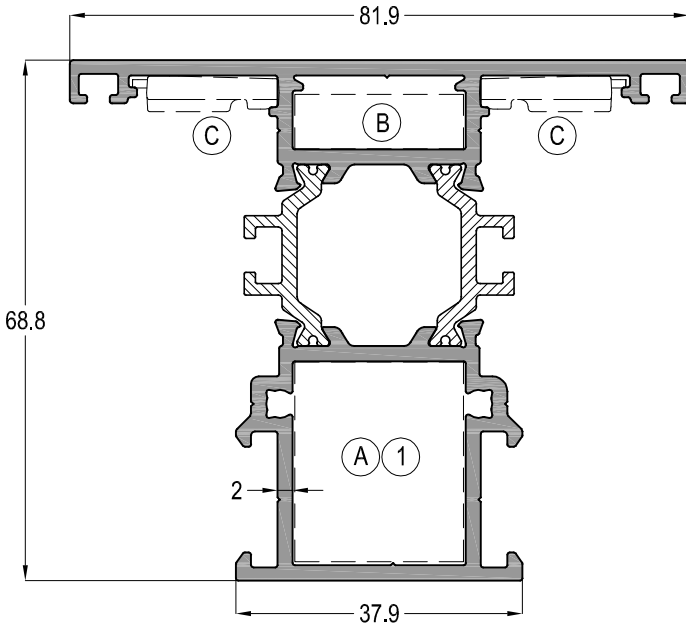

TH68 201				Jx cm ⁴	Jy cm ⁴
				35,28	13,29
				AĞIRLIK / Weight	
ASI-KT 2660-ASI-PB 2326	ASI-KT 2308	ASI-FUJII 2000	ASI-SB 19	1,678 kg/mt	



TH68 222				Jx cm ⁴	Jy cm ⁴
				40,04	20,87
				AĞIRLIK / Weight	
ASI-KT 2660-ASI-PB 2326	ASI-KT 2308	ASI-FUJII 2000	ASI-DB 9123	1,875 kg/mt	

TH68 - 1,8mm

YALITIMLI KAPLI-PENCERE SİSTEMİ
THERMAL WINDOW&DOOR SYSTEM

ASISTAL

2 mm ET KALINLIĞINDA SİSTEM PROFİLLERİ

2 mm THICKNESS SYSTEM PROFILES

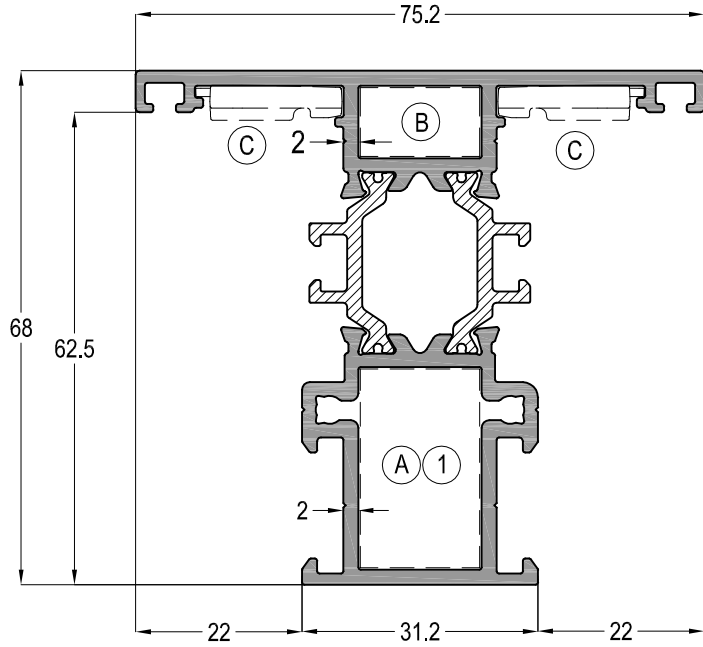

TH68 226				Jx cm ⁴	Jy cm ⁴
				31,80	13,97
(A)	(B)	(C)	(1)	AĞIRLIK / Weight	
ASI-KT 1626	ASI-KT 1609	ASI-FUJII 2000	ASI-DB 9116	1,711 kg/mt	

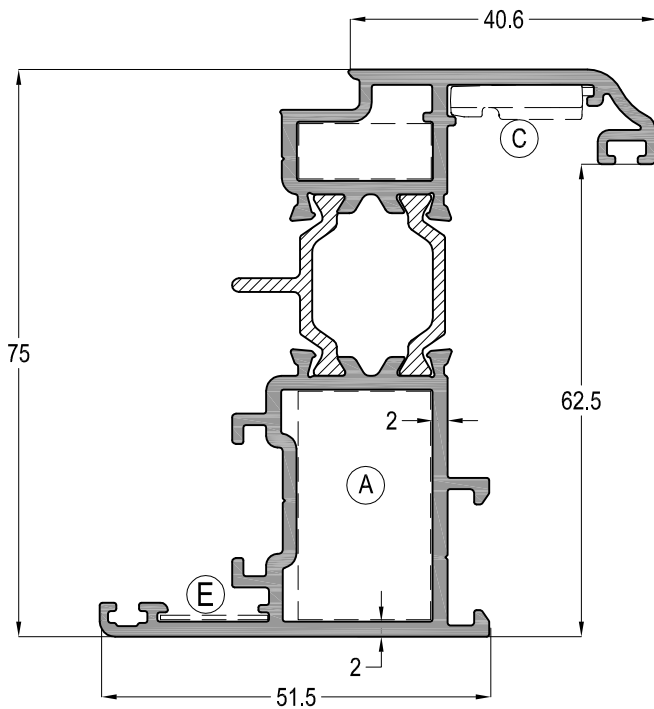

TH68 216				Jx cm ⁴	Jy cm ⁴
				13,25	5,79
(A)	(B)	(C)	(E)	AĞIRLIK / Weight	
ASI-KT 1830	ASI-KT 1807	ASI-FUJII 2000	ASI-SB 19.1	1,719 kg/mt	

TH68 - 1,8mm





YALITIMLI KAPI-PENCERE SİSTEMİ
THERMAL WINDOW&DOOR SYSTEM

ASISTAL

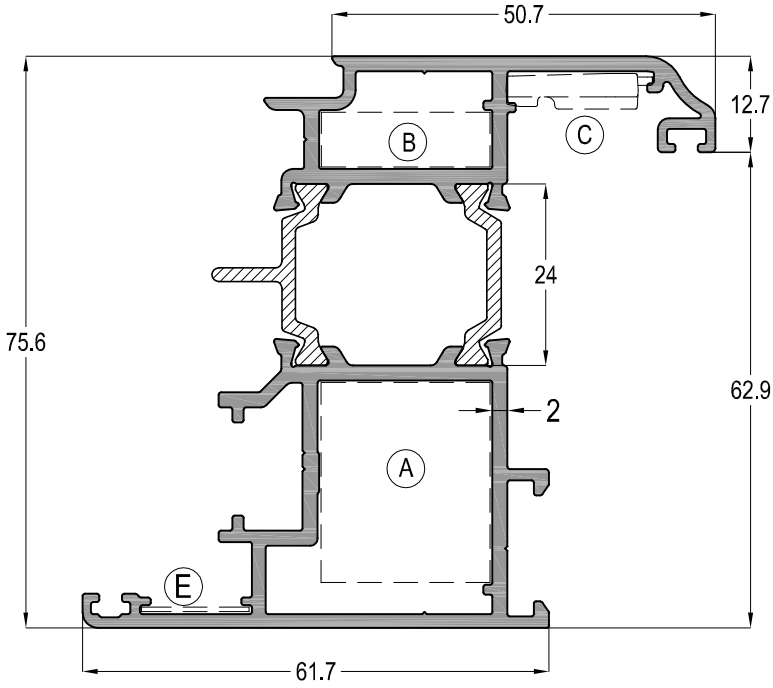



2 mm ET KALINLIĞINDA SİSTEM PROFİLLERİ

2 mm THICKNESS SYSTEM PROFILES

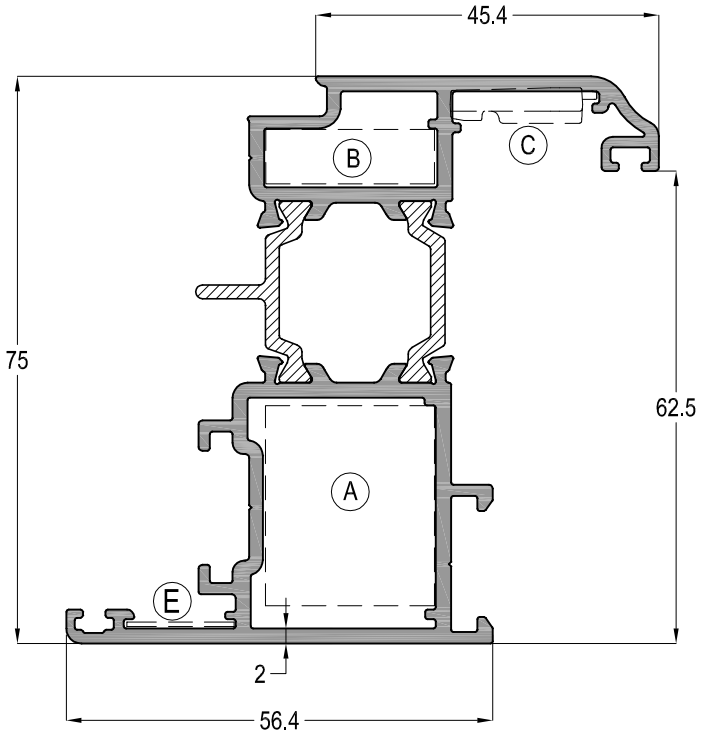

TH68 214				Jx cm ⁴	Jy cm ⁴
				AĞIRLIK / Weight	
ASI-KT 2660-ASI-PB 2326	ASI-KT 2308	ASI-FUJI 2000	ASI-SB 19.1		



TH68 211				Jx cm ⁴	Jy cm ⁴
				AĞIRLIK / Weight	
ASI-KT 2660-ASI-PB 2326	ASI-KT 2308	ASI-FUJI 2000	ASI-SB 19.1		

TH68 - 1,8mm





YALITIMLI KAPI-PENCERE SİSTEMİ
THERMAL WINDOW&DOOR SYSTEM

ASISTAL

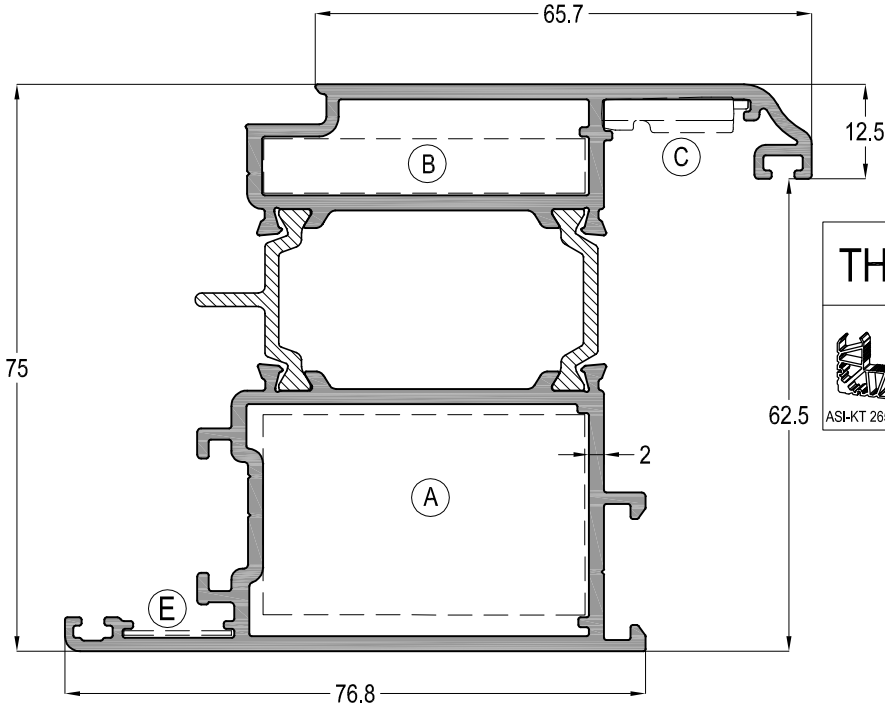



2 mm ET KALINLIĞINDA SİSTEM PROFİLLERİ

2 mm THICKNESS SYSTEM PROFILES

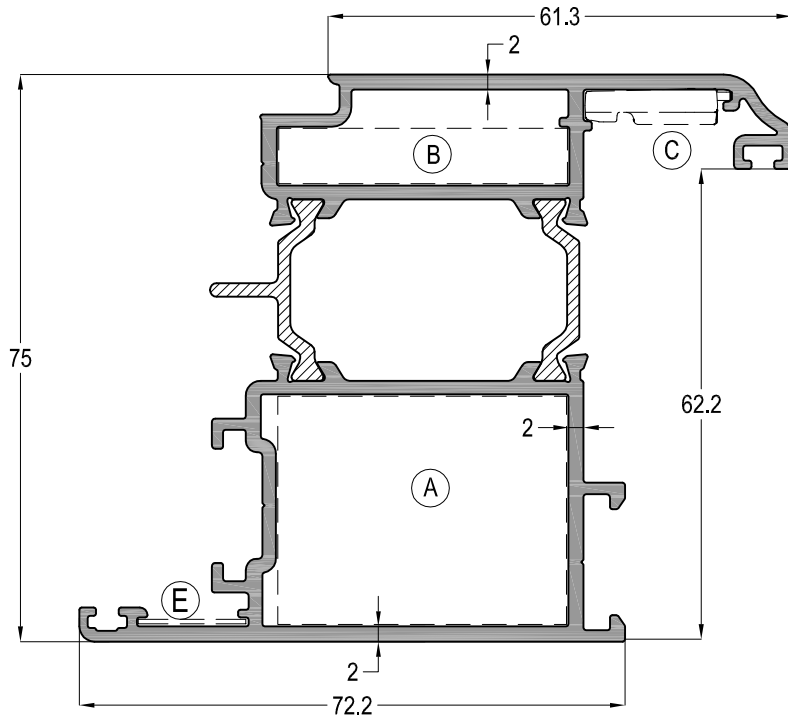





TH68 212				Jx cm ⁴	Jy cm ⁴
				AĞIRLIK / Weight	
ASI-KT 2650-ASI-PB 2650	ASI-KT 4308	ASI-FUJJI 2000	ASI-SB 19.1		

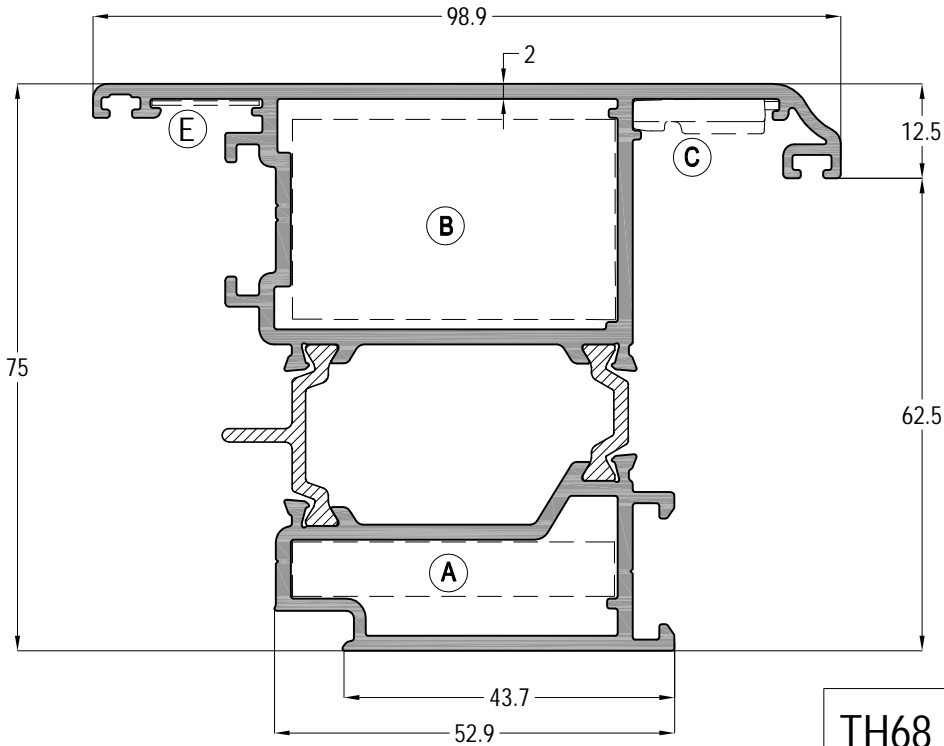

TH68 215				Jx cm ⁴	Jy cm ⁴
				34,13	27,60
ASI-KT 3830	ASI-KT 3807	ASI-FUJJI 2000	ASI-SB 19.1	AĞIRLIK / Weight	
				2,145 kg/mt	

2 mm ET KALINLIĞINDA SİSTEM PROFİLLERİ
2 mm THICKNESS SYSTEM PROFILES

TH68 213

				A IRLIK / Weight
ASI-KT 2650-ASI-PB 2650	ASI-KT 4308	ASI-FUJI 2000	ASI-SB 19.1	2,360 kg/mt

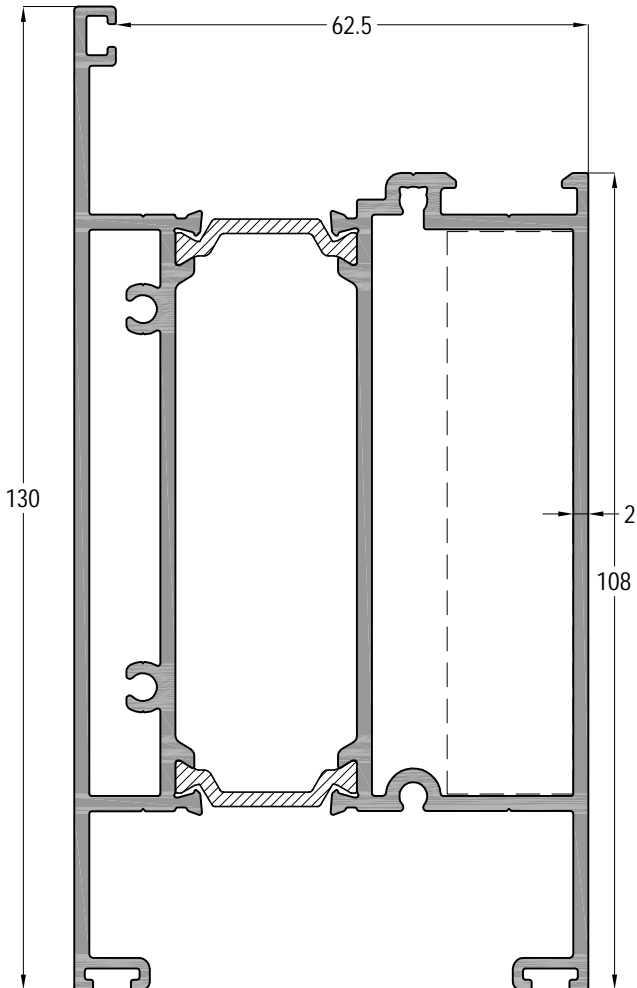

TH68 231

	A IRLIK / Weight
ASI-DB 9174	3,121 kg/mt

TH68 - 1,8mm

YALITIMLI KAPI-PENCERE SİSTEMİ
THERMAL WINDOW&DOOR SYSTEM

ASISTAL

2 mm ET KALINLIĞINDA SİSTEM PROFİLLERİ
2 mm THICKNESS SYSTEM PROFILES

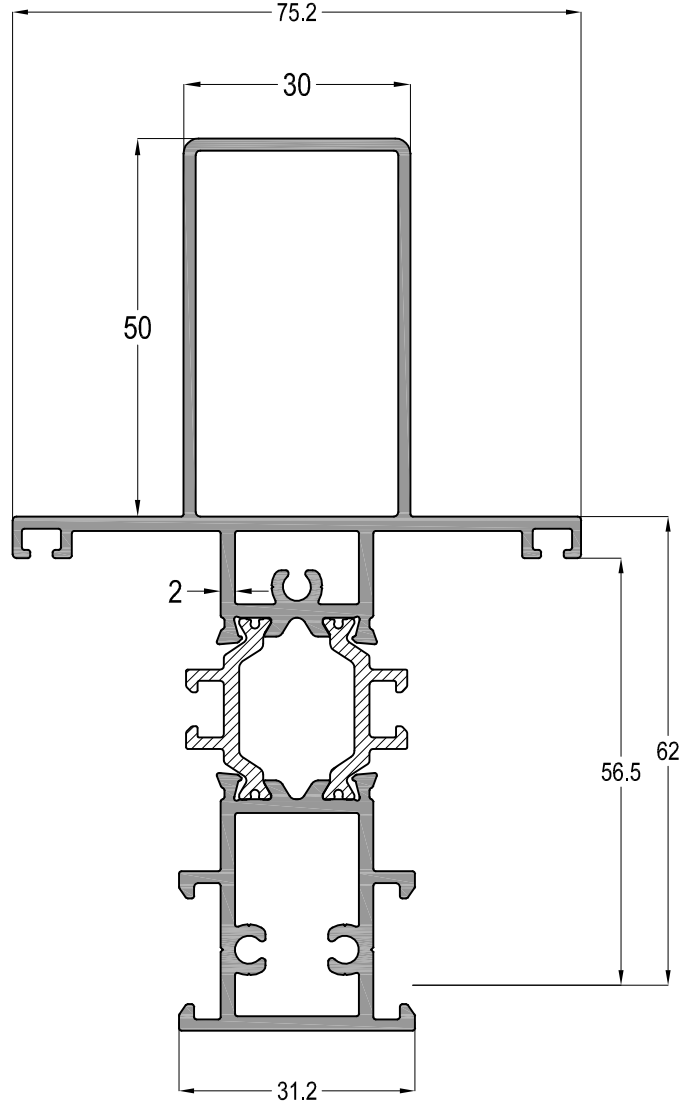

TH68 225	Jx cm ⁴	Jy cm ⁴
	94,09	16,52
	AĞIRLIK / Weight	
	2,256 kg/mt	

TH68 - 1,8mm



YALITIMLI KAPI-PENCERE SİSTEMİ
THERMAL WINDOW&DOOR SYSTEM

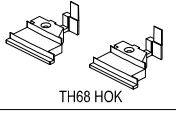

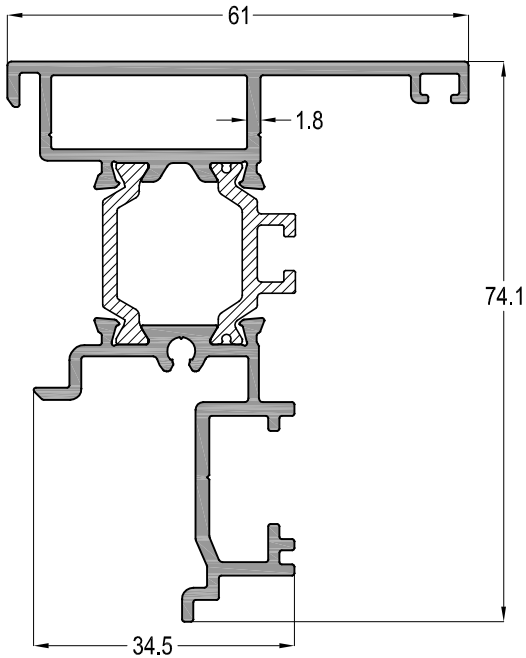
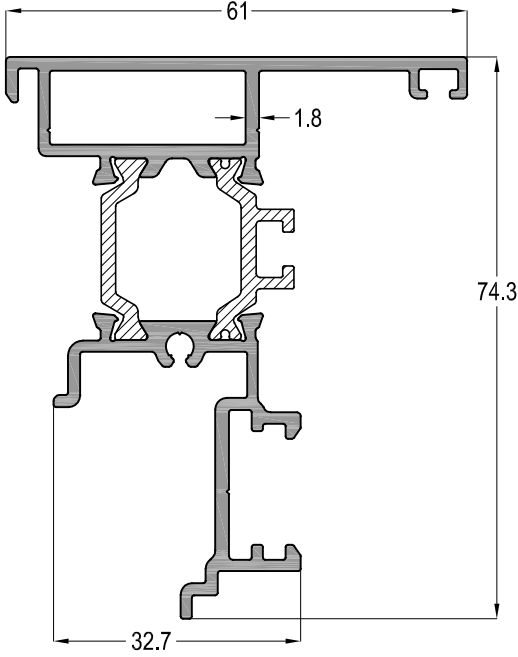
TH68 41	
 TH68 HOK	AĞIRLIK / Weight 1,346 kg/mt



TH68 42	
 TH68 HOK	AĞIRLIK / Weight 1,367 kg/mt

TH68 43			
 A ASI-KT 2319	 B ASI-KT 2308	 C ASI-FUJI 2000	AĞIRLIK / Weight 1,429 kg/mt

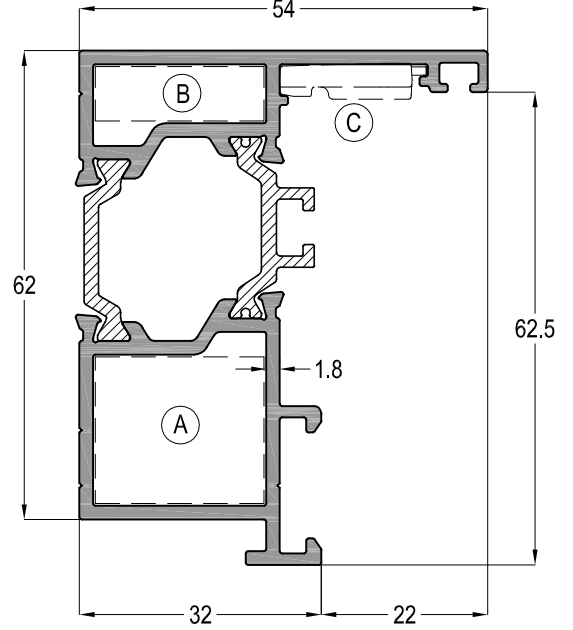

TH68 - THS68

YALITIMLI KAPI-PENCERE SİSTEMİ
THERMAL WINDOW&DOOR SYSTEM

ASISTAL

TH68 52	Jx cm ⁴	Jy cm ⁴
	29,52	30,21
	AĞIRLIK / Weight	
	1,707 kg/mt	

TH68 31	Jx cm ⁴	Jy cm ⁴
	131,71	65,85
 ASI-DB 9174	AĞIRLIK / Weight	
	2,862 kg/mt	

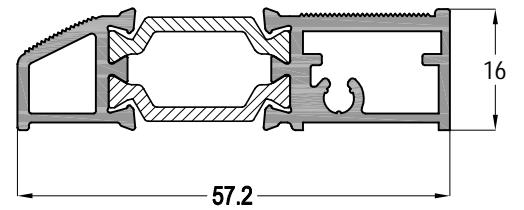
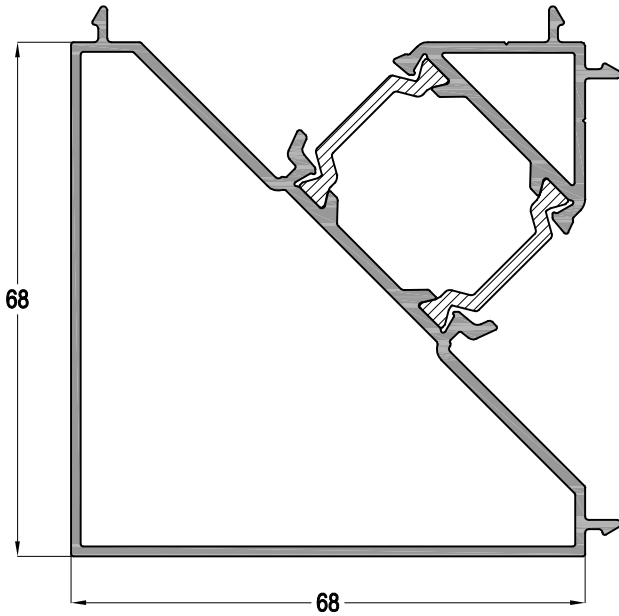
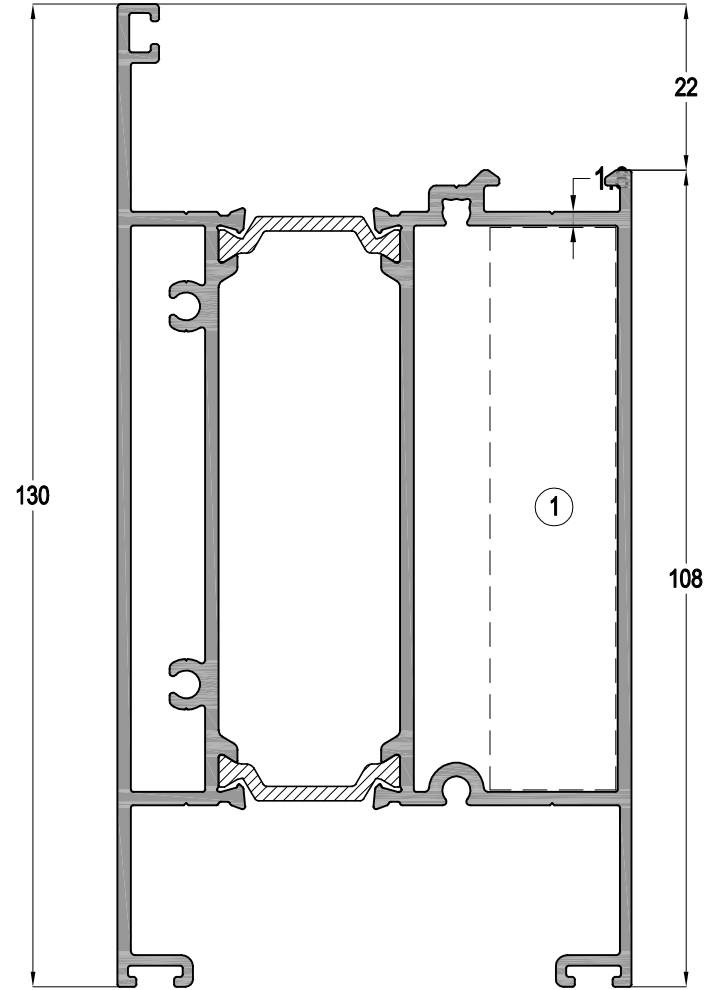
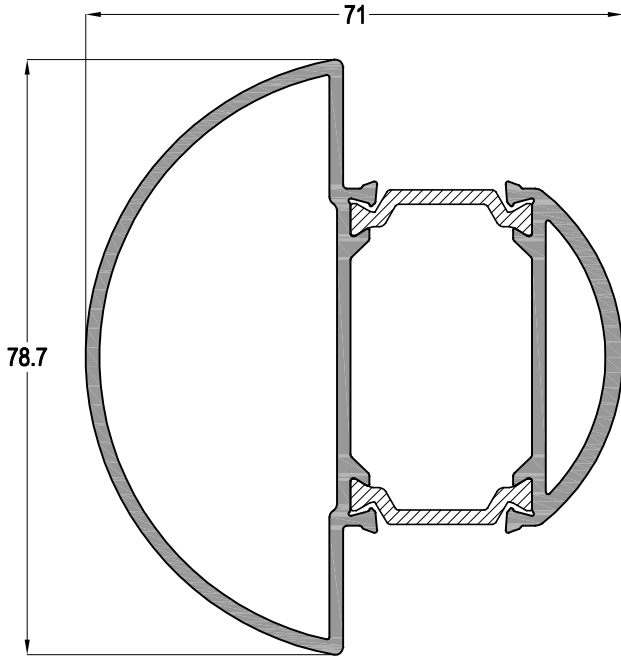

TH68 53	Jx cm ⁴	Jy cm ⁴
	30,95	34,82
	AĞIRLIK / Weight	
	1,562 kg/mt	

12-37	AĞIRLIK / Weight	
	0,821 kg/mt	

TH68 - 1,8mm

YALITIMLI KAPI-PENCERE SİSTEMİ
THERMAL WINDOW&DOOR SYSTEM

ASISTAL

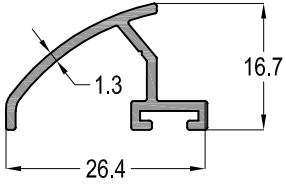

12-01

0,198 kg/mt

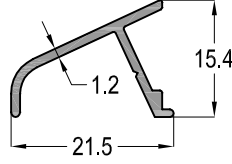

12-02

0,136 kg/mt

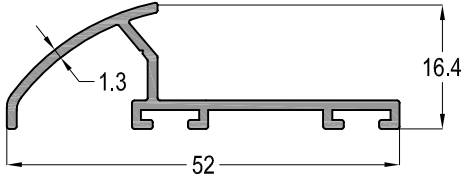

12-03

0,313 kg/mt

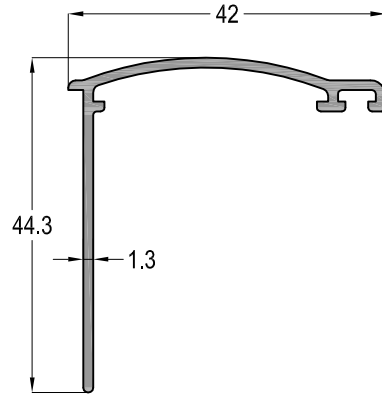

12-54

0,326 kg/mt

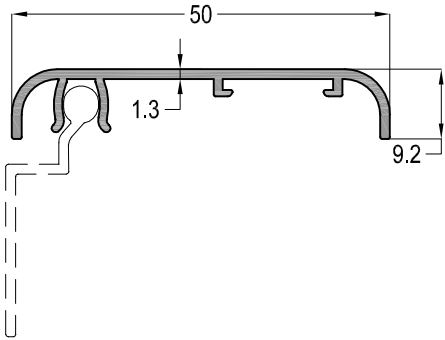

12-52

0,279 kg/mt

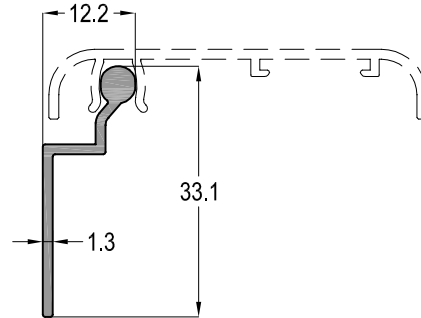

12-53

0,177 kg/mt

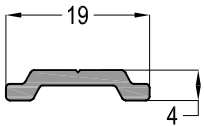

12-41

0,118 kg/mt

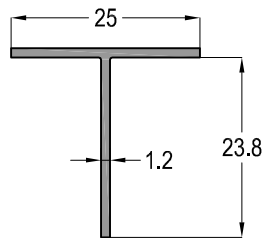

04-025025-12

0,158 kg/mt

TH68 - 1,8mm

YALITIMLI KAPLI-PENCERE SİSTEMİ
THERMAL WINDOW&DOOR SYSTEM

ASISTAL

11-006

0,218 kg/mt

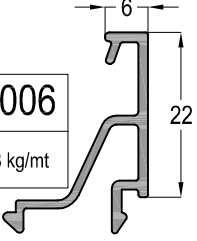

11-004

0,181 kg/mt

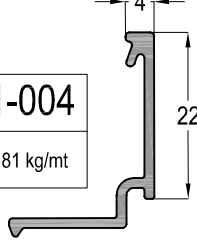

11-010

0,233 kg/mt

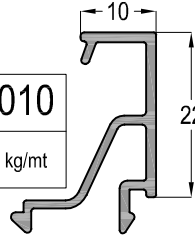

11-015

0,241 kg/mt

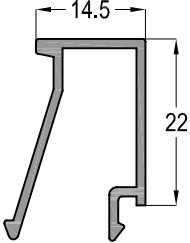

11-017

0,250 kg/mt

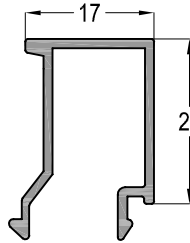

11-020

0,276 kg/mt

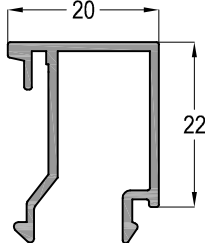

11-022

0,282 kg/mt

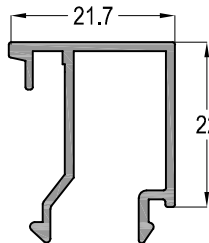

11-026

0,296 kg/mt

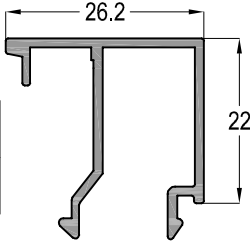

11-028

0,302 kg/mt

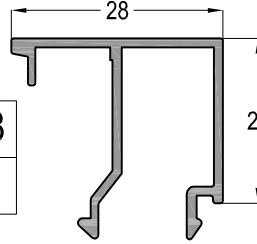

11-030

0,308 kg/mt

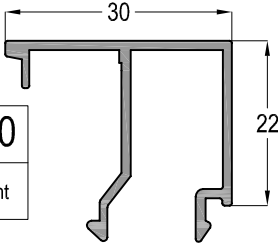

11-032

0,315 kg/mt

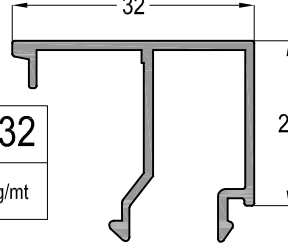

11-035

0,323 kg/mt

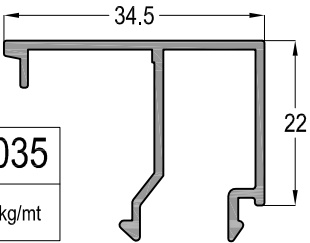

11-038

0,334 kg/mt

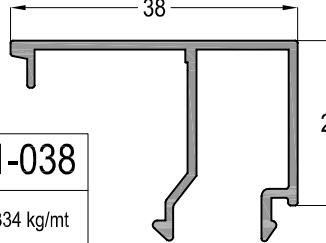

11-044

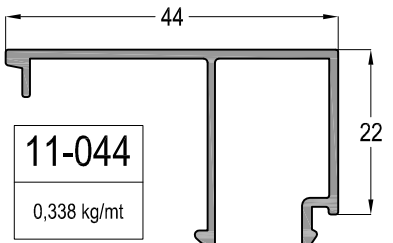

0,338 kg/mt



CAM KALINLIĞINA GÖRE CAM ÇITASI SEÇİM TABLOSU
Glazing Bead Selection Table according to the Glass
Thickness

CAM KALINLIĞI Glass Thickness (mm)	CAM ÇITASI Glazing Bead	İÇ CAM FİTİLİ Glass Gasket (IN)	DIŞ CAM FİTİLİ Glass Gasket (OUT)
10	11-044	EP2-03	EP1-01
11	11-044	EP2-02	EP1-01
12	11-044	EP2-01	EP1-01
16	11-038	EP2-03	EP1-01
17	11-038	EP2-02	EP1-01
18	11-038	EP2-01	EP1-01
19	11-035	EP2-03	EP1-01
20	11-035	EP2-02	EP1-01
21	11-035	EP2-01	EP1-01
22	11-032	EP2-03	EP1-01
23	11-032	EP2-02	EP1-01
24	11-032	EP2-01	EP1-01
25	11-030	EP2-02	EP1-01
26	11-028	EP2-03	EP1-01
27	11-028	EP2-02	EP1-01
28	11-028	EP2-01	EP1-01
29	11-026	EP2-02	EP1-01
30	11-026	EP2-01	EP1-01
32	11-022	EP2-03	EP1-01
33	11-022	EP2-02	EP1-01
34	11-022	EP2-01	EP1-01
35	11-020	EP2-02	EP1-01
36	11-020	EP2-01	EP1-01
37	11-017	EP2-03	EP1-01
38	11-017	EP2-02	EP1-01
39	11-017	EP2-01	EP1-01
40	11-015	EP2-02	EP1-01
41	11-015	EP2-01	EP1-01
42	11-010	EP2-03	EP1-01
45	11-010	EP2-02	EP1-01
46	11-010	EP2-01	EP1-01
48	11-006	EP2-03	EP1-01
49	11-006	EP2-02	EP1-01
50	11-006	EP2-01	EP1-01
51	11-004	EP2-03	EP1-01
52	11-004	EP2-02	EP1-01

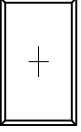
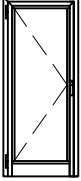
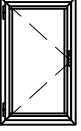
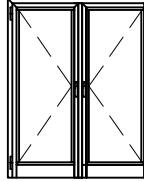
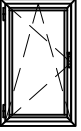
AÇILIM TİPLERİ - OPENING TYPES

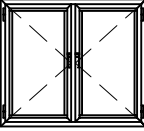
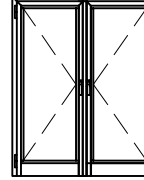
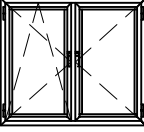
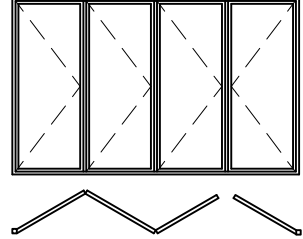
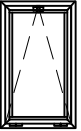
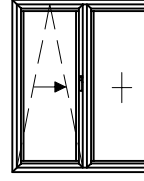
 <p>SABİT FIXED</p>	 <p>TEK KANAT İÇE AÇILIR KAPI SINGLE INNER OPENING DOOR</p>
 <p>TEK AÇILIR KANAT SINGLE OPENING SASH</p>	 <p>ÇİFT KANAT İÇE AÇILIR KAPI DOUBLE INNER OPENING DOOR</p>
 <p>TEK KANAT ÇİFT EKSEN AÇILIM KANAT SINGLE TILT-TURN OPENING SASH</p>	 <p>TEK KANAT DIŞA AÇILIR KAPI SINGLE OUTER OPENING DOOR</p>
 <p>ÇİFT AÇILIR KANAT DOUBLE OPENING SASH</p>	 <p>ÇİFT KANAT DIŞA AÇILIR KAPI DOUBLE OUTER OPENING DOOR</p>
 <p>ÇİFT EKSEN AÇILIM KANAT DOUBLE TILT-TURN OPENING SASH</p>	 <p>KATLANIR KAPI FOLDING DOOR</p>
 <p>VASİSTAS AÇILIR KANAT VENT OPENING SASH</p>	 <p>PARALEL SÜRME KAPI PARALLEL SLIDING OPENING DOOR</p>

TH68 - 1,8mm

YALITIMLI KAPI-PENCERE SİSTEMİ
THERMAL WINDOW&DOOR SYSTEM

ASISTAL

THS SİSTEM DETAYLARI
THS SYSTEM DETAILS

PENCERE AÇILIM DETAYLARI
WINDOW OPENING DETAILS

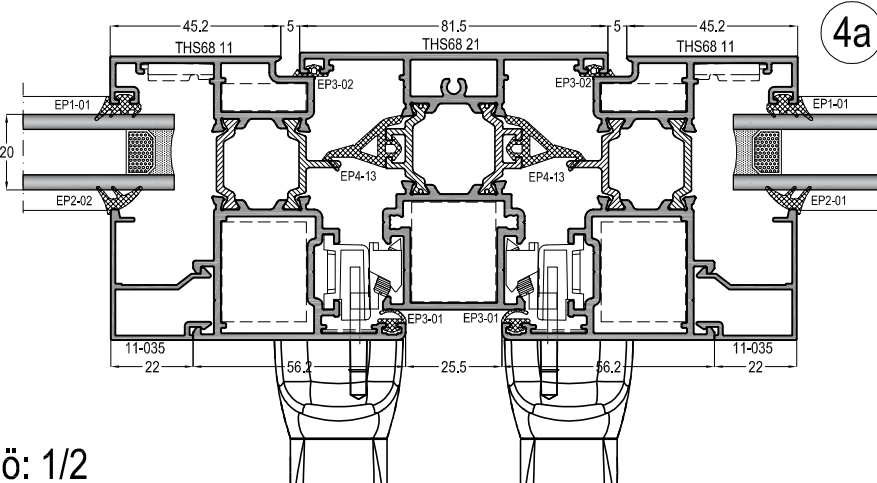
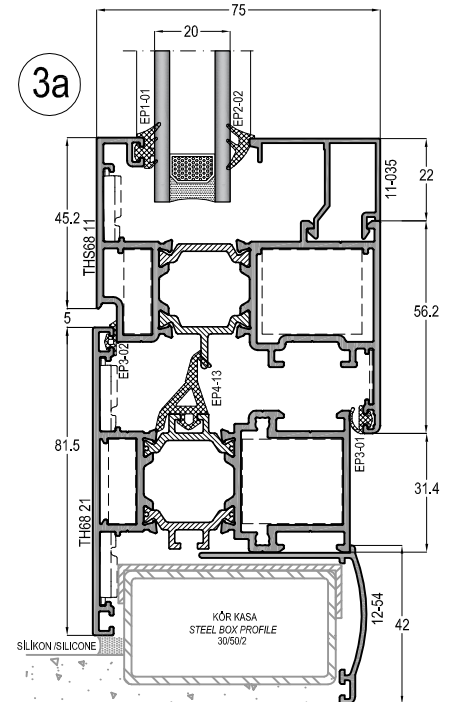
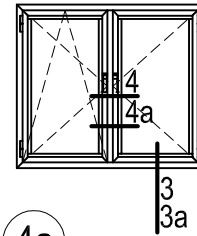
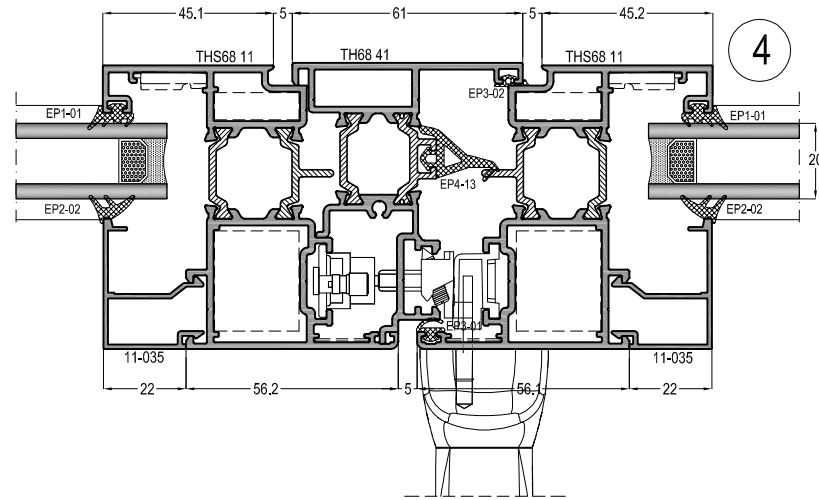
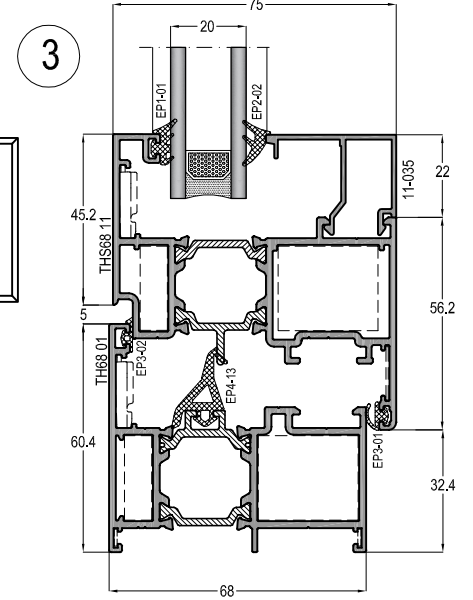
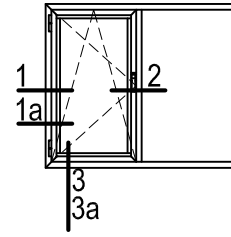
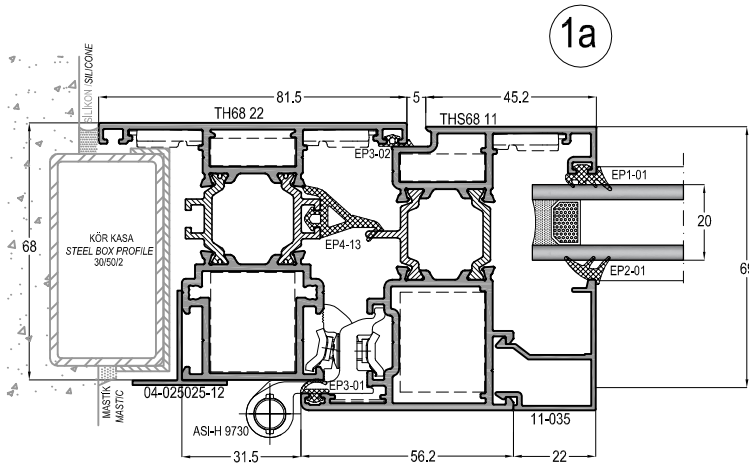
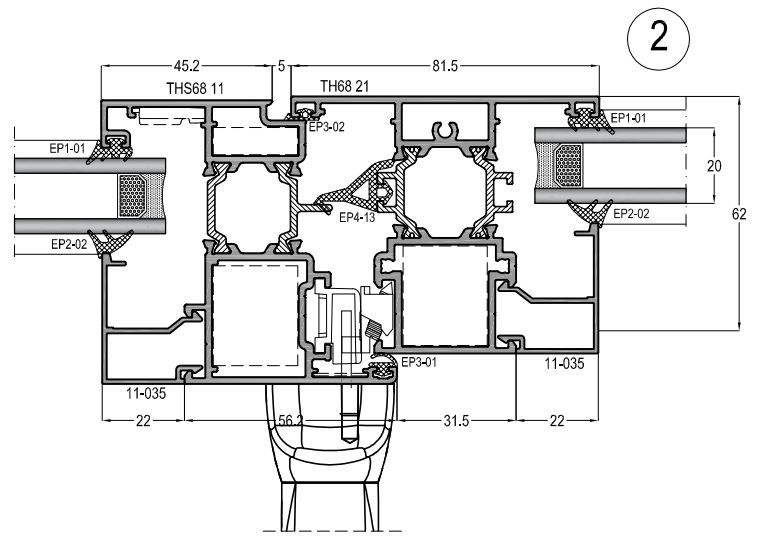
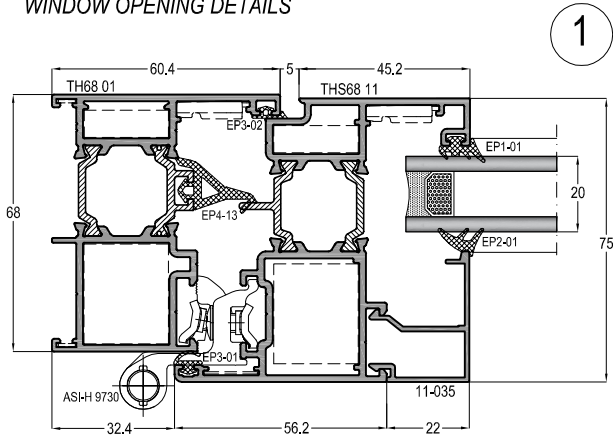

İÇE AÇILIR KAPI DETAYLARI INNER OPENING DOOR DETAILS

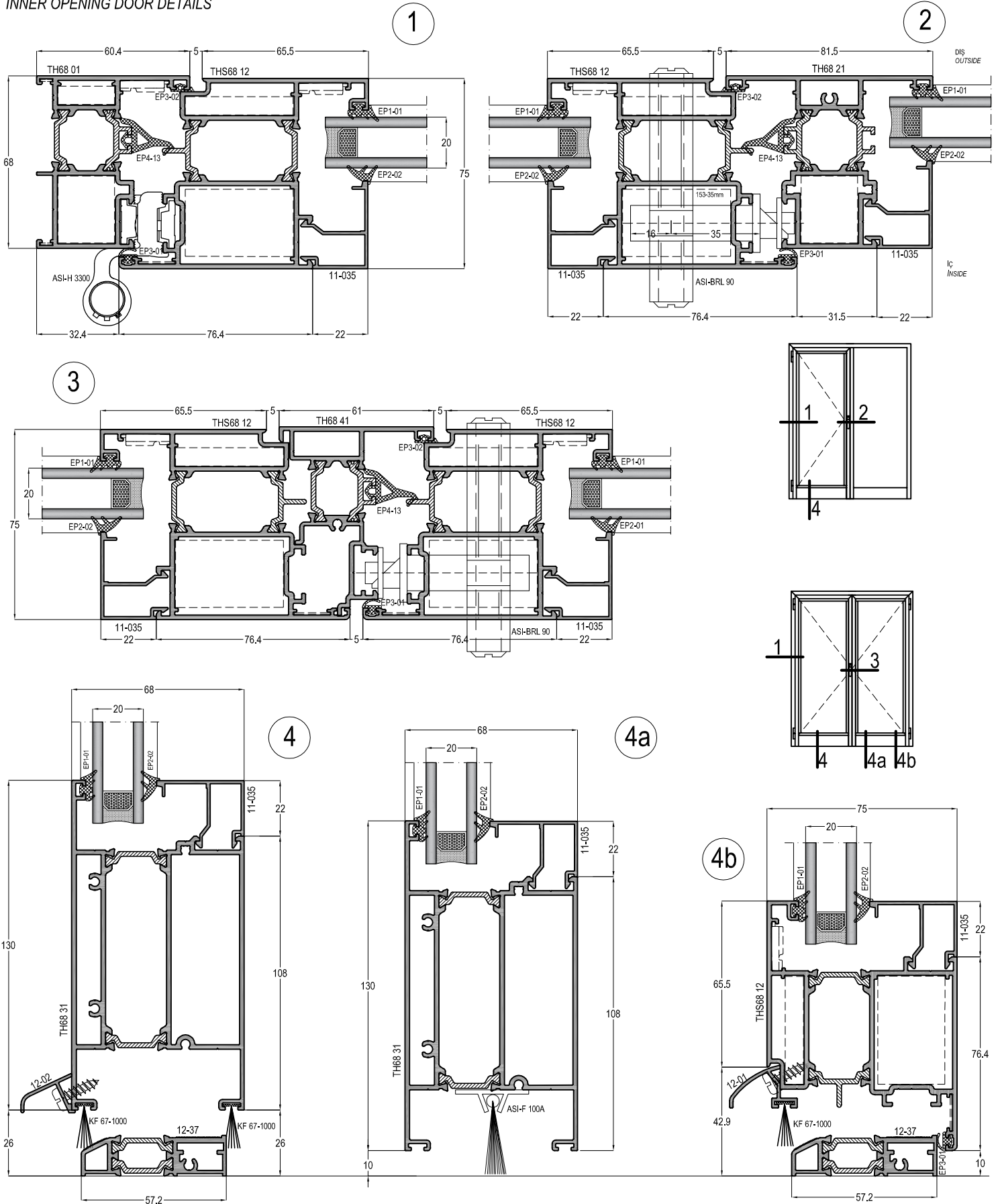

DIŞA AÇILIR KAPI DETAYLARI
OUTER OPENING DOOR DETAILS

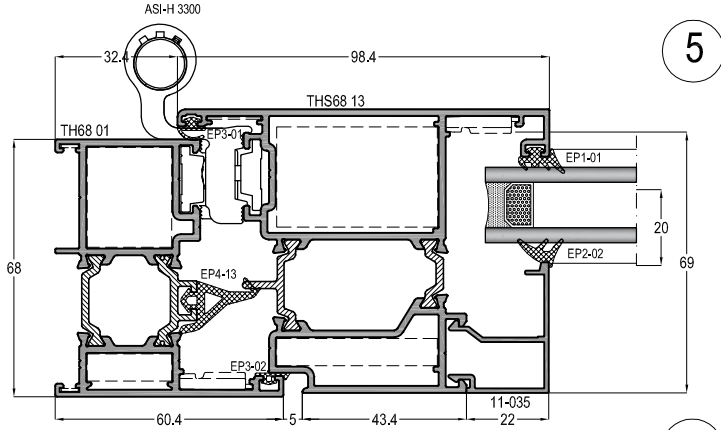

5

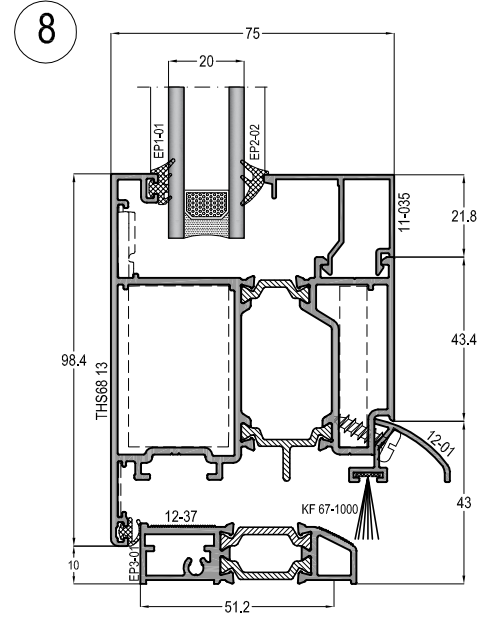

8

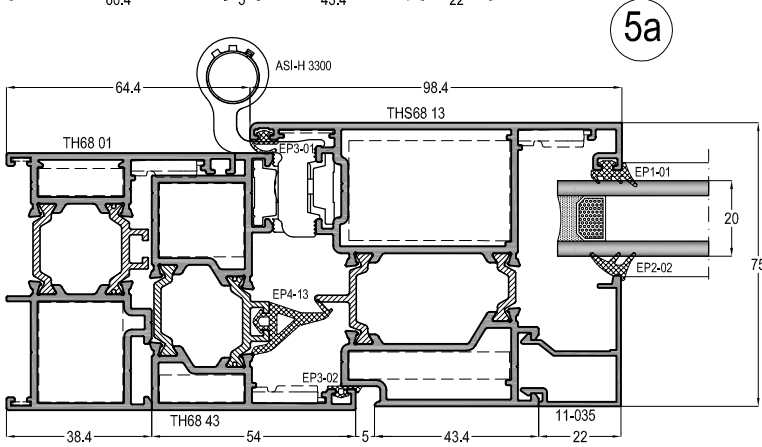

5a

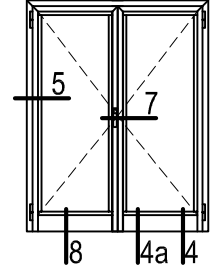
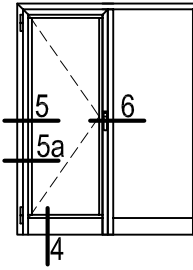

6

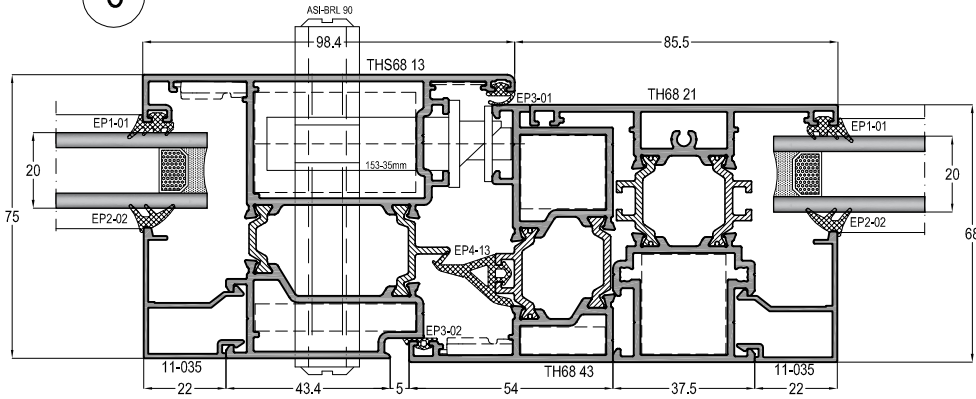

7

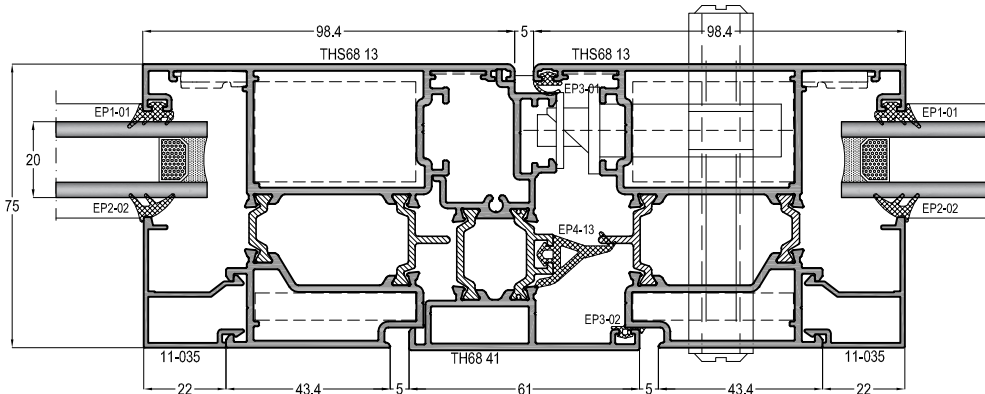

4

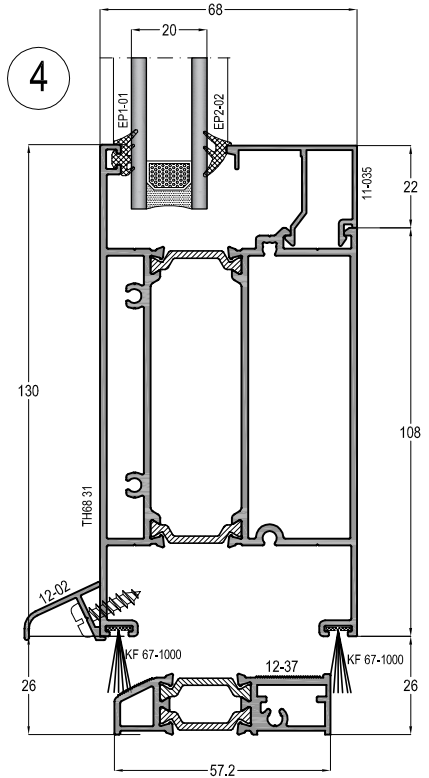

TH68 - 1,8mm

YALITIMLI KAPI-PENCERE SİSTEMİ
THERMAL WINDOW&DOOR SYSTEM



KATLANIR KAPI DETAYLARI FOLDING DOOR DETAILS

1

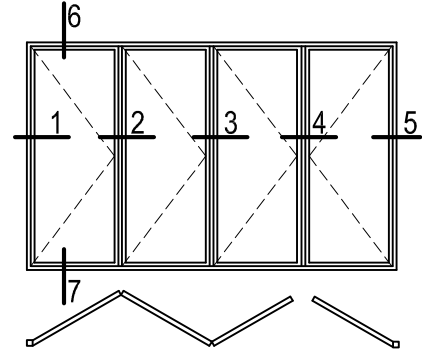
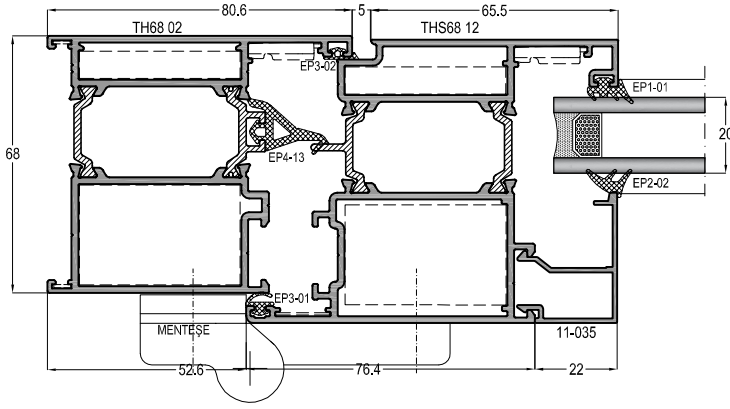

2

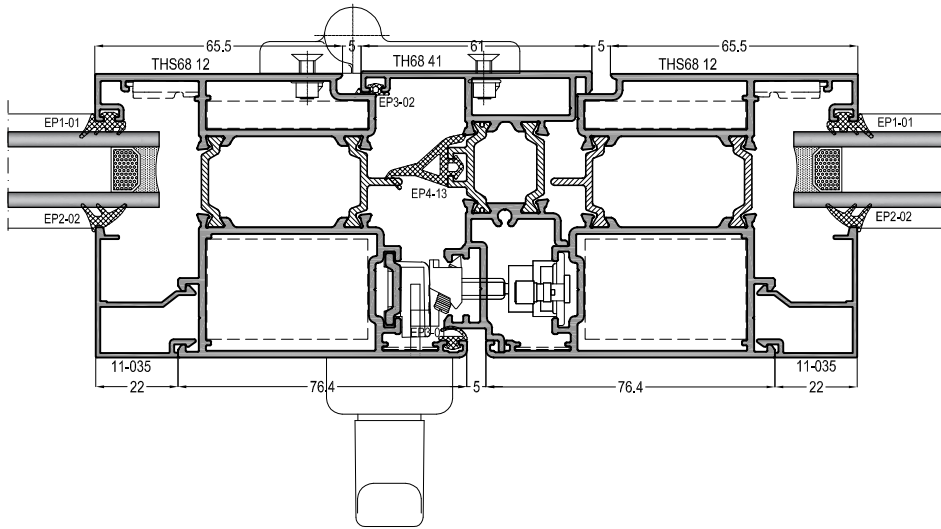

3

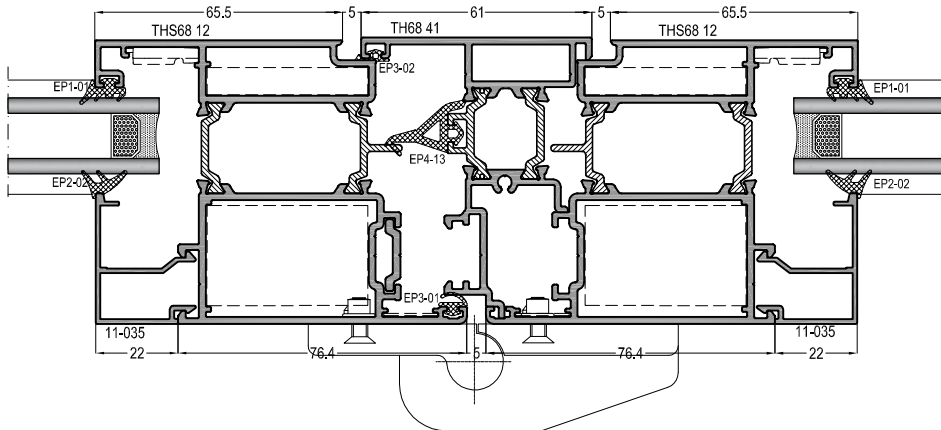

TH68 - 1,8mm

YALITIMLI KAPI-PENCERE SİSTEMİ
THERMAL WINDOW&DOOR SYSTEM

ASISTAL

KATLANIR KAPI DETAYLARI FOLDING DOOR DETAILS

4

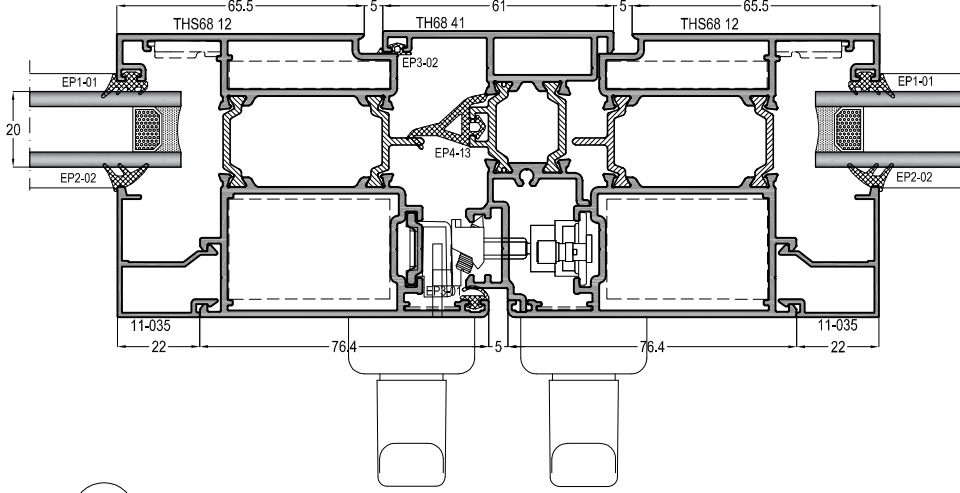

5

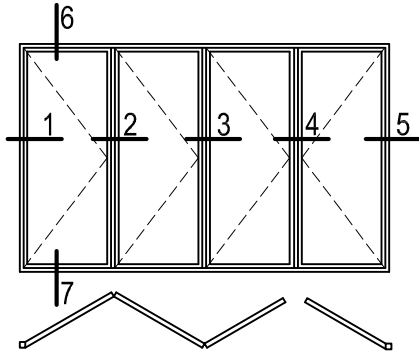
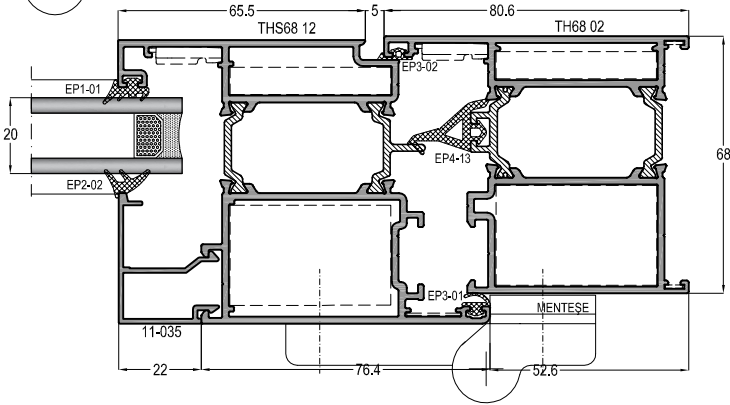

6

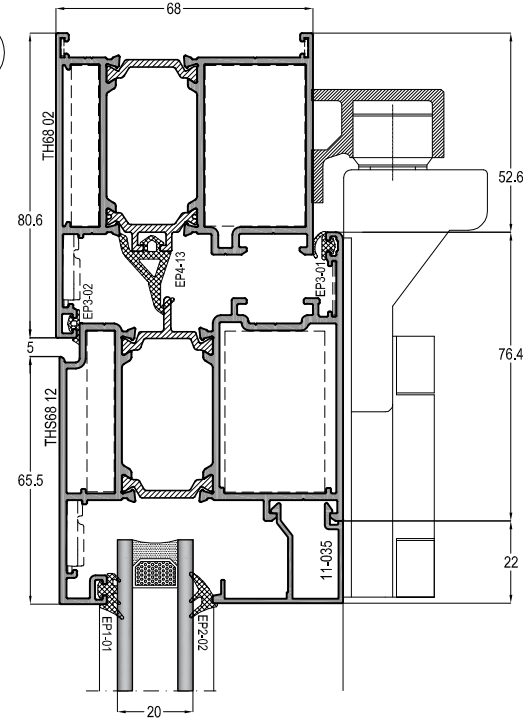

7

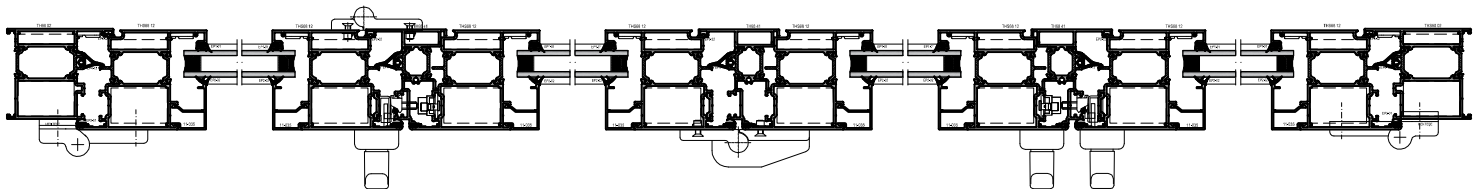
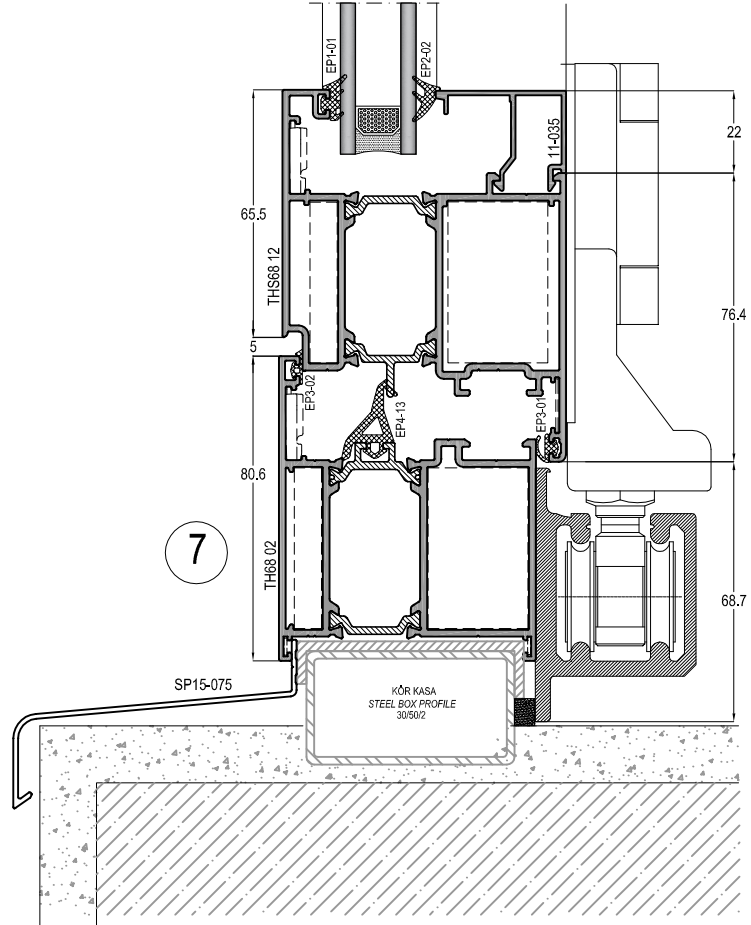

ö: 1/2

Profil ağırlıklarımız teorik olup; teslim anındaki tartımız geçerlidir.

PARALEL SÜRME DETAYLARI
PARALLE SLIDING DETAILS

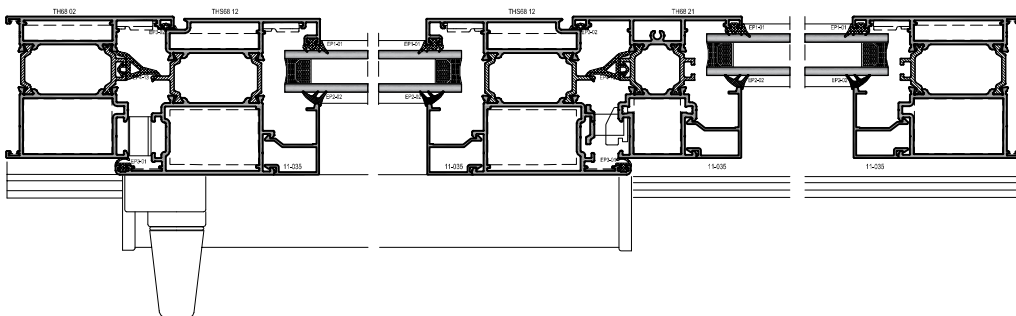
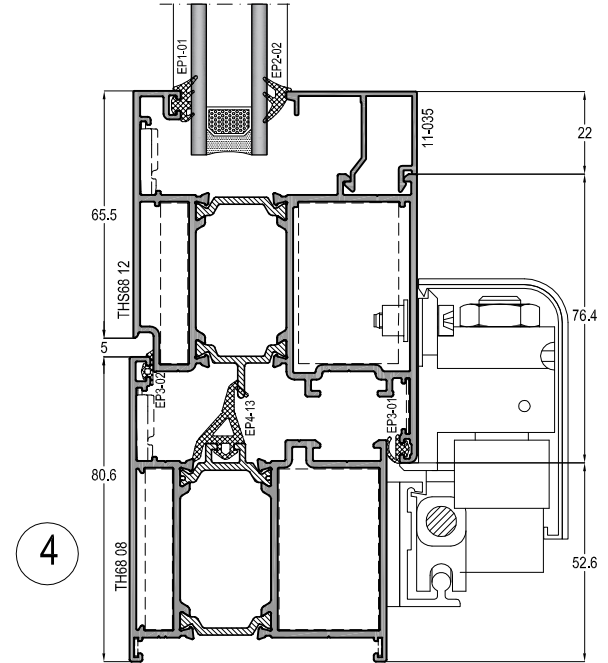
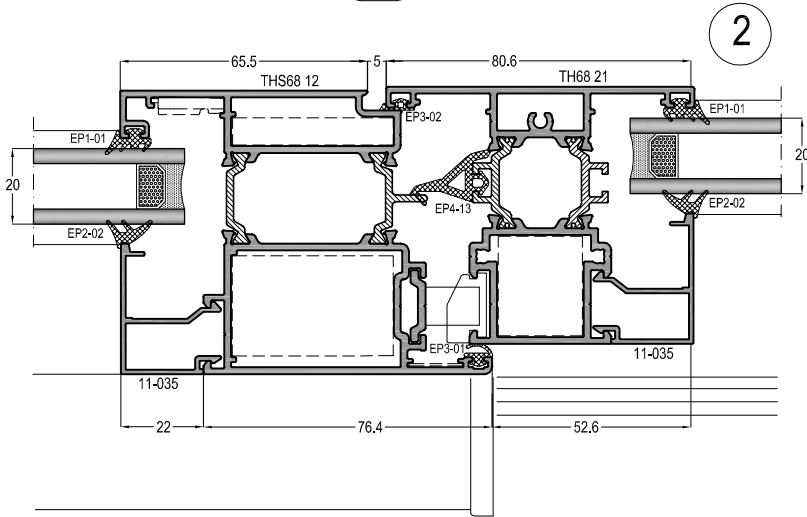
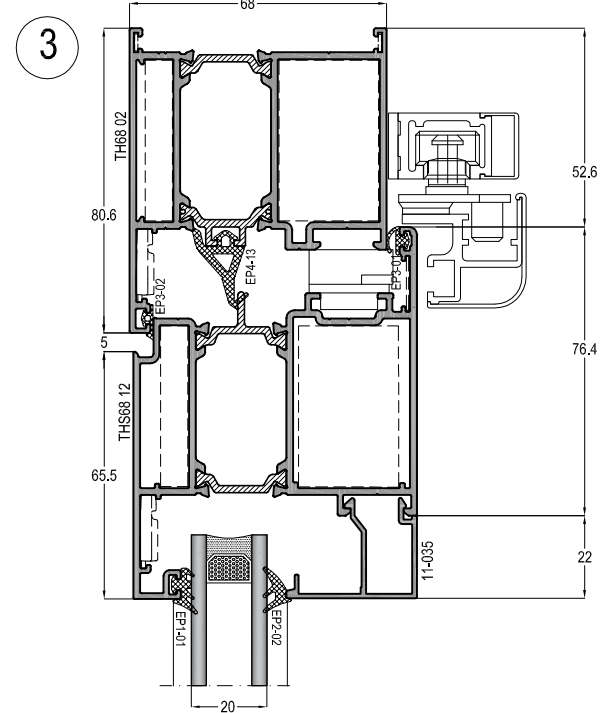
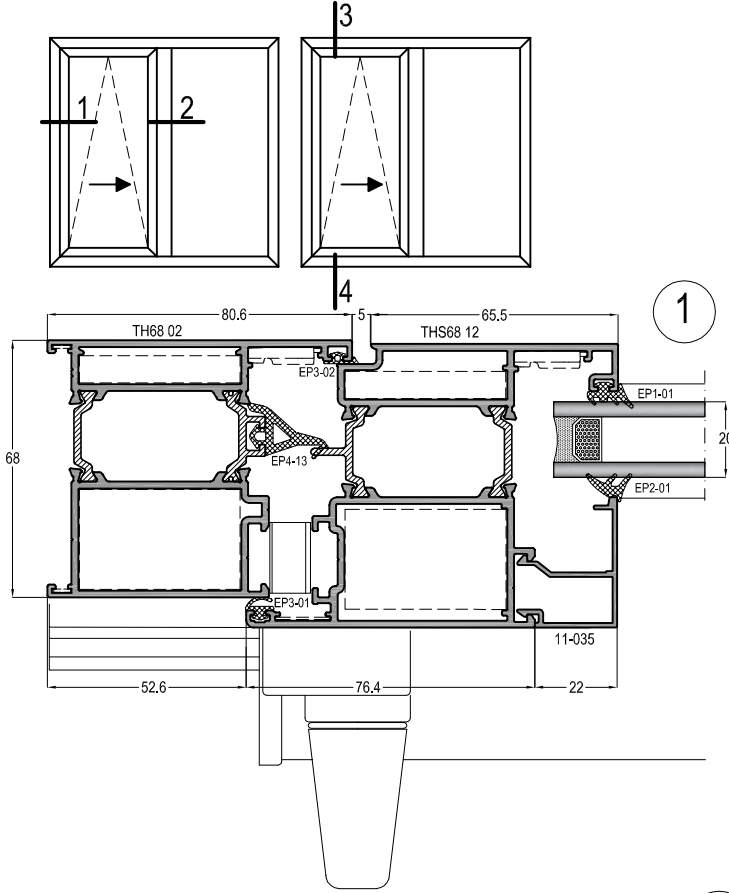

TH68 - 1,8mm

YALITIMLI KAPI-PENCERE SİSTEMİ
THERMAL WINDOW&DOOR SYSTEM

ASISTAL

ÇOK NOKTADAN KİLİTLEME THS SİSTEM DETAYLARI
MULTI POINT LOCKING THS SYSTEM DETAILS

PENCERE AÇILIM DETAYLARI
WINDOW OPENING DETAILS

1

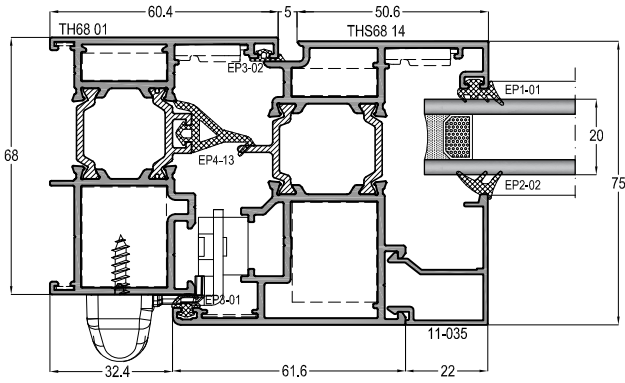

2

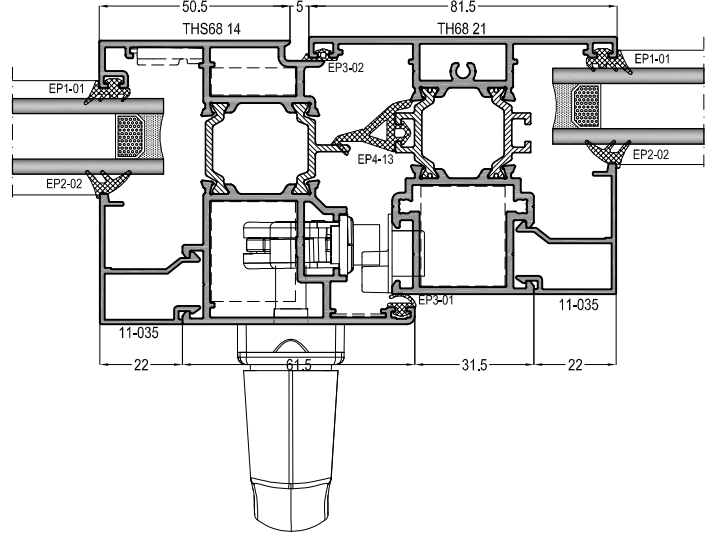

1a

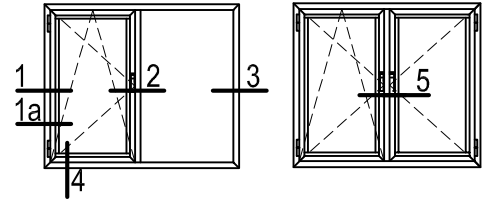
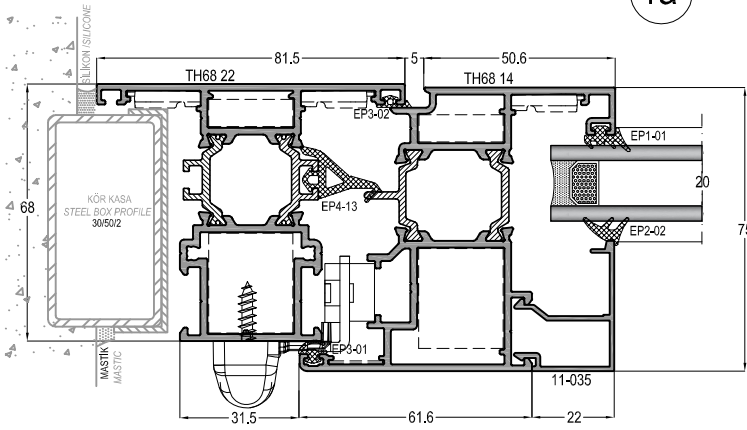

4

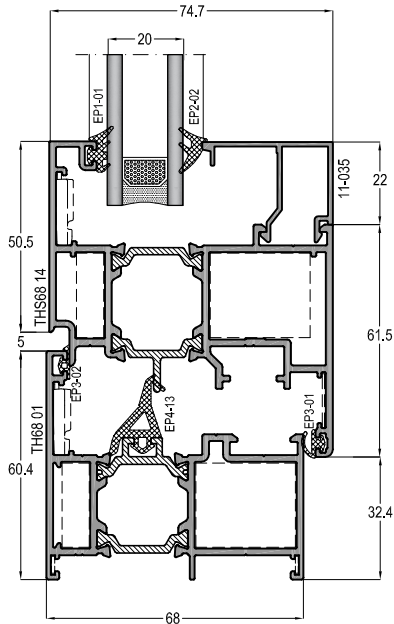

5

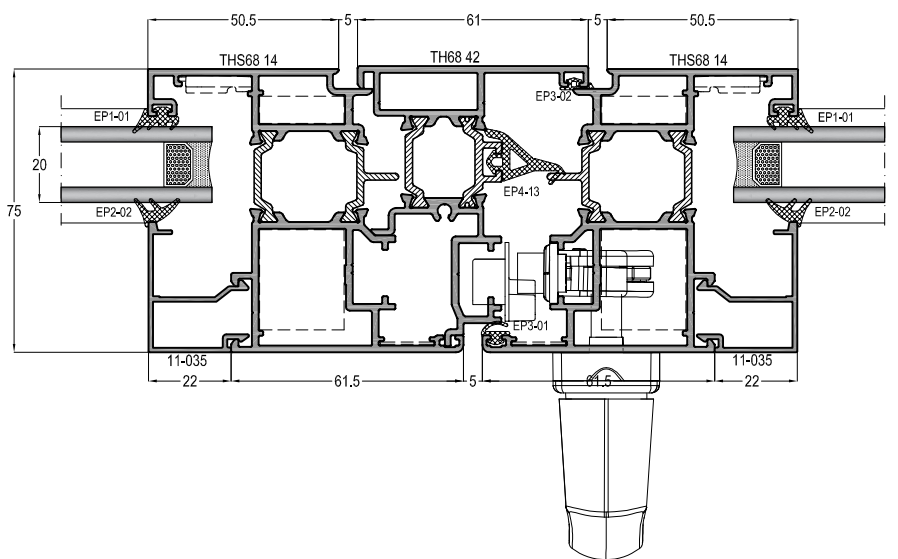

İÇE AÇILIR KAPI DETAYLARI
INNER OPENING DOOR DETAILS

1

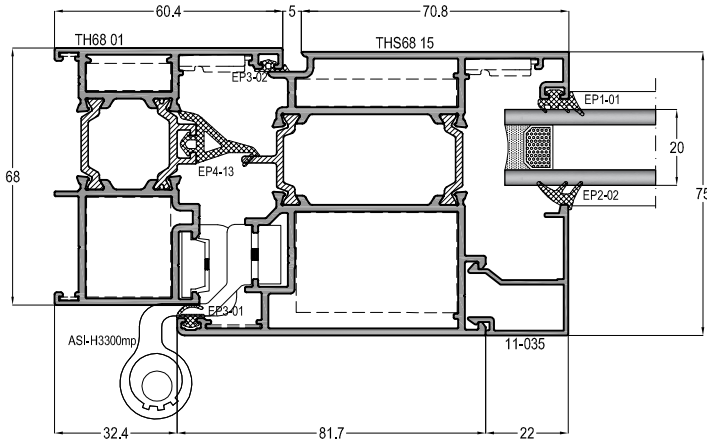

2

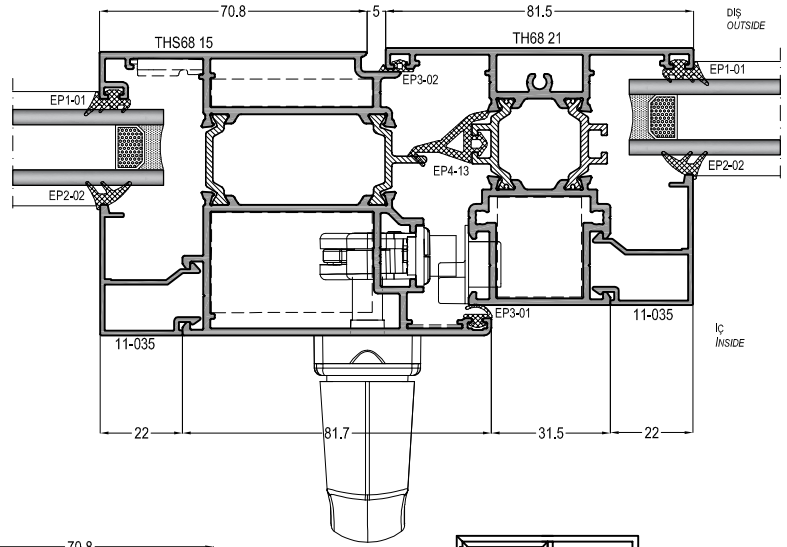

3

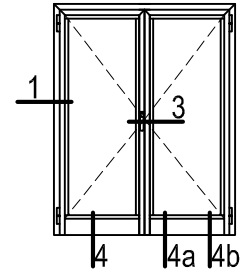
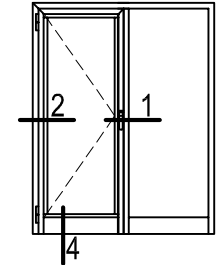
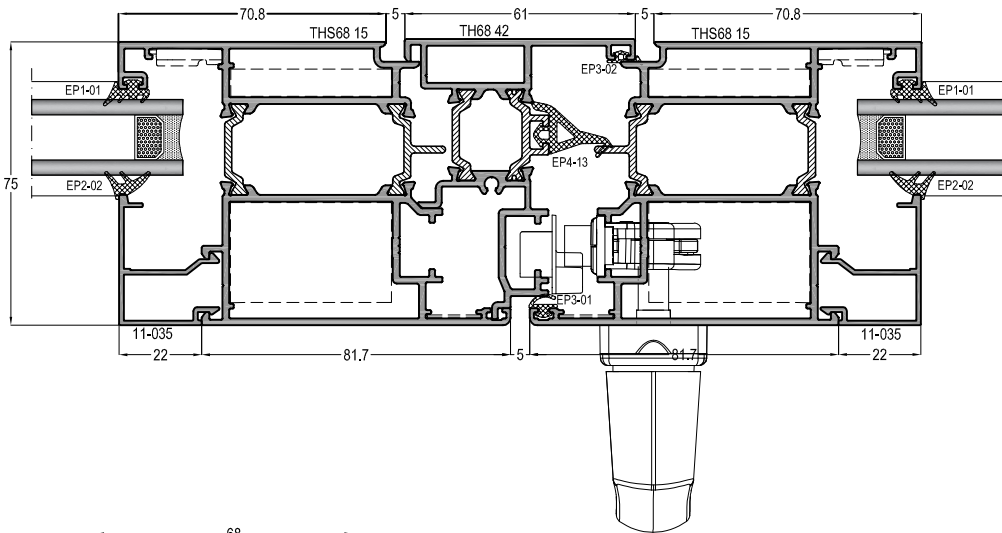

4

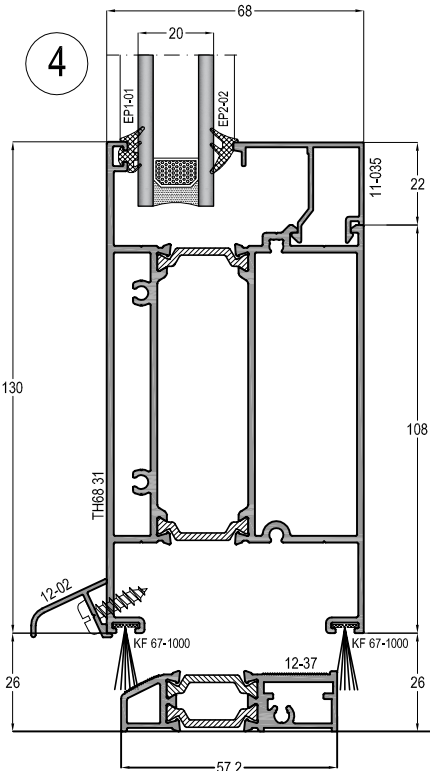

4a

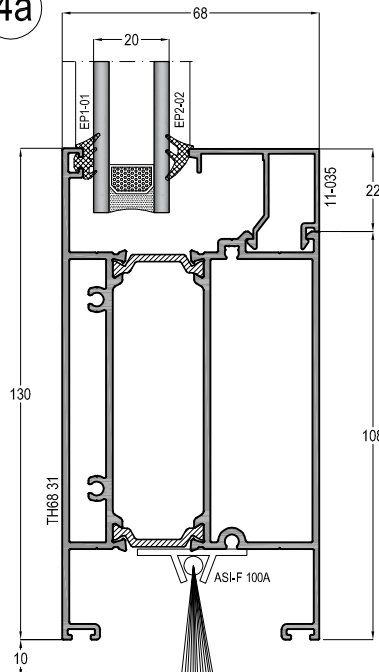

4b

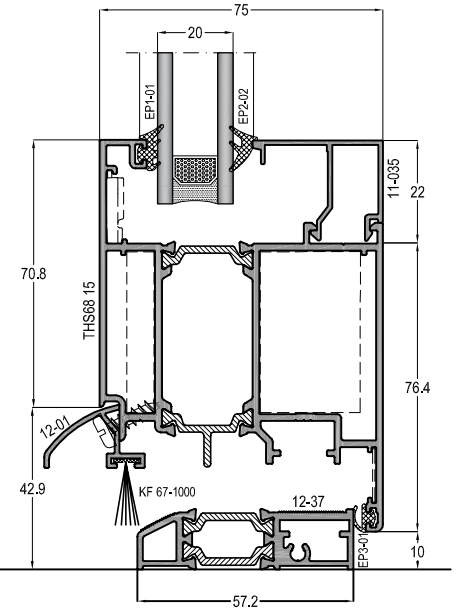

DIŞA AÇILIR KAPI DETAYLARI
OUTER OPENING DOOR DETAILS

5

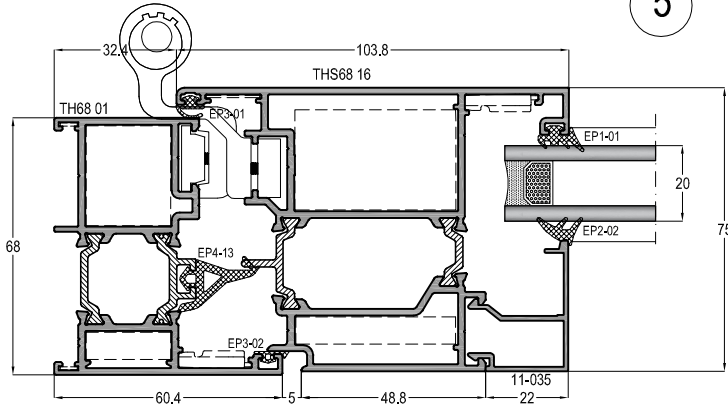

8

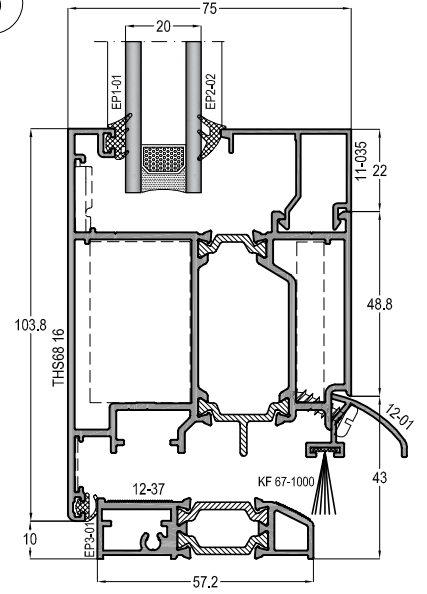

5a

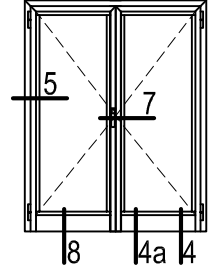
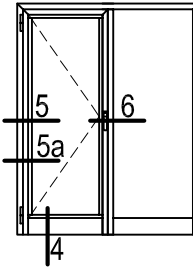
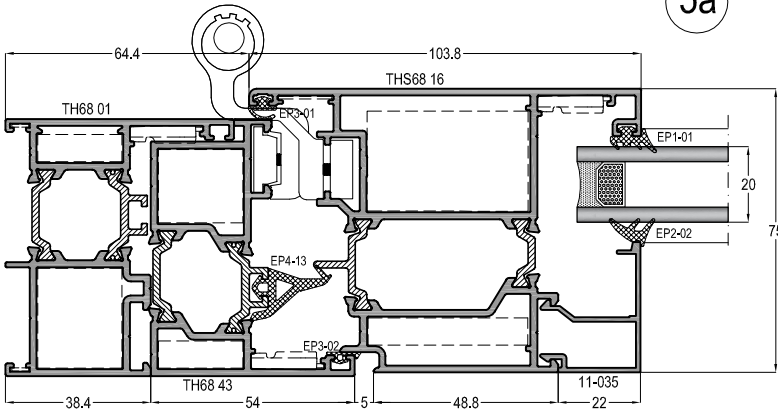

6

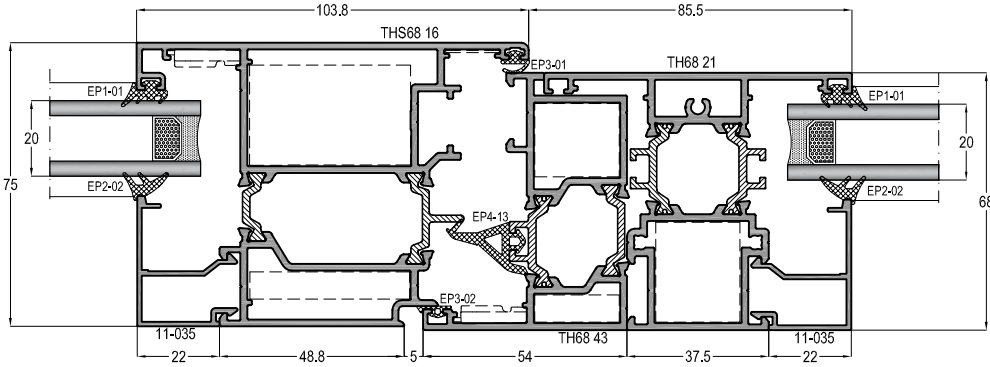

4

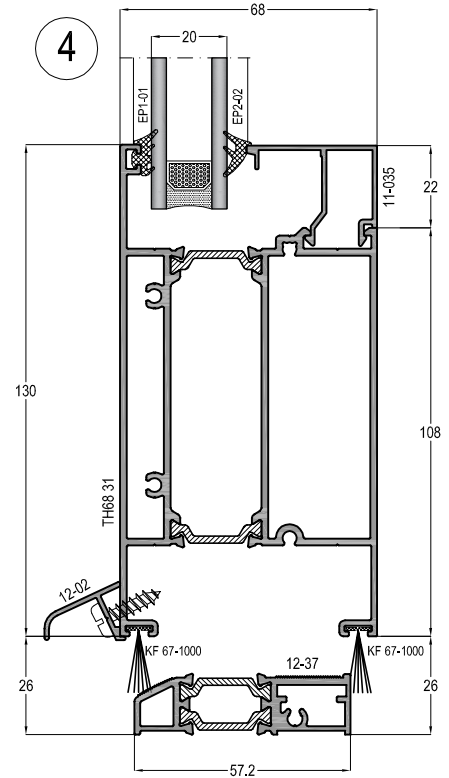

7

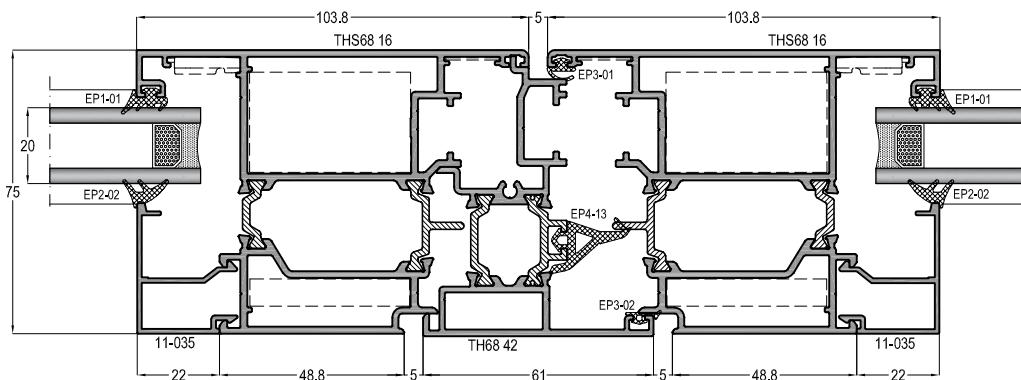

TH68 - 1,8mm

YALITIMLI KAPI-PENCERE SİSTEMİ
THERMAL WINDOW&DOOR SYSTEM

ASISTAL

KESİM ve MONTAJ
CUTTING & ASSEMBLY

TH68 - 1,8mm

YALITIMLI KAPI-PENCERE SİSTEMİ
THERMAL WINDOW&DOOR SYSTEM

ASISTAL

DİK (ORTA KAYIT) BAĞLANTI DETAYLARI T JOINT DETAILS

ÖNERİ : 1

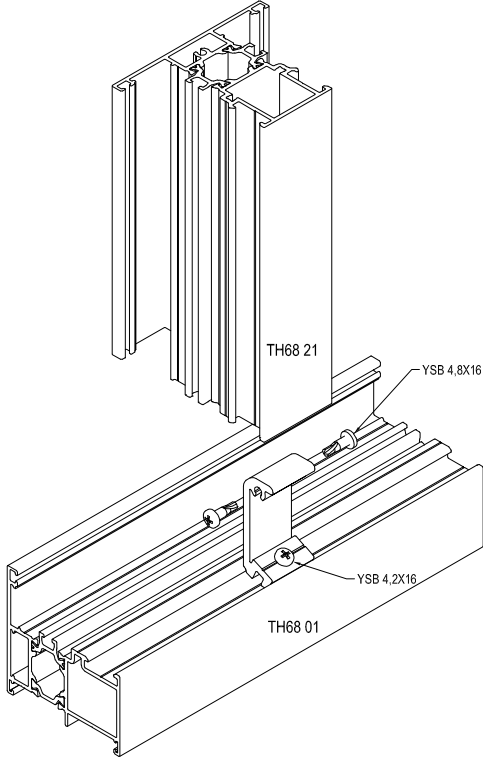

ÖNERİ : 2

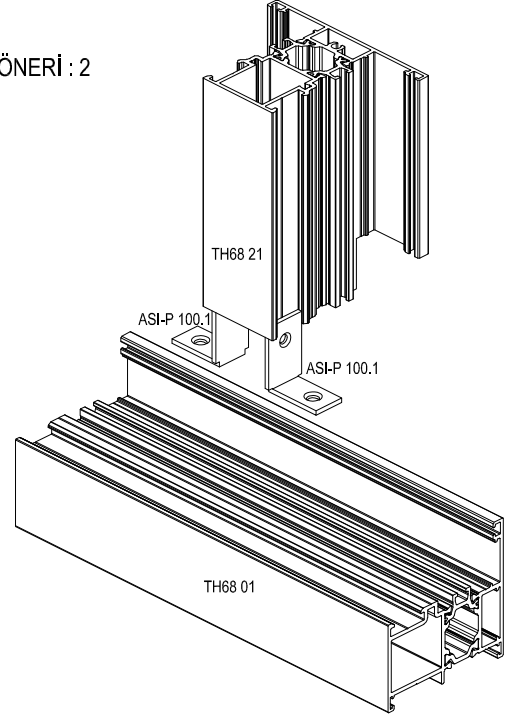

ÖNERİ : 3

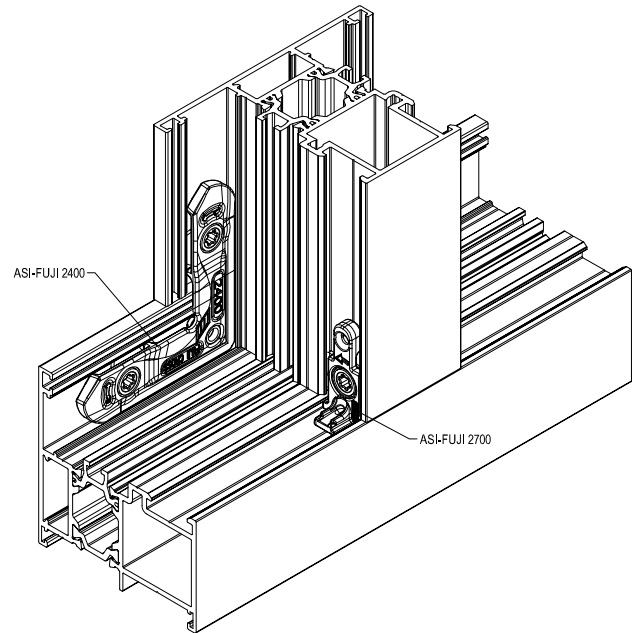
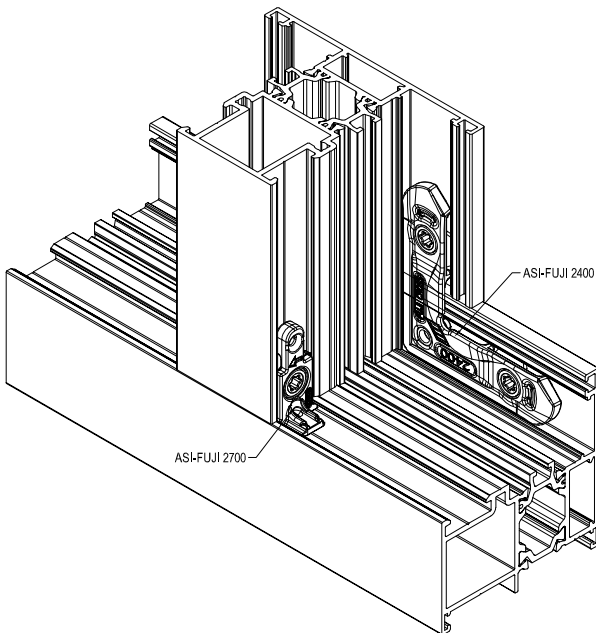

TH68 - 1,8mm

YALITIMLI KAPI-PENCERE SİSTEMİ
THERMAL WINDOW&DOOR SYSTEM

ASISTAL

KÖŞE ORTA BİNİ MONTAJI

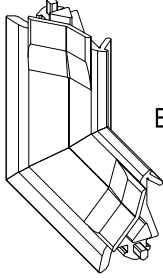

EP4-13K

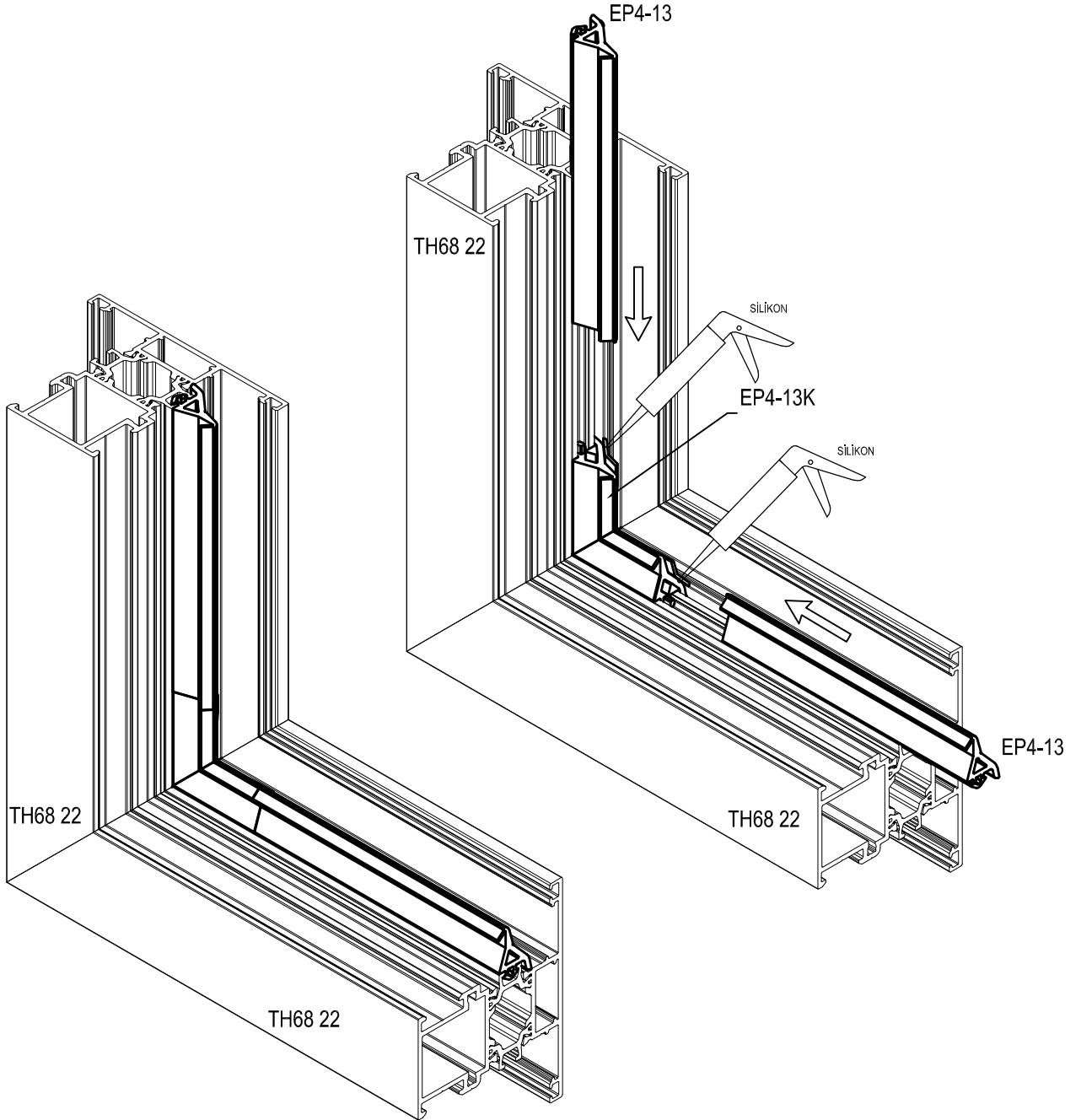
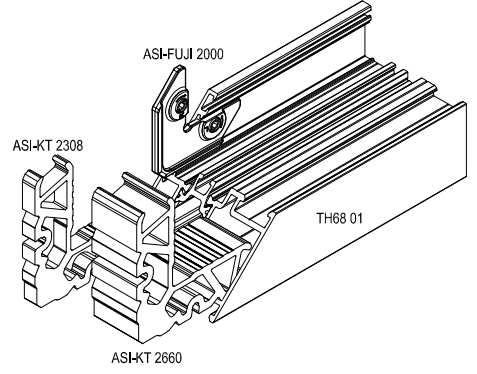

TH68 - 1,8mm

YALITIMLI KAPI-PENCERE SİSTEMİ
THERMAL WINDOW&DOOR SYSTEM

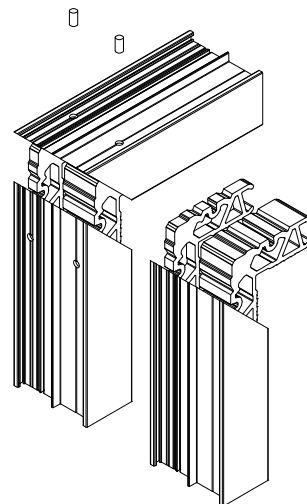
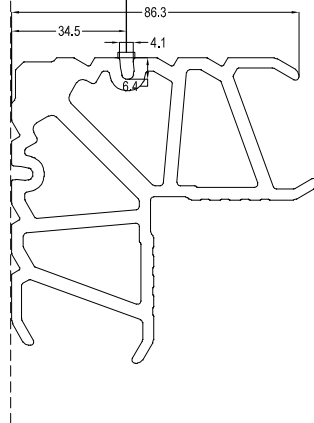
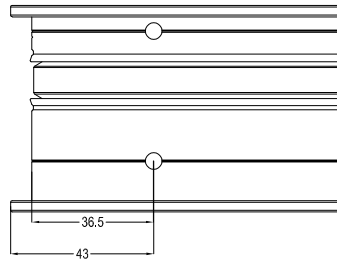
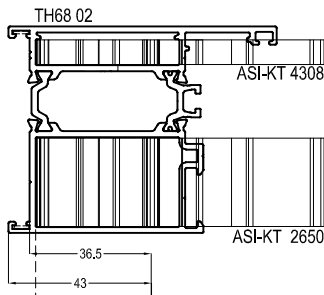
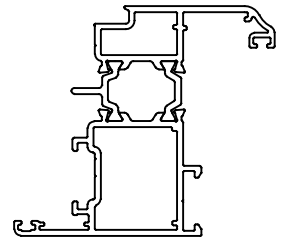
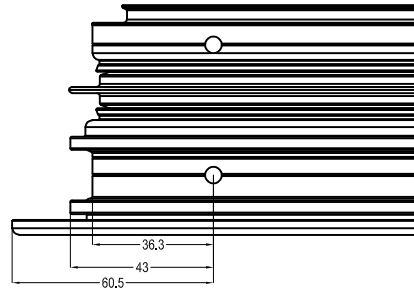
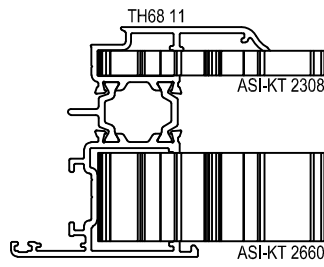
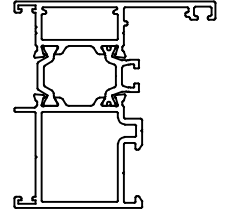
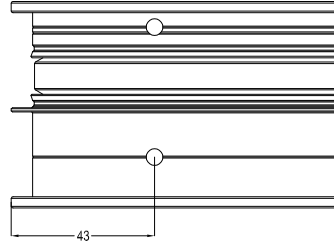
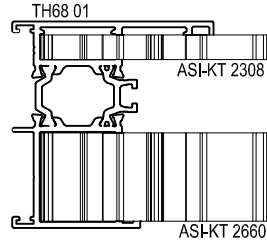
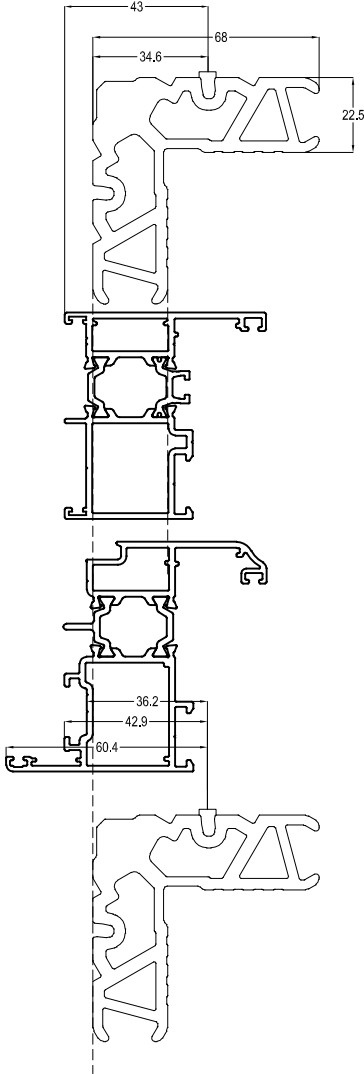

TH68 - 1,8mm

YALITIMLI KAPI-PENCERE SİSTEMİ
THERMAL WINDOW&DOOR SYSTEM

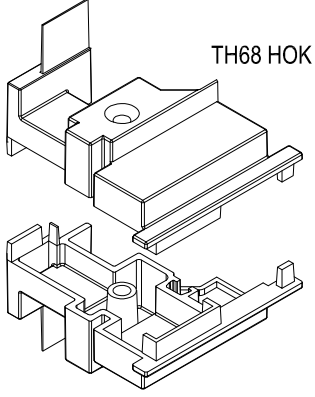

TH68 HOK

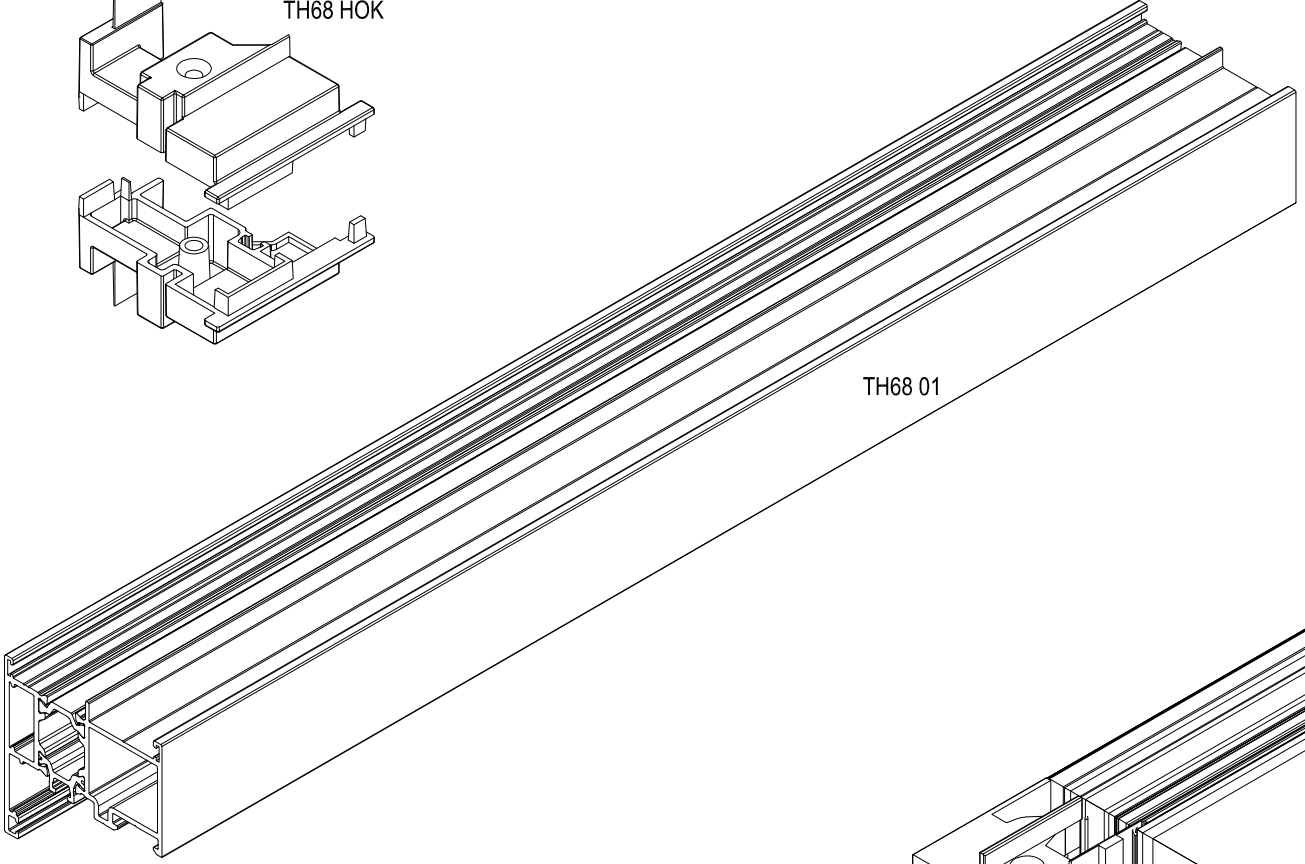

TH68 01

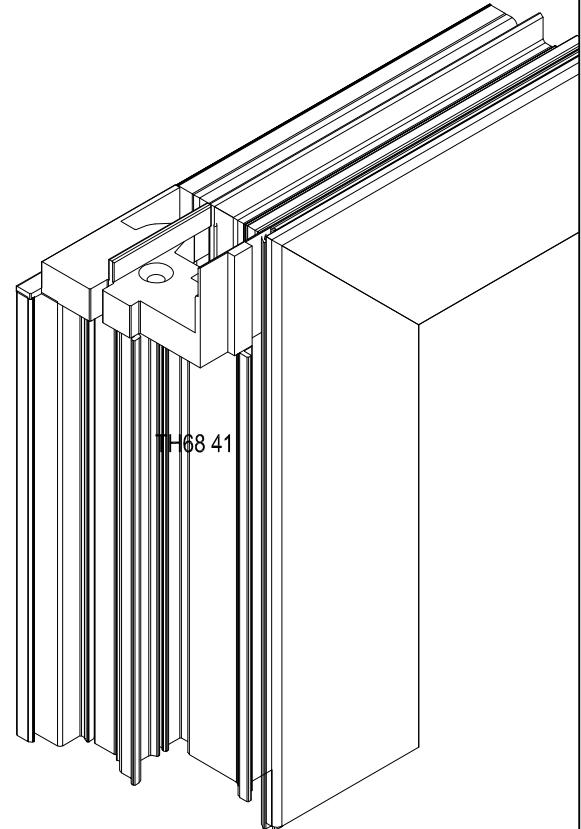
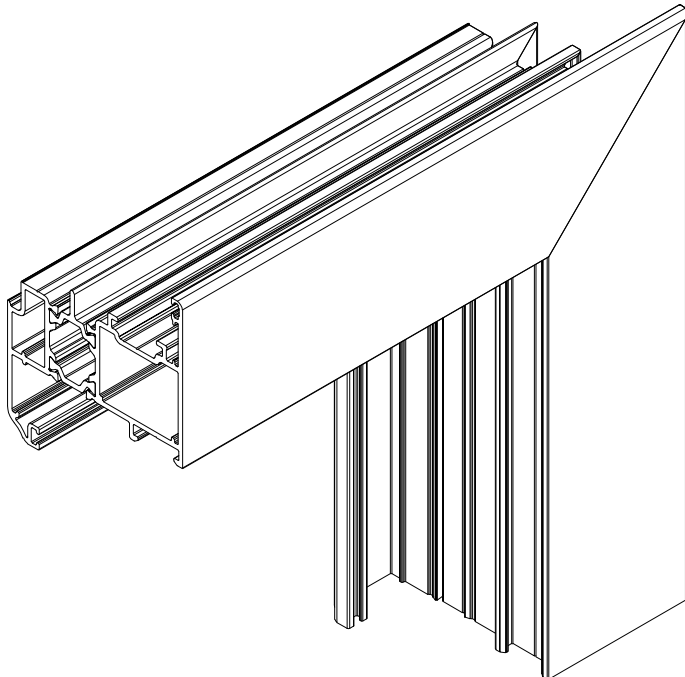

TH68 41

TH68 41 (H) = KANAT YÜKSEKLİĞİ - 69mm

TH62 - 1,8mm

YALITIMLI KAPI-PENCERE SİSTEMİ
THERMAL WINDOW&DOOR SYSTEM

ASISTAL

LAVAAL ÇİFT EKSEN AÇILIM AKSESUAR KULLANIM TABLOSU ALU - ALU TT

LAVAAL TILT&TURN OPENING ACCESSORIES TABLE

STANDART KİT / ASI-LTT-S01

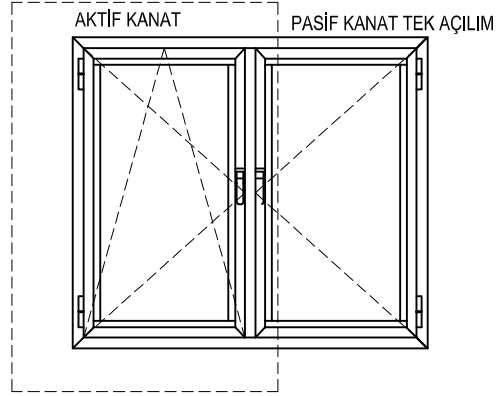
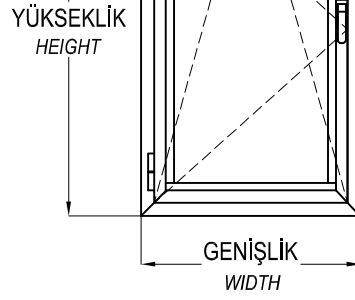
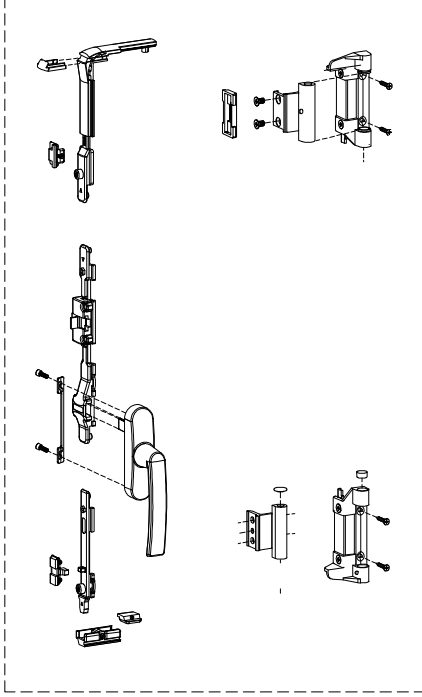

kanat eni	ASI-LTT-S01	ASI-LTT-M01	ASI-LTT-M02	ASI-LTT-M03	ASI-LTT-M04	ASI-LTT-B01
KANAT GENİŞLİK / Sash Widht : 345-400mm	X	X				
KANAT GENİŞLİK / Sash Widht : 401-540mm	X		X			
KANAT GENİŞLİK / Sash Widht : 541-1100mm	X			X		
KANAT GENİŞLİK / Sash Widht : 1100-1500mm	X			X	X	
KANAT YÜKSEKLİK / Sash Height : < 1400mm						X

TH62 - 1,8mm

YALITIMLI KAPI-PENCERE SİSTEMİ
THERMAL WINDOW&DOOR SYSTEM



LAVAAL ÇİFT EKSEN AÇILIM ÇİFT KANAT AKSESUAR KULLANIM TABLOSU ALU - ALU TT

LAVAAL TILT&TURN OPENING ACCESSORIES TABLE

STANDART KİT / ASI-LTT-S01

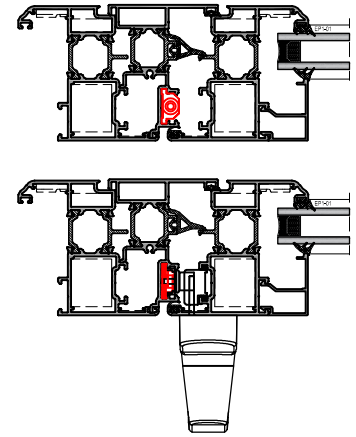
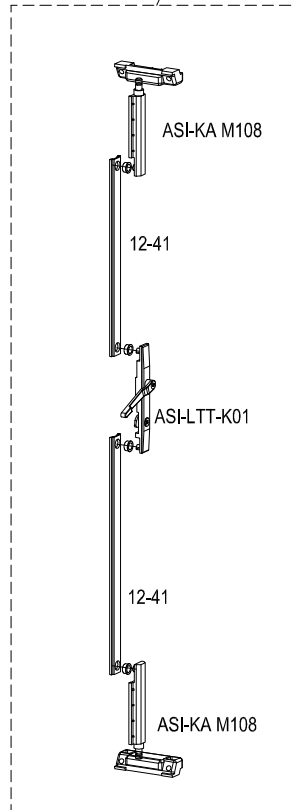
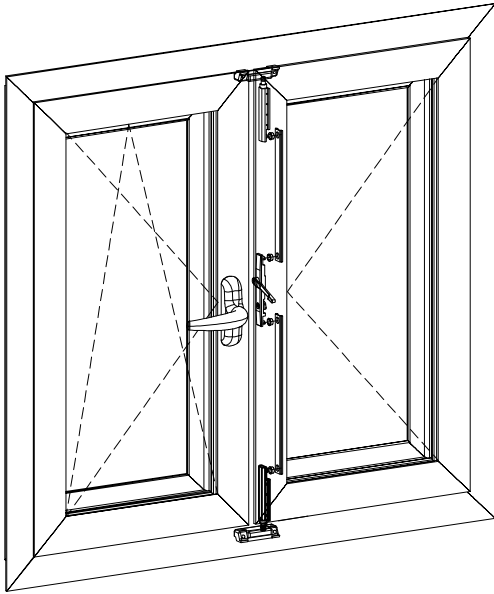
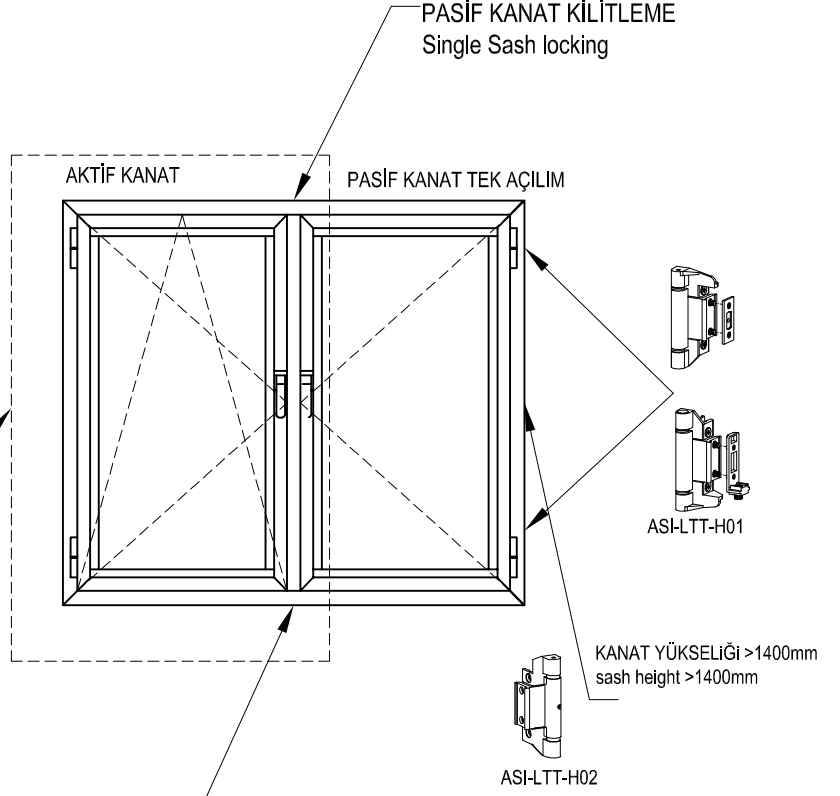
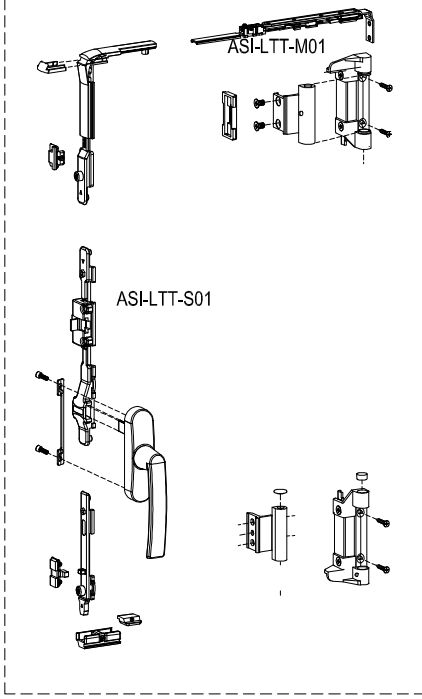

TH68 - 1,8mm

YALITIMLI KAPI-PENCERE SİSTEMİ
THERMAL WINDOW&DOOR SYSTEM

ASISTAL

MULTI POINT SİSTEM (PVC KANALLI) ÇİFT EKSEN AÇILIM AKSESUAR TABLOSU
MULTI POINT SYSTEM TILT&TURN OPENING ACCESSORIES TABLE

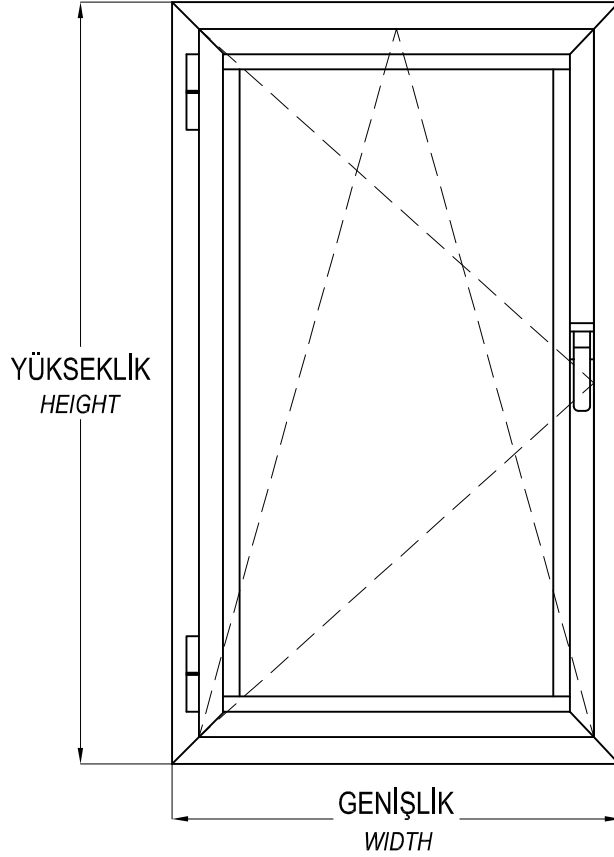

MULTI POINT (PVC KANALLI) KİLİTLEME AKSESUAR SEÇİM TABLOSU
MULTI POINT SYSTEM ACCESSORIES TABLE

YÜKSEKLİK- HEIGHT	GENİŞLİK - WIDTH			
	400-600mm	600-850mm	850-1100mm	1100-1350mm
450-700 mm	ASI-PVC TT 01	ASI-PVC TT 02	ASI-PVC TT 03	ASI-PVC TT 04
700-1200 mm	ASI-PVC TT 05	ASI-PVC TT 06	ASI-PVC TT 07	ASI-PVC TT 08
1200-1400 mm	ASI-PVC TT 09	ASI-PVC TT 10	ASI-PVC TT 11	ASI-PVC TT 12
1400-1700 mm	ASI-PVC TT 013	ASI-PVC TT 14	ASI-PVC TT 15	ASI-PVC TT 16
1700-2400 mm	ASI-PVC TT 017	ASI-PVC TT 18	ASI-PVC TT 19	ASI-PVC TT 20

TH68 - 1,8mm

YALITIMLI KAPI-PENCERE SİSTEMİ
THERMAL WINDOW&DOOR SYSTEM



MULTI POINT SİSTEM (PVC KANALLI) TEK EKSEN AÇILIM AKSESUARLARI
MULTI POINT SYSTEM SINGLE OPENING WINDOW ACCESSORIES

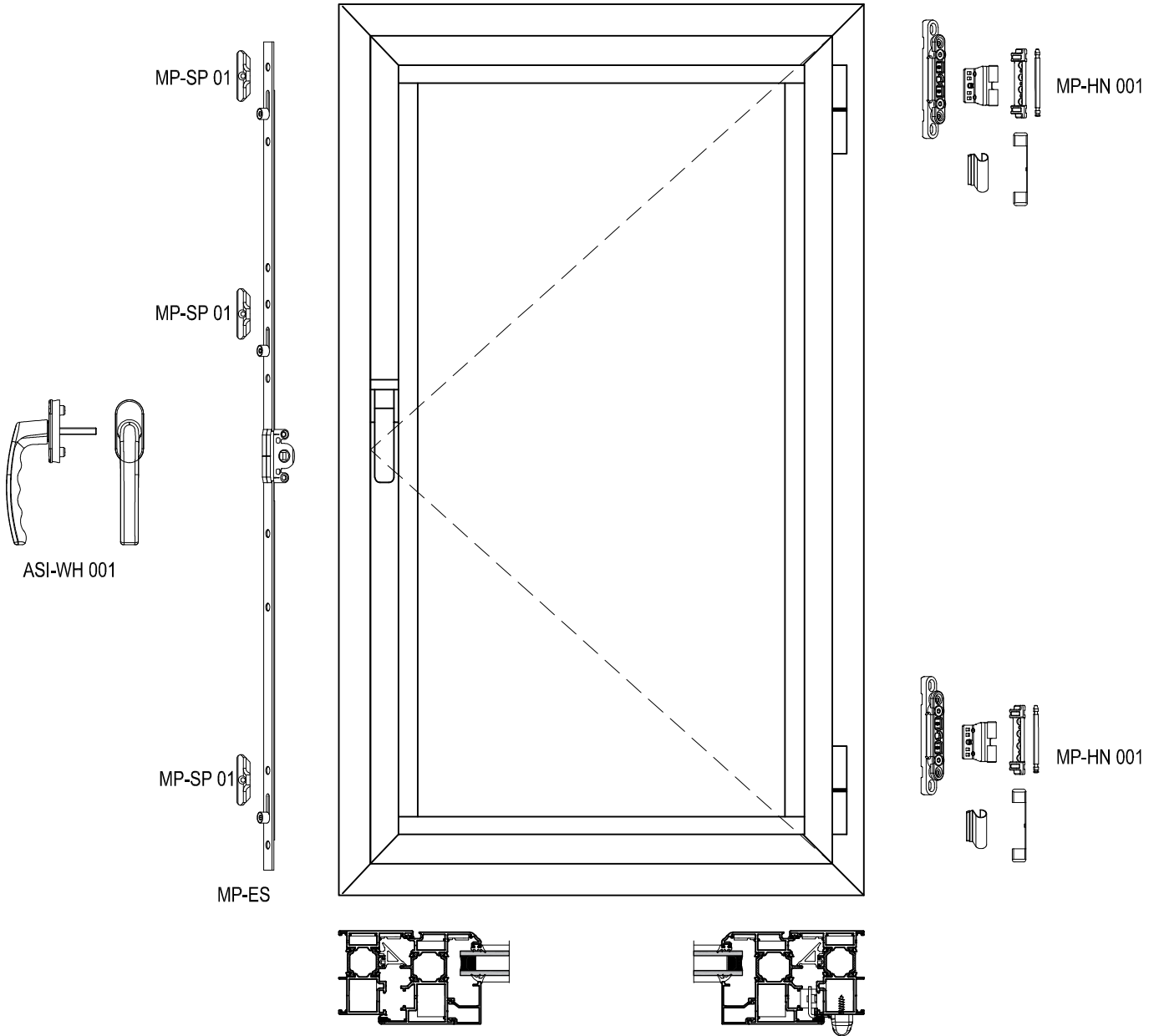

TH68 - 1,8mm

YALITIMLI KAPI-PENCERE SİSTEMİ
THERMAL WINDOW&DOOR SYSTEM



MULTI POINT SİSTEM (PVC KANALLI) TEK KANAT AÇILIM KAPI AKSESUARLARI
MULTI POINT SYSTEM INNER / OUTER OPENING DOOR ACCESSORIES

MP-HN 002

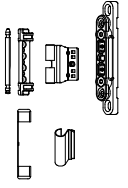

MP-HN 002

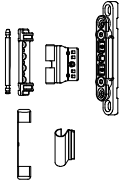

MP-HN 002

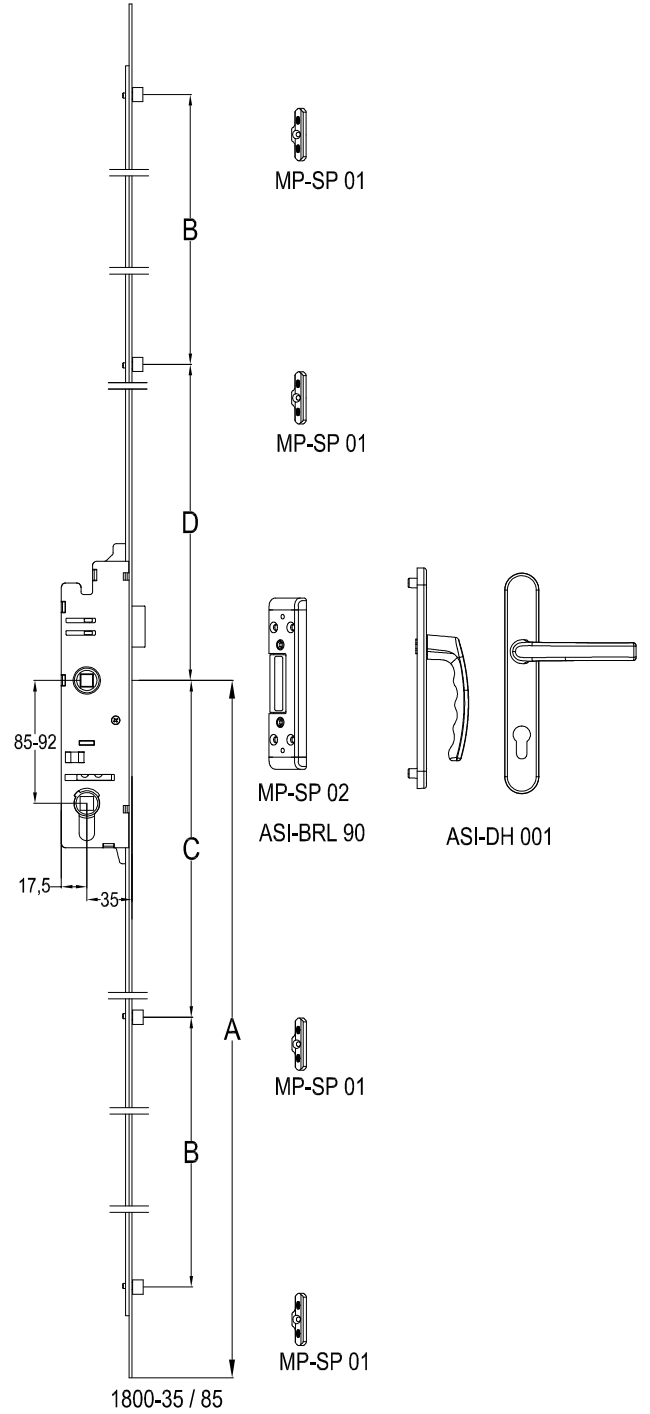
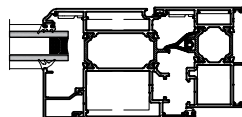
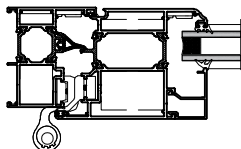
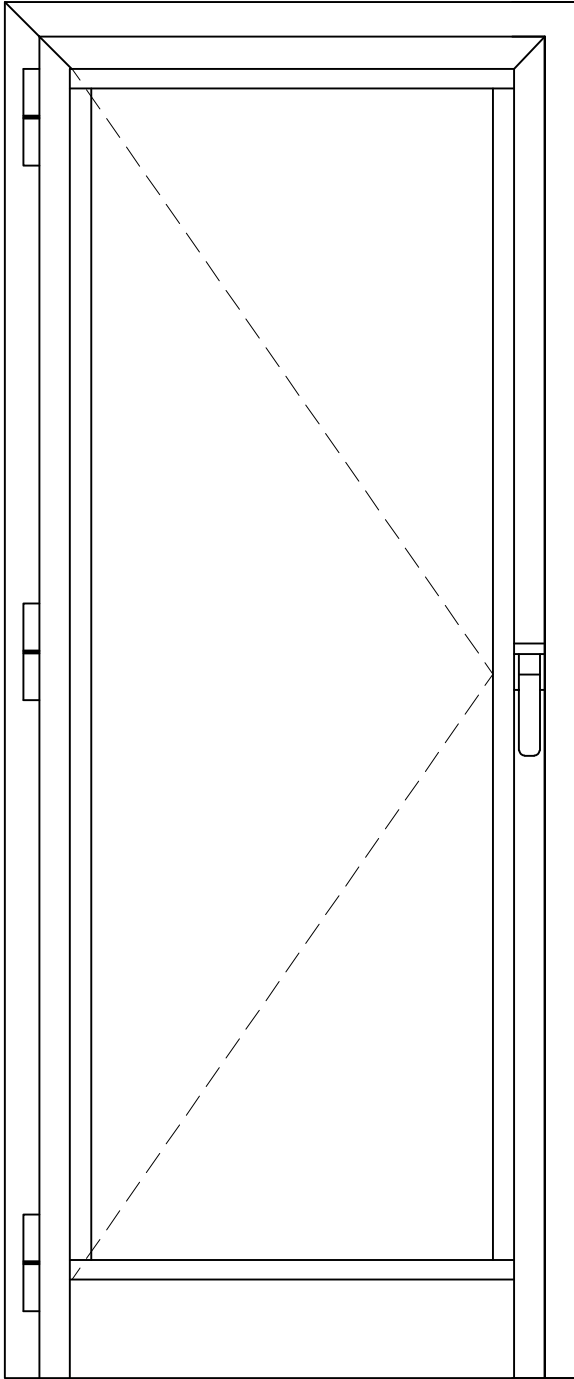
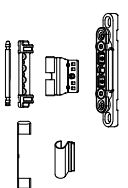

TH68 - 1,8mm

YALITIMLI KAPI-PENCERE SİSTEMİ
THERMAL WINDOW&DOOR SYSTEM

ASISTAL

TEK KANAT AÇILIM KESİM ÖLÇÜLERİ SINGLE SASH CUTTING SIZES

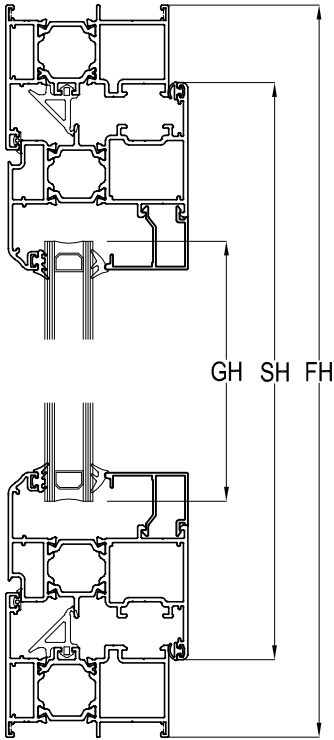
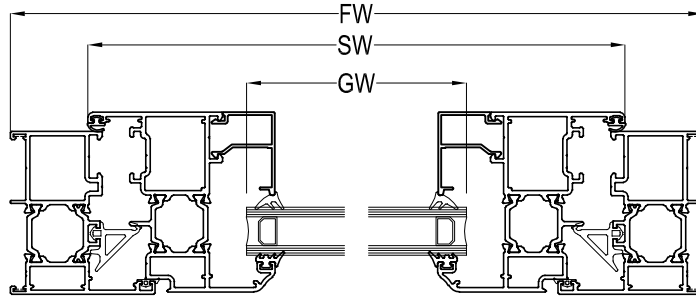
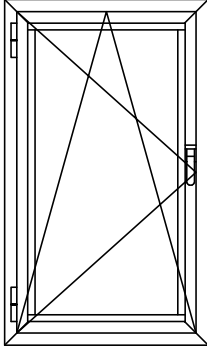

KASA PROFİLİ FRAME PROFILE	KANAT PROFİLİ SASH PROFILE	KESİM ÖLÇÜLERİ CUTTING SIZES
TH68 01 TH68 01 TH68 01	TH68 11 THS68 11 TH68 18	SW = FW - 64,8mm GW = SW - 122,4mm SH = FH - 64,8mm GH = SH - 122,4mm
TH68 01 TH68 01	TH68 12 THS68 12	SW = FW - 64,8mm GW = SW - 162,8mm SH = FH - 64,8mm GH = SH - 162,8mm
TH68 02 TH68 02 TH68 02	TH68 11 THS68 11 TH68 18	SW = FW - 105,2mm GW = SW - 122,4mm SH = FH - 105,2mm GH = SH - 122,4mm
TH68 02 TH68 02	TH68 12 THS68 12	SW = FW - 105,2mm GW = SW - 162,8mm SH = FH - 105,2mm GH = SH - 162,8mm

FW= KASA GENİŞLİĞİ / FRAME WIDTH
SW= KANAT GENİŞLİĞİ / SASH WIDTH
GW= CAM GENİŞLİĞİ / GLASS WIDTH

FH= KASA YÜKSEKLİĞİ / FRAME HEIGHT
SH= KANAT YÜKSEKLİĞİ / SASH HEIGHT
GH= CAM YÜKSEKLİĞİ / GLASS HEIGHT

TH68 - 1,8mm

YALITIMLI KAPI-PENCERE SİSTEMİ
THERMAL WINDOW&DOOR SYSTEM

ASISTAL

ÇİFT KANAT AÇILIM KESİM ÖLÇÜLERİ DOUBLE SASH CUTTING SIZES

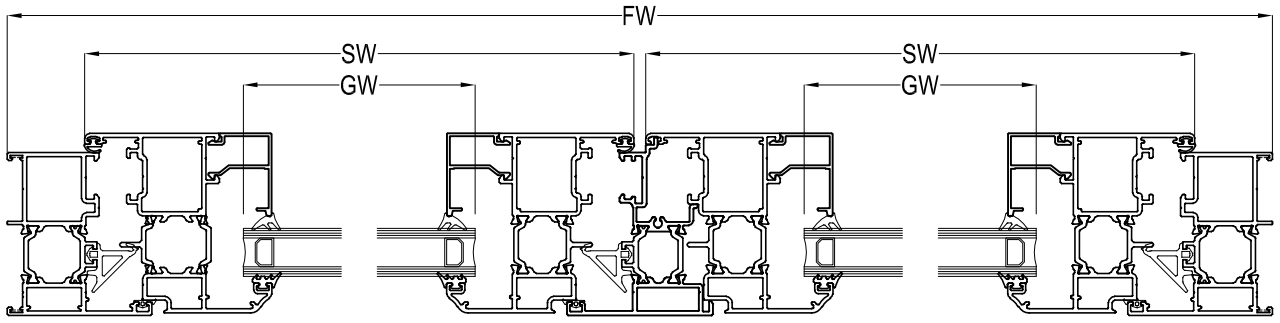

ADAPTÖR PROFİLİ
TH68 41 = SH - 69mm

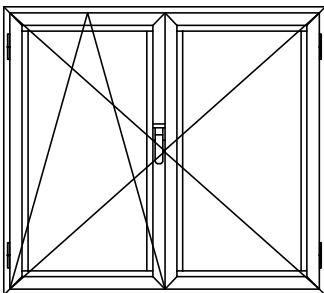
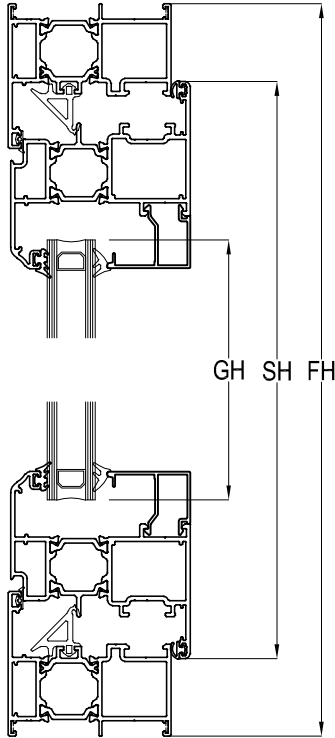

KASA PROFİLİ FRAME PROFILE	KANAT PROFİLİ SASH PROFILE	KESİM ÖLÇÜLERİ CUTTING SIZES
TH68 01 TH68 01 TH68 01	TH68 11 THS68 11 TH68 18	SW = FW / 2 - 34,9mm GW = SW - 122,4mm SH = FH - 64,8mm GH = SH - 122,4mm
TH68 01 TH68 01	TH68 12 THS68 12	SW = FW / 2 - 34,9mm GW = SW - 162,8mm SH = FH - 64,8mm GH = SH - 162,8mm
TH68 02 TH68 02 TH68 02	TH68 11 THS68 11 TH68 18	SW = FW / 2 - 55,1mm GW = SW - 122,4mm SH = FH - 105,2mm GH = SH - 122,4mm
TH68 02 TH68 02	TH68 12 THS68 12	SW = FW / 2 - 55,1mm GW = SW - 162,8mm SH = FH - 105,2mm GH = SH - 162,8mm

FW= KASA GENİŞLİĞİ / FRAME WIDTH
SW= KANAT GENİŞLİĞİ / SASH WIDTH
GW= CAM GENİŞLİĞİ / GLASS WIDTH

FH= KASA YÜKSEKLİĞİ / FRAME HEIGHT
SH= KANAT YÜKSEKLİĞİ / SASH HEIGHT
GH= CAM YÜKSEKLİĞİ / GLASS HEIGHT

TH68 - 1,8mm

YALITIMLI KAPI-PENCERE SİSTEMİ
THERMAL WINDOW&DOOR SYSTEM

ASISTAL

MULTI POINT (PVC KANALLI) TEK KANAT AÇILIM KESİM ÖLÇÜLERİ MULTI POINT SINGLE SASH CUTTING SIZES

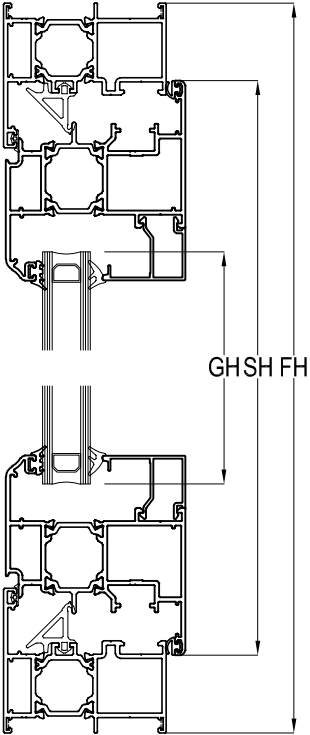
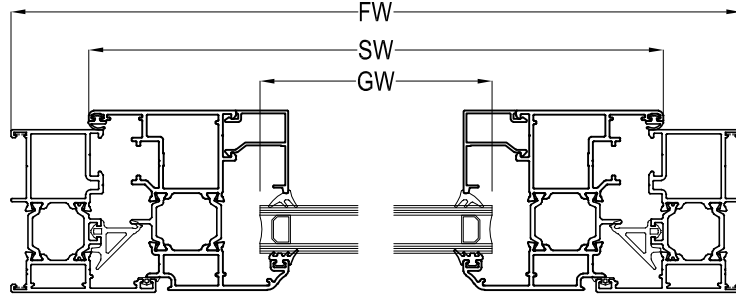
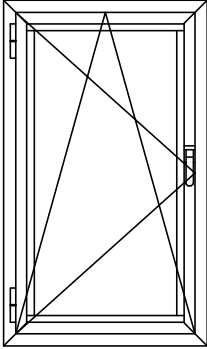

KASA PROFİLİ FRAME PROFILE	KANAT PROFİLİ SASH PROFILE	KESİM ÖLÇÜLERİ CUTTING SIZES
TH68 01 TH68 01	TH68 14 THS68 14	SW = FW - 64,8mm GW = SW - 133mm SH = FH - 64,8mm GH = SH - 133mm
TH68 01 TH68 01	TH68 15 THS68 15	SW = FW - 64,8mm GW = SW - 173,4mm SH = FH - 64,8mm GH = SH - 173,4mm
TH68 02 TH68 02	TH68 14 THS68 14	SW = FW - 105,2mm GW = SW - 133mm SH = FH - 105,2mm GH = SH - 133mm
TH68 02 TH68 02	TH68 15 THS68 15	SW = FW - 105,2mm GW = SW - 173,4mm SH = FH - 105,2mm GH = SH - 173,4mm

FW= KASA GENİŞLİĞİ / FRAME WIDTH
SW= KANAT GENİŞLİĞİ / SASH WIDTH
GW= CAM GENİŞLİĞİ / GLASS WIDTH

FH= KASA YÜKSEKLİĞİ / FRAME HEIGHT
SH= KANAT YÜKSEKLİĞİ / SASH HEIGHT
GH= CAM YÜKSEKLİĞİ / GLASS HEIGHT

TH68 - 1,8mm

YALITIMLI KAPI-PENCERE SİSTEMİ
THERMAL WINDOW&DOOR SYSTEM

ASISTAL

MULTI POINT (PVC KANALLI) ÇİFT KANAT AÇILIM KESİM ÖLÇÜLERİ MULTI POINT DOUBLE SASH CUTTING SIZES

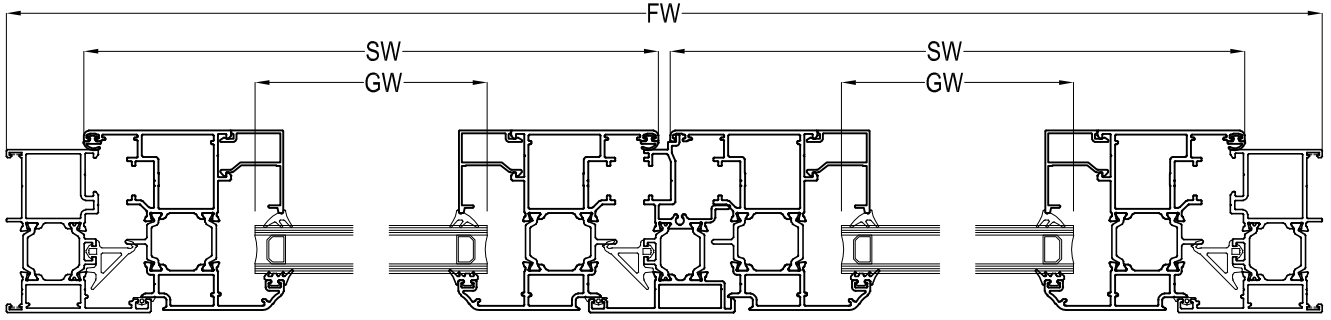

ADAPTÖR PROFİLİ
TH68 42 = SH - 69mm

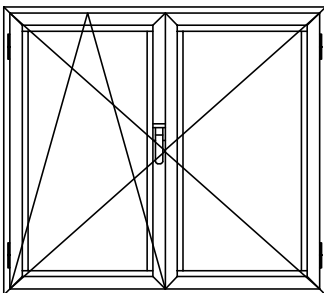
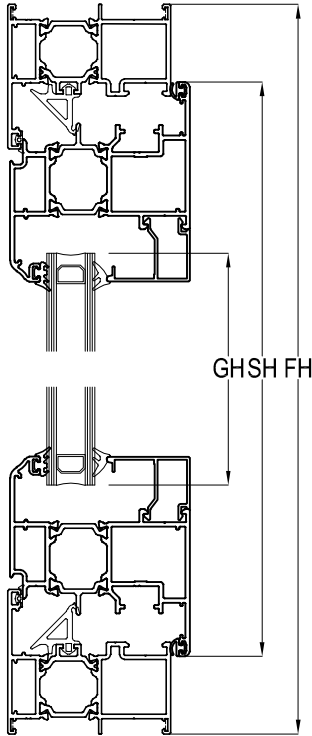

KASA PROFİLİ FRAME PROFILE	KANAT PROFİLİ SASH PROFILE	KESİM ÖLÇÜLERİ CUTTING SIZES
TH68 01 TH68 01	TH68 14 THS68 14	SW = FW / 2 - 34,9mm GW = SW - 133mm SH = FH - 64,8mm GH = SH - 133mm
TH68 01 TH68 01	TH68 15 THS68 15	SW = FW / 2 - 34,9mm GW = SW - 173,4mm SH = FH - 64,8mm GH = SH - 173,4mm
TH68 02 TH68 02	TH68 14 THS68 14	SW = FW / 2 - 55,1mm GW = SW - 133mm SH = FH - 105,2mm GH = SH - 133mm
TH68 02 TH68 02	TH68 15 THS68 15	SW = FW / 2 - 55,1mm GW = SW - 173,4mm SH = FH - 105,2mm GH = SH - 173,4mm

FW= KASA GENİŞLİĞİ / FRAME WIDTH
SW= KANAT GENİŞLİĞİ / SASH WIDTH
GW= CAM GENİŞLİĞİ / GLASS WIDTH

FH= KASA YÜKSEKLİĞİ / FRAME HEIGHT
SH= KANAT YÜKSEKLİĞİ / SASH HEIGHT
GH= CAM YÜKSEKLİĞİ / GLASS HEIGHT