











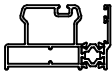

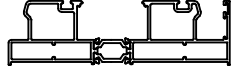

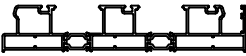

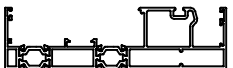

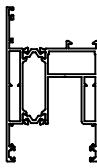
**LS60 - 1,8mm**

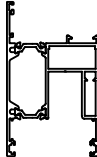
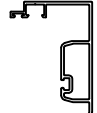
YALITIMLI KALDIR-SÜR SİSTEMİ  
THERMAL LIFT&SLIDE SYSTEM

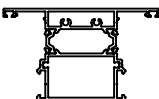
**ASISTAL**

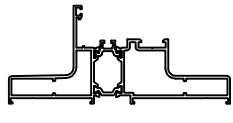
**PROFİL VE AKSESUAR LİSTELERİ**  
*PROFILE & ACCESSORIES LIST*

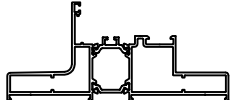
### PROFİL LİSTESİ - PROFILES LIST

LS60 01			LS60 41		
KASA PROFİLİ FRAME PROFILE	AĞIRLIK / Weight 1,582 kg/mt		ADAPTÖR PROFİLİ ADAPTER PROFILE	AĞIRLIK / Weight 0,967 kg/mt	
LS60 02			LS60 31		
KASA PROFİLİ FRAME PROFILE	AĞIRLIK / Weight 2,810 kg/mt		KAPAK PROFİLİ COVER PROFILE	AĞIRLIK / Weight 0,685 kg/mt	
LS60 03			LS60 32		
KASA PROFİLİ FRAME PROFILE	AĞIRLIK / Weight 4,188 kg/mt		DEKORATİF KAPAK PROFİLİ DECORATIVE COVER PROFILE	AĞIRLIK / Weight 0,709 kg/mt	
LS60 04			LS60 33		
KASA PROFİLİ FRAME PROFILE	AĞIRLIK / Weight 2,749 kg/mt		KAPAK PROFİLİ COVER PROFILE	AĞIRLIK / Weight 0,523 kg/mt	
LS60 11			LS60 34		
	Jx cm <sup>4</sup> 43,22		Jy cm <sup>4</sup> 49,37	DEKORATİF KAPAK PROFİLİ DECORATIVE COVER PROFILE	
LS60 12			LS60 43		
KANAT PROFİLİ SASH PROFILE	AĞIRLIK / Weight 2,314 kg/mt		3'LÜ KANAT ADAPTÖR PROFİLİ ADAPTER PROFILE	AĞIRLIK / Weight 1,112 kg/mt	
LS60 42			LS60 61		
KENET PROFİLİ CENTRAL LOCKING PROFILE	AĞIRLIK / Weight 0,669 kg/mt		SİNEKLİK RAY PROFİLİ FLYSCREEN RAIL PROFILE	AĞIRLIK / Weight 0,391 kg/mt	
TH60 23			15-304216-09		
ORTA KAYIT PROFİLİ TRANSOM-MULLION PROFILE	AĞIRLIK / Weight 2,130 kg/mt		SİNEKLİK KANAT PROFİLİ FLYSCREEN SASH PROFILE	AĞIRLIK / Weight 0,351 kg/mt	
LS60 62			15-306317-11		
TH62 SİSTEM GEÇİŞ KASA PROFİLİ FRAME PROFILE FOR TH62	AĞIRLIK / Weight 2,423 kg/mt		SİNEKLİK KANAT PROFİLİ FLYSCREEN SASH PROFILE	AĞIRLIK / Weight 0,561 kg/mt	
LS60 68			LS60 35		
TH68 SİSTEM GEÇİŞ KASA PROFİLİ FRAME PROFILE FOR TH68	AĞIRLIK / Weight 2,411 kg/mt		KANAT SABİTLEME PROFİLİ SASH FIXING PROFILE	AĞIRLIK / Weight 0,672 kg/mt	

















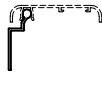

\* Sipariş öncesi kalıp bilgisi kontrol edilmeli / must be check profile mold before the order

Profil ağırlıklarımız teorik olup; teslim anındaki tartımız geçerlidir.



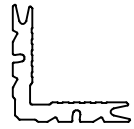

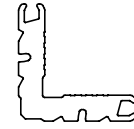















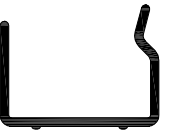

## PROFİL LİSTESİ - PROFILES LIST

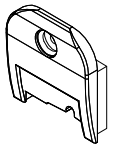

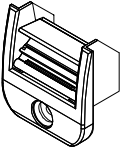
11-004			11-032		
CAM ÇİTASI-4 mm GLAZING BEAD PROFILE	AĞIRLIK / Weight 0,181 kg/mt		CAM ÇİTASI-32 mm GLAZING BEAD PROFILE	AĞIRLIK / Weight 0,315 kg/mt	
11-106			11-035		
CAM ÇİTASI-6 mm GLAZING BEAD PROFILE	AĞIRLIK / Weight 0,200 kg/mt		CAM ÇİTASI-35 mm GLAZING BEAD PROFILE	AĞIRLIK / Weight 0,323 kg/mt	
11-010			11-038		
CAM ÇİTASI-10 mm GLAZING BEAD PROFILE	AĞIRLIK / Weight 0,233 kg/mt		CAM ÇİTASI-38 mm GLAZING BEAD PROFILE	AĞIRLIK / Weight 0,334 kg/mt	
11-015			12-52		
CAM ÇİTASI-15 mm GLAZING BEAD PROFILE	AĞIRLIK / Weight 0,241 kg/mt		PERVAZ PROFİLİ BORDER PROFILE	AĞIRLIK / Weight 0,279 kg/mt	
11-017			12-53		
CAM ÇİTASI-17 mm GLAZING BEAD PROFILE	AĞIRLIK / Weight 0,250 kg/mt		PERVAZ MONTAJ PROFİLİ BORDER FIXING PROFILE	AĞIRLIK / Weight 0,177 kg/mt	
11-020			LS60 44		
CAM ÇİTASI-20 mm GLAZING BEAD PROFILE	AĞIRLIK / Weight 0,276 kg/mt		İSPANYOLET KİLİTLEME ADAPTÖR PROFİLİ MULTI POINT LOCK ADAPTER	AĞIRLIK / Weight 0,284 kg/mt	
11-022			SL-1515		
CAM ÇİTASI-22 mm GLAZING BEAD PROFILE	AĞIRLIK / Weight 0,282 kg/mt		KASA MONTAJ PROFİLİ FRAME ASSEMBLY PROFILE	AĞIRLIK / Weight 0,092 kg/mt	
11-026			10-010106-00		
CAM ÇİTASI-26 mm GLAZING BEAD PROFILE	AĞIRLIK / Weight 0,296 kg/mt		KÖŞE TAKOZU-10,6 mm CORNER JOINT	AĞIRLIK / Weight 2,653 kg/mt	
11-028			10-010140-00		
CAM ÇİTASI-28 mm GLAZING BEAD PROFILE	AĞIRLIK / Weight 0,302 kg/mt		KÖŞE TAKOZU-14,2 mm CORNER JOINT	AĞIRLIK / Weight 3,582 kg/mt	
11-030			10-010225-00		
CAM ÇİTASI-30 mm GLAZING BEAD PROFILE	AĞIRLIK / Weight 0,308 kg/mt		KÖŞE TAKOZU-22,5 mm CORNER JOINT	AĞIRLIK / Weight 3,564 kg/mt	

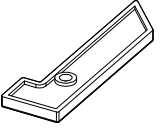

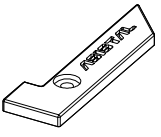

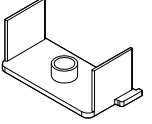
## AKSESUAR LİSTESİ - ACCESSORIES LIST

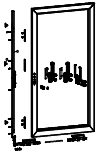
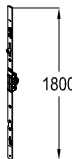
EP1-01			KF 67-700		
DIŞ CAM FİTİLİ - 2,5 mm OUTER GLAZING GASKET	KOLİ MİKTARI/Package 240 mt / 15 kg		FİRÇA FİTİL-7mm BRUSH GASKET	KOLİ MİKTARI/Package 1100 mt / koli	
EP2-01			KF 67-1000		
İÇ CAM FİTİLİ - 3 mm INNER GLAZING GASKET	KOLİ MİKTARI/Package 440 mt / 15 kg		FİRÇA FİTİL-10mm BRUSH GASKET	KOLİ MİKTARI/Package 600 mt / koli	
EP2-02			MO60-10		
İÇ CAM FİTİLİ - 4 mm INNER GLAZING GASKET	KOLİ MİKTARI/Package 300 mt / 15 kg		KENET PVC PROFİL CENTRAL LOCKING PVC PROFILE	KOLİ MİKTARI/Package 6 mt / Adet	
EP2-03			MO60-07		
İÇ CAM FİTİLİ - 5 mm INNER GLAZING GASKET	KOLİ MİKTARI/Package 250 mt / 15 kg		KASA KANAL PLASTİĞİ LS60 04 KASA İÇİN PVC PROFILE FOR LS60 04	KOLİ MİKTARI/Package 6 mt / Adet	
EP60-03			MO60-08		
KANAT ÜST FİTİLİ SASH GASKET	KOLİ MİKTARI/Package 330 mt / 15 kg		KASA KANAL PLASTİĞİ LS60 02 ve LS60 03 İÇİN PVC PROFILE FOR LS60 02 & LS60 03	KOLİ MİKTARI/Package 6 mt / Adet	
EP60-04			MO60-01		
KENET FİTİLİ CENTRAL LOCKING GASKET	KOLİ MİKTARI/Package 300 mt / 15 kg		KENET KAPAĞI-ALT INTERLOCK PROFILE-BOTTOM	KOLİ MİKTARI/Package Adet / Piece	
EP60-05			MO60-02		
KANAT FİTİLİ SASH GASKET	KOLİ MİKTARI/Package 300 mt / 15 kg		KENET KAPAĞI-ÜST INTERLOCK PROFILE-TOP	KOLİ MİKTARI/Package Adet / Piece	
INT1-01			MO60-03		
KASA FİTİLİ FRAME GASKET	KOLİ MİKTARI/Package 500 mt / 15 kg		MO60-10 İÇİN KAPAK-ALT COVER FOR MO60-10-BOTTOM	KOLİ MİKTARI/Package Adet / Piece	
INT2-02			MO60-04		
KANAL FİTİLİ ADAPTER GASKET	KOLİ MİKTARI/Package 350 mt / 15 kg		MO60-10 İÇİN KAPAK-ÜST COVER FOR MO60-10-TOP	KOLİ MİKTARI/Package Adet / Piece	
KF 67-600			MO60-12		
FİRÇA FİTİL-6mm BRUSH GASKET	KOLİ MİKTARI/Package 1300 mt / koli		4 LÜ KANAT KİLİTLEME ADAPTÖR KAPAĞI MEETING STILE CAP	KOLİ MİKTARI/Package Adet / Piece	

<b>MO60-13</b>			<b>LS60-MEK2</b>		
KANAT Dengeleme PLASTİĞİ SASH STABILIZATION SPACER	KOLİ MİKTARI/Package Adet / Piece		200 kg KAPASİTELİ KALDIR-SÜR MEKANİZMA LIFT & SLIDE MECHANISM	KOLİ MİKTARI/Package Takım / Set	
<b>MO60-05D</b>			<b>LS60-MEK2D</b>		
ALT HAVA KESİCİ LS60 04 KASA İÇİN CENTRAL SEALING-BOTTOM FOR LS60 04	KOLİ MİKTARI/Package Adet / Piece		200 kg KAPASİTELİ 4'LÜ KANAT MEKANİZMA LIFT & SLIDE MECHANISM	KOLİ MİKTARI/Package Takım / Set	
<b>MO60-05G</b>			<b>ASI-ISP15.1</b>		
ALT HAVA KESİCİ CENTRAL SEALING-BOTTOM	KOLİ MİKTARI/Package Adet / Piece		İSPANYOLET KİLİTLEME (600mm) - 15.5 AKS MULTI POINT LOCK	KOLİ MİKTARI/Package Adet / Piece	
<b>MO60-06D</b>			<b>ASI-ISP15.2</b>		
ÜST HAVA KESİCİ LS60 04 KASA İÇİN CENTRAL SEALING-TOP FOR LS60 04	KOLİ MİKTARI/Package Adet / Piece		İSPANYOLET KİLİTLEME (1000mm)-15.5 AKS MULTI POINT LOCK	KOLİ MİKTARI/Package Adet / Piece	
<b>MO60-06G</b>			<b>ASI-ISP15.3</b>		
ÜST HAVA KESİCİ CENTRAL SEALING-TOP	KOLİ MİKTARI/Package Adet / Piece		İSPANYOLET KİLİTLEME (1800mm) - 15.5 AKS MULTI POINT LOCK	KOLİ MİKTARI/Package Adet / Piece	
<b>MO60-19</b>			<b>ASI-ISP K03</b>		
KOL PROFİL KAPAĞI HANDLE PROFILE CAP	KOLİ MİKTARI/Package alt-üst takım / set		İSPANYOLET KİLİT KARŞILIK MULTI POINT LOCK STRIKER	KOLİ MİKTARI/Package Adet / Piece	
<b>LS60-DB 3560</b>			<b>ASI-WH 002</b>		
KANAT SABİTLEME PARÇASI SASH FIXING	KOLİ MİKTARI/Package Adet / Piece		İSPANYOLET KİLİTLEME KOL MULTI POINT LOCK HANDLE	KOLİ MİKTARI/Package Adet / Piece	
<b>ASI-WDC 01</b>			<b>ASI-LS-H01</b>		
YAĞMUR TAHLİYE KAPAĞI WATER REJECT COVER	KOLİ MİKTARI/Package Adet / Piece		LAVAAL KALDIR-SÜR KOLU LIFT&SLIDE HANDLE	KOLİ MİKTARI/Package Takım / Set	
<b>LS60-MEK1</b>			<b>ASI-LS-H01A</b>		
300 kg KAPASİTELİ KALDIR-SÜR MEKANİZMA LIFT & SLIDE MECHANISM	KOLİ MİKTARI/Package Takım / Set		LAVAAL KALDIR-SÜR KOLU TEKLİ LIFT&SLIDE HANDLE SINGLE	KOLİ MİKTARI/Package Adet / Piece	
<b>LS60-MEK1D</b>			<b>ASI-LS-H02</b>		
300 kg KAPASİTELİ 4'LÜ KANAT MEKANİZMA LIFT & SLIDE MECHANISM	KOLİ MİKTARI/Package Takım / Set		LAVAAL KALDIR-SÜR KOLU KİLİTLİ LIFT&SLIDE HANDLE LOCK	KOLİ MİKTARI/Package Takım / Set	



## AKSESUAR LİSTESİ - ACCESSORIES LIST

<b>ASI-SR 04</b>			<b>ASI-5025</b>		
NORMAL SÜRME RULMAN (U TİPİ RAY) NORMAL SLIDING ROLLER FOR RAIL TYPE - U	KOLİ MİKTARI/Package Adet / Piece		SİNEKLİK FİTİLİ FLYSCREEN GASKET	KOLİ MİKTARI/Package 100 mt	
<b>ASI-INR 01</b>			<b>ASI-BZ 5060</b>		
ÇELİK RAY STEEL RAIL	KOLİ MİKTARI/Package 3 mt / Adet		SİNEKLİK KANAT RULMAN FLYSCREEN SASH ROLLER	KOLİ MİKTARI/Package Adet / Piece	
<b>ASI-SB 19.1</b>			<b>ASI-BZ 5007</b>		
KÖŞE GÖNYESİ CORNER ALIGNMENT	KOLİ MİKTARI/Package 1000 Adet / Piece		SİNEKLİK KÖŞE TAKOZU FLYSCREEN CORNER JOINT	KOLİ MİKTARI/Package Adet / Piece	
<b>ASI-PB 1126</b>					
PİMLİ KÖŞE BAĞLANTI CORNER JOINT	KOLİ MİKTARI/Package Adet / Piece				
<b>ASI-KT 1126</b>					
KÖŞE TAKOZU CORNER JOINT	KOLİ MİKTARI/Package Adet / Piece				
<b>ASI-KT 1429</b>					
KÖŞE TAKOZU CORNER JOINT	KOLİ MİKTARI/Package Adet / Piece				
<b>ASI-KT 2307</b>					
KÖŞE TAKOZU CORNER JOINT	KOLİ MİKTARI/Package Adet / Piece				
<b>ASI-DB 9143</b>					
DİK BAĞLANTI T JOINT	KOLİ MİKTARI/Package Adet / Piece				
<b>ASI-SL1520</b>					
KASA MONTAJ PARÇASI FRAME ASSEMBLY PART	KOLİ MİKTARI/Package Adet / Piece				

**LS60 - 1,8mm**

YALITIMLI KALDIR-SÜR SİSTEMİ  
THERMAL LIFT&SLIDE SYSTEM

**ASISTAL**

**PROFİL DETAYLARI**  
*PROFILE DETAILS*

# LS60 - 1,8mm

YALITIMLI KALDIR-SÜR SİSTEM  
THERMAL LIFT&SLIDE SYSTEM

**ASISTAL**

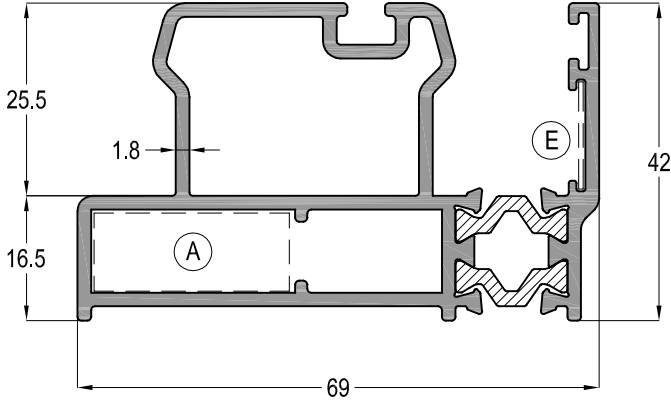

## LS60 01

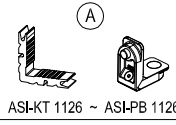

AĞIRLIK / Weight

1,582 kg/mt

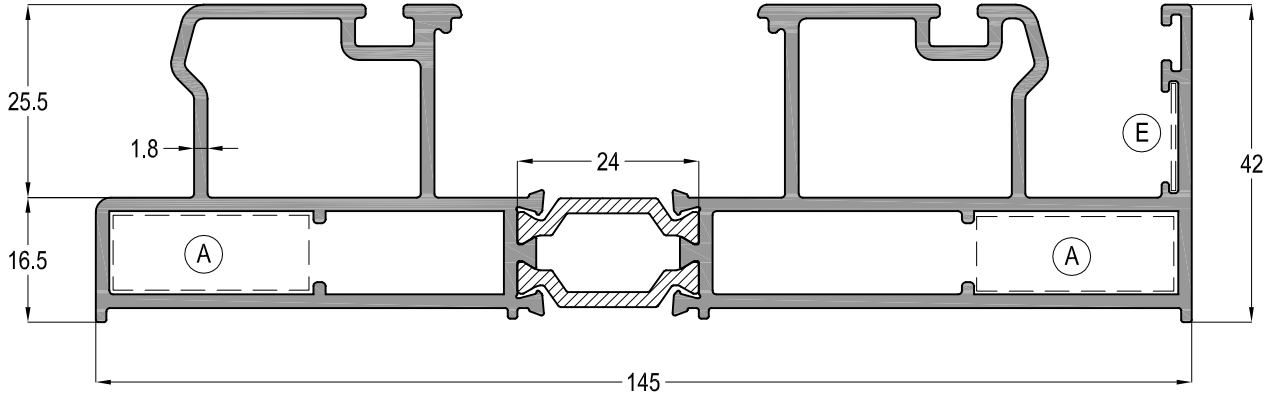

## LS60 02

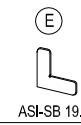
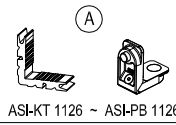

AĞIRLIK / Weight

2,810 kg/mt





# LS60 - 1,8mm

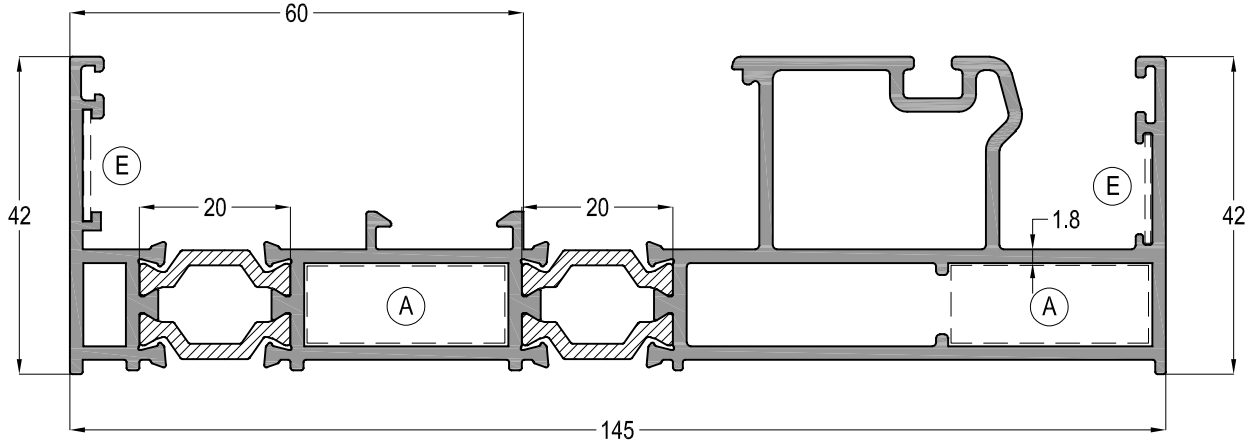

YALITIMLI KALDIR-SÜR SİSTEM  
THERMAL LIFT&SLIDE SYSTEM

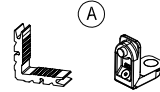

ASISTAL

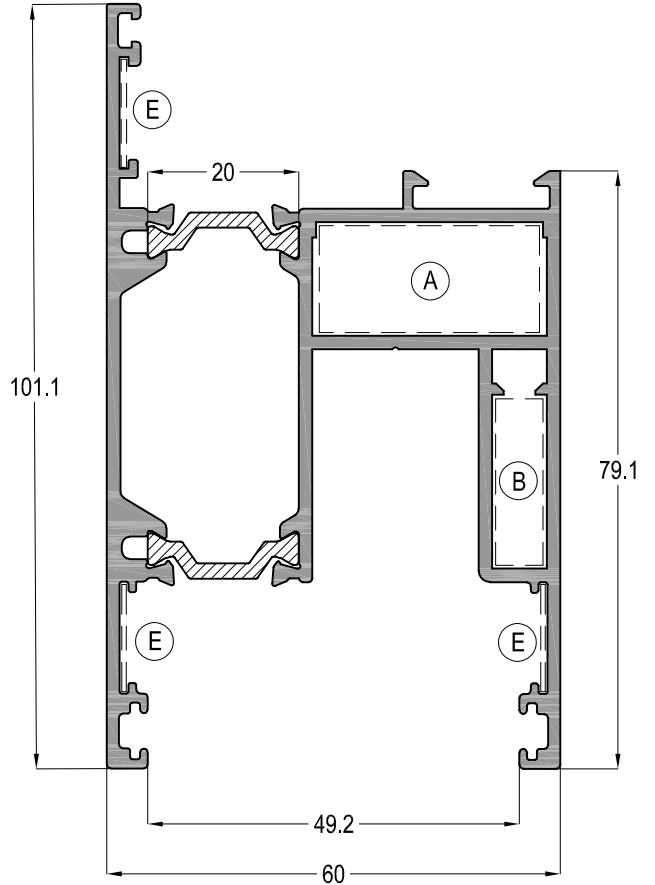
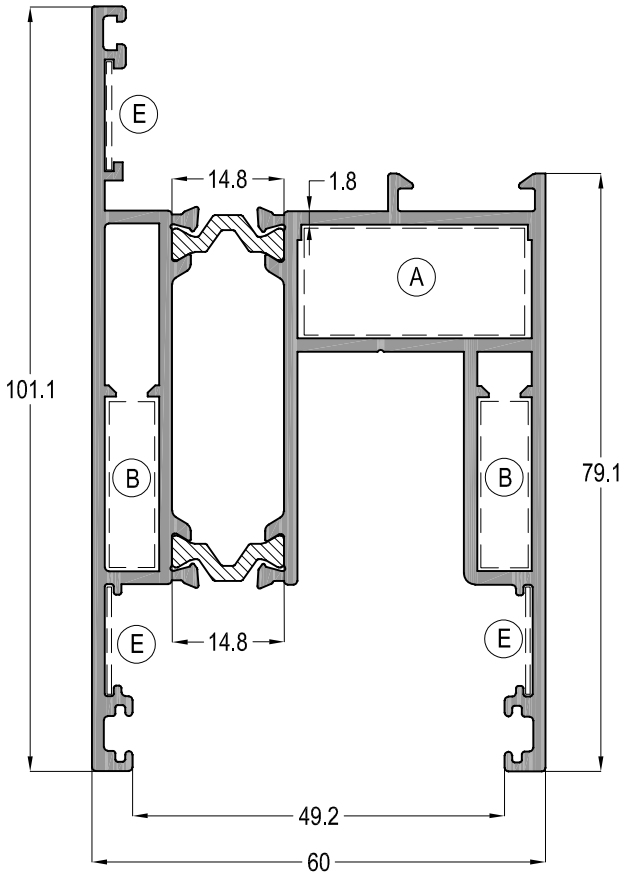

LS60 04		
		AĞIRLIK / Weight
ASI-KT 1126 ~ ASI-PB 1126	ASI-SB 19.1	2,749 kg/mt



LS60 11			Jx cm <sup>4</sup>	Jy cm <sup>4</sup>
			43,22	49,37
ASI-KT 1429	ASI-KT 2307	ASI-SB 19.1	AĞIRLIK / Weight	
			2,314 kg/mt	

LS60 12			
			AĞIRLIK / Weight
ASI-KT 1429	ASI-KT 2307	ASI-SB 19.1	2,183 kg/mt

❄ Sipariş öncesi kalıp bilgisi kontrol edilmeli / must be check profile mold before the order

Profil ağırlıklarımız teorik olup; teslim anındaki tartımız geçerlidir.

# LS60 - 1,8mm

YALITIMLI KALDIR-SÜR SİSTEM  
THERMAL LIFT&SLIDE SYSTEM

ASISTAL

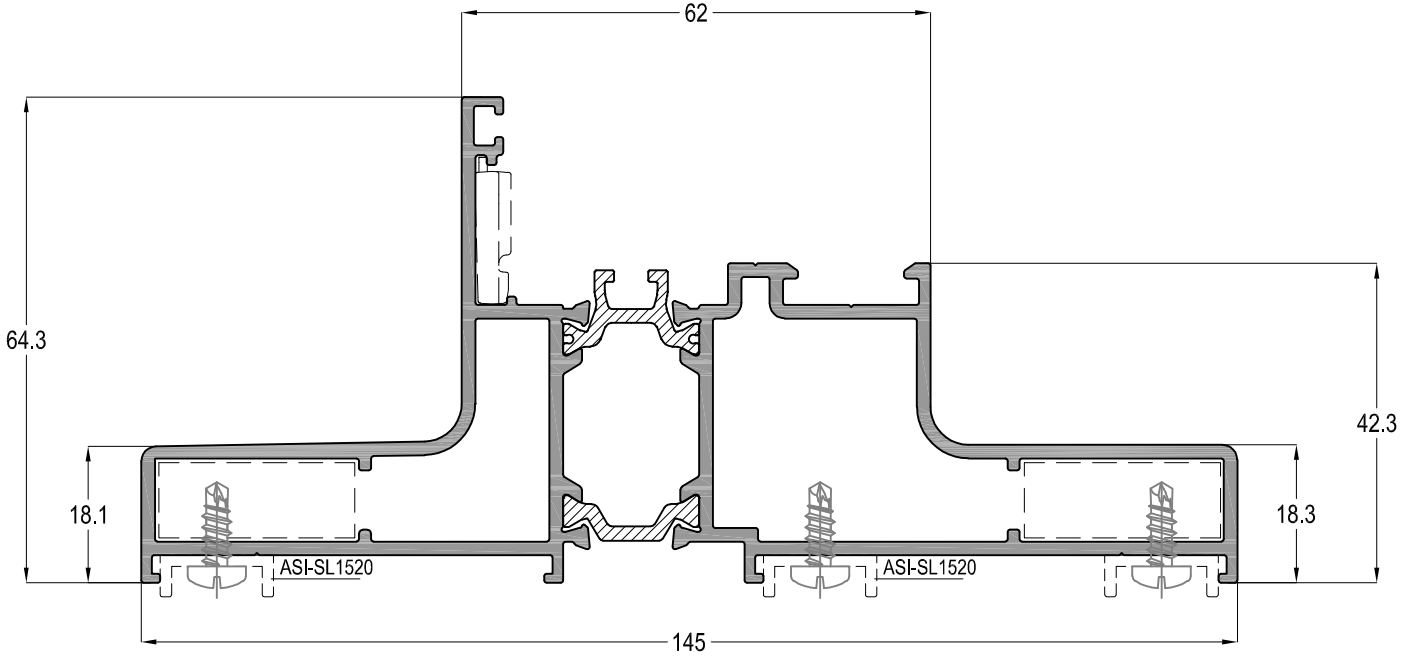

## LS60 62

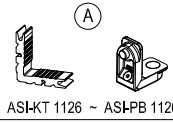

ASHKT 1126 - ASIPB 1126



ASIFUJI 2000

AĞIRLIK / Weight

2,423 kg/mt

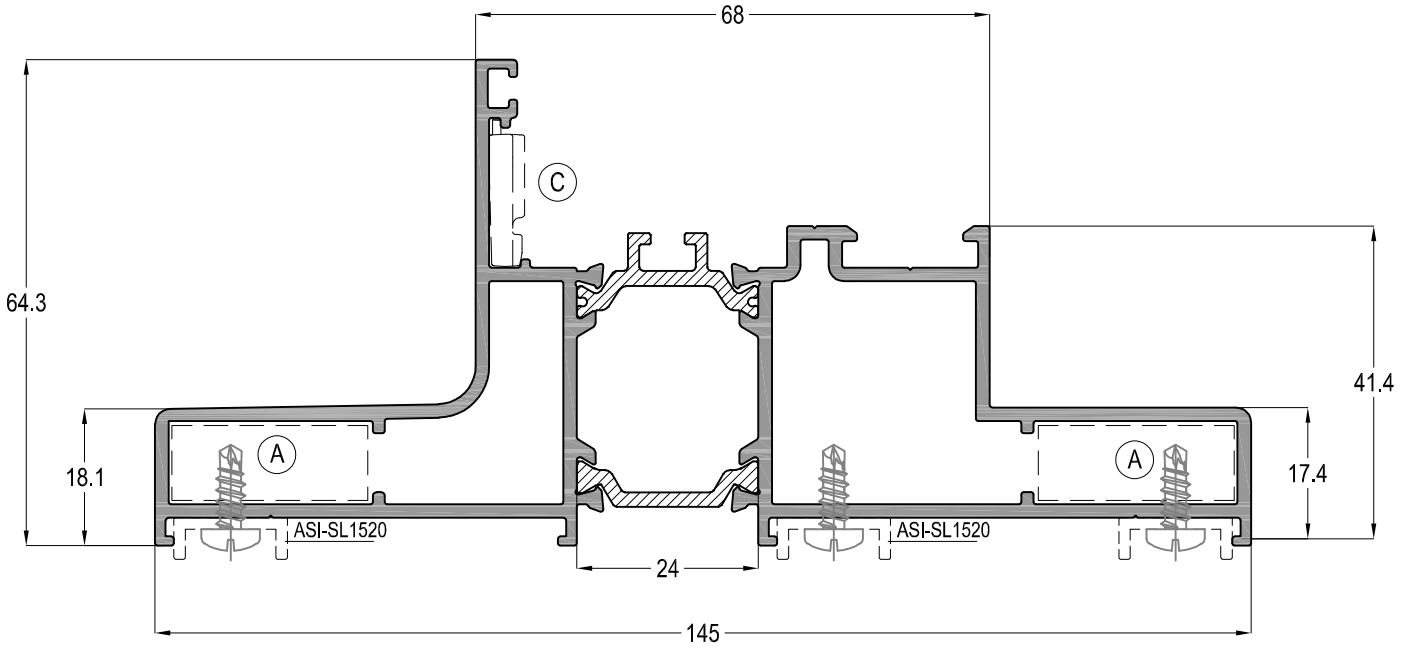

## LS60 68

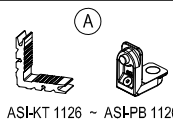

ASHKT 1126 - ASIPB 1126



ASIFUJI 2000

AĞIRLIK / Weight

2,411 kg/mt

⊗ Sipariş öncesi kalıp bilgisi kontrol edilmeli / must be check profile mold before the order

Profil ağırlıklarımız teorik olup; teslim anındaki tartımız geçerlidir.



# LS60 - 1,8mm

YALITIMLI KALDIR-SÜR SİSTEM  
THERMAL LIFT&SLIDE SYSTEM

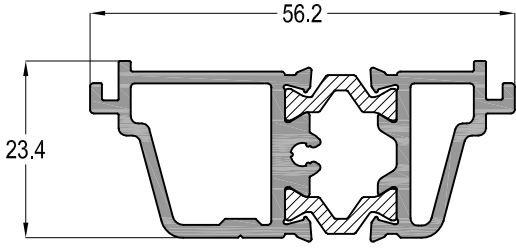

## LS60 41



MO60-12

AĞIRLIK / Weight

0,967 kg/mt

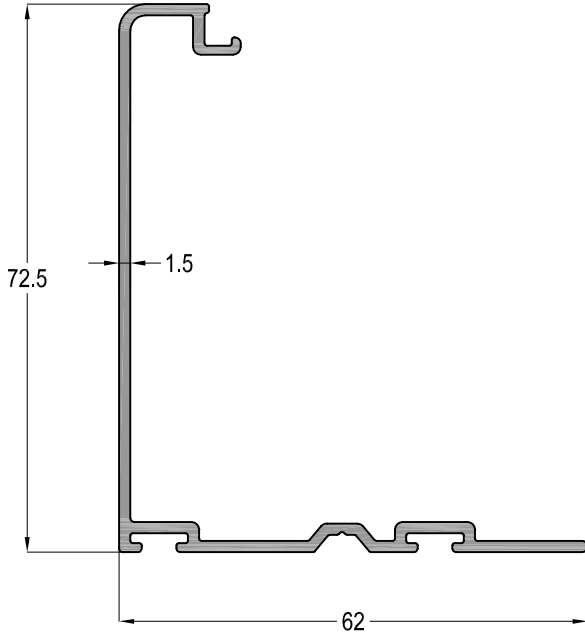

## LS60 42

AĞIRLIK / Weight

0,669 kg/mt

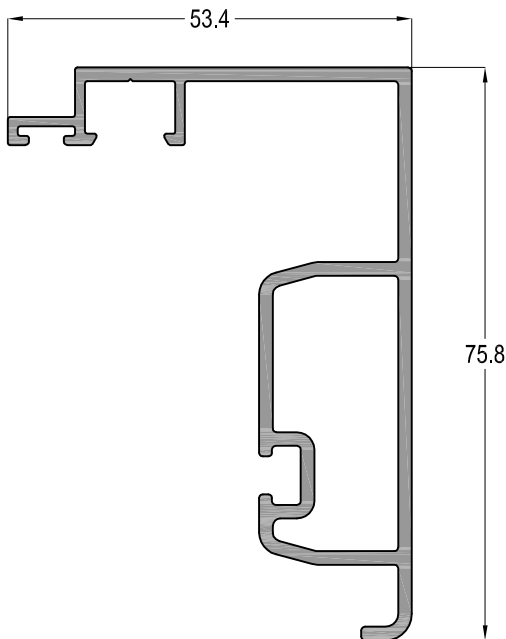

## LS60 43

AĞIRLIK / Weight

1,112 kg/mt

# LS60 - 1,8mm

YALITIMLI KALDIR-SÜR SİSTEM  
THERMAL LIFT&SLIDE SYSTEM



LS60 31	
	AĞIRLIK / Weight
	0,685 kg/mt

LS60 32	
	AĞIRLIK / Weight
	0,709 kg/mt

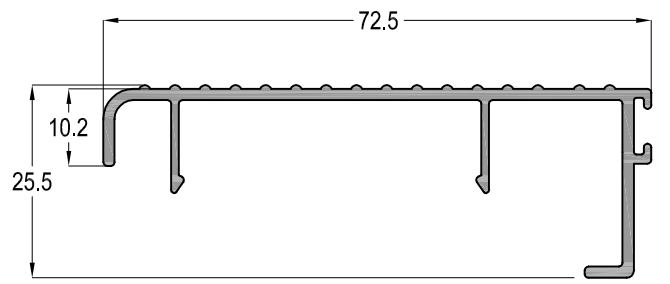
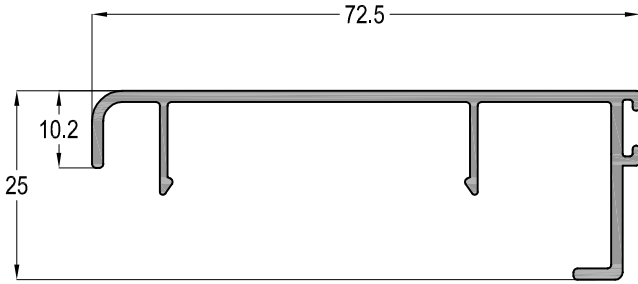
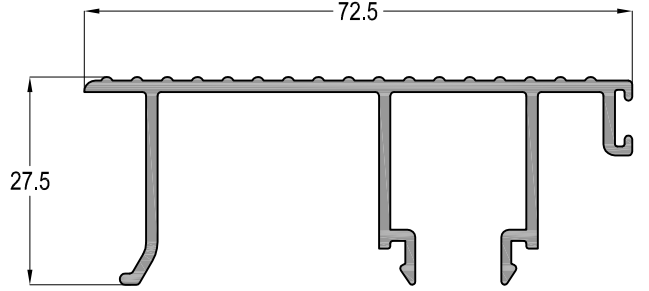
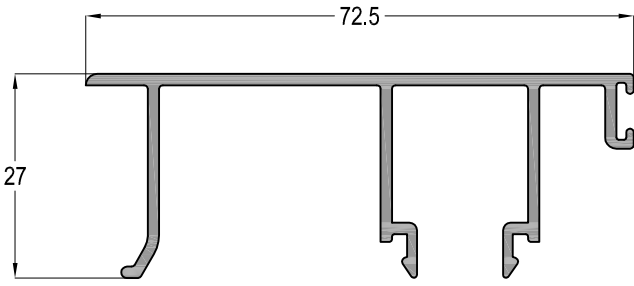

LS60 33	
	AĞIRLIK / Weight
	0,523 kg/mt

LS60 34	
	AĞIRLIK / Weight
	0,546 kg/mt

# LS60 - 1,8mm

YALITIMLI KALDIR-SÜR SİSTEM  
THERMAL LIFT&SLIDE SYSTEM



## LS60 71

 MO60-19	AĞIRLIK / Weight
	2,050 kg/mt

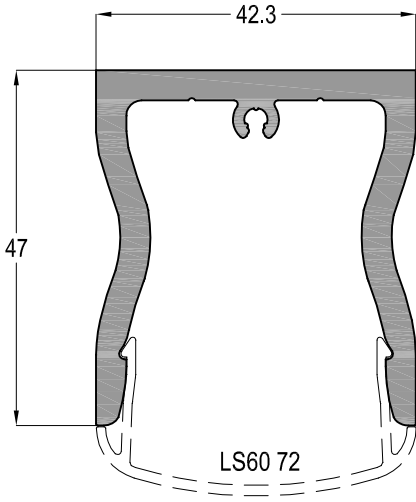

## LS60 72

	AĞIRLIK / Weight
	0,420 kg/mt

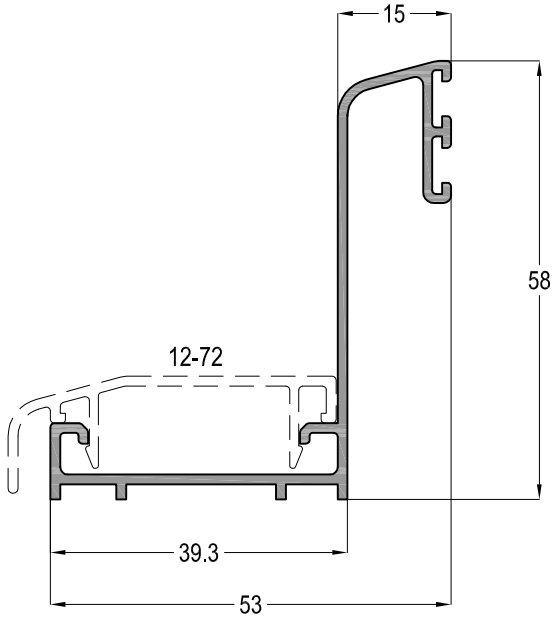
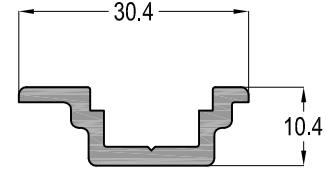
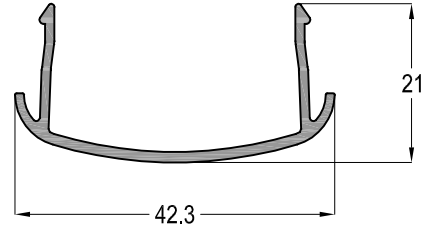

## LS60 44

	AĞIRLIK / Weight
	0,284 kg/mt

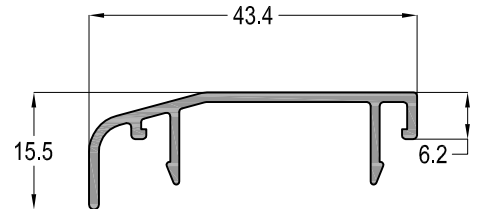

## 12-71

	AĞIRLIK / Weight
	0,545 kg/mt

## 12-72

	AĞIRLIK / Weight
	0,285 kg/mt

# LS60 - 1,8mm

YALITIMLI KALDIR-SÜR SİSTEM  
THERMAL LIFT&SLIDE SYSTEM

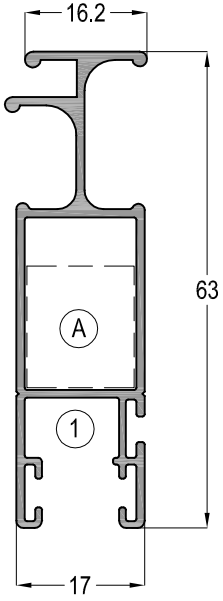

<b>15-306317-11</b>		
 ASI-BZ 5007	 ASI-BZ 5060	<b>AĞIRLIK / Weight</b>
		0,561 kg/mt

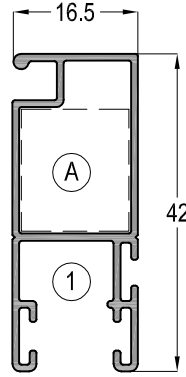

<b>15-304216-09</b>		
 ASI-BZ 5007	 ASI-BZ 5060	<b>AĞIRLIK / Weight</b>
		0,351 kg/mt

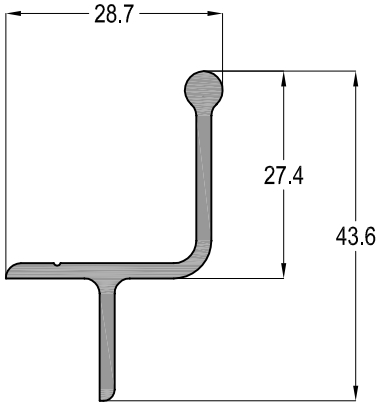

<b>LS60 61</b>
0,391 kg/mt

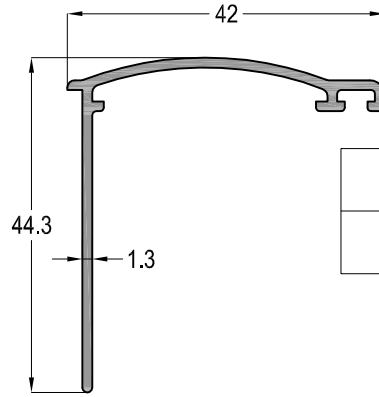

<b>12-54</b>
0,326 kg/mt

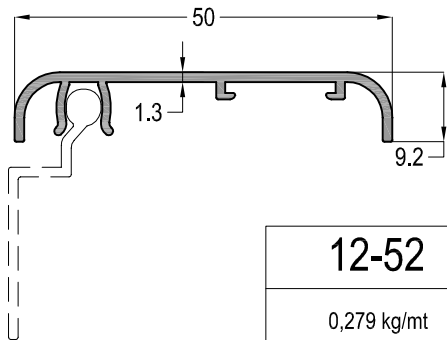

<b>12-52</b>
0,279 kg/mt

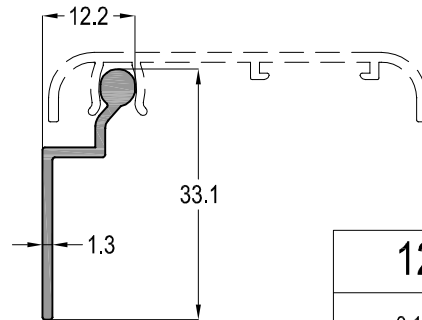

<b>12-53</b>
0,177 kg/mt

# LS60 - 1,8mm

YALITIMLI KALDIR-SÜR SİSTEM  
THERMAL LIFT&SLIDE SYSTEM

## ASISTAL

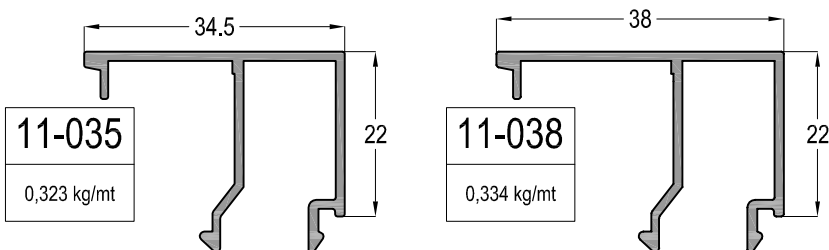
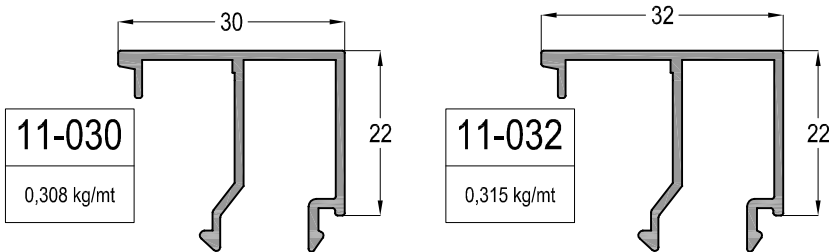
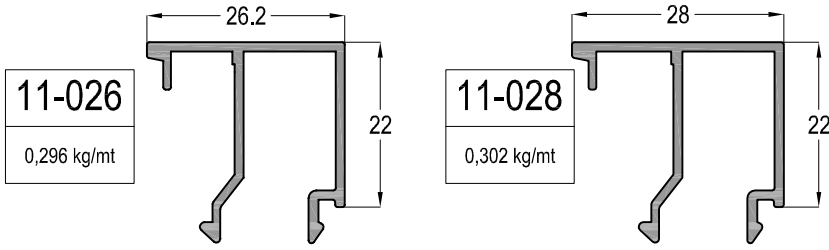
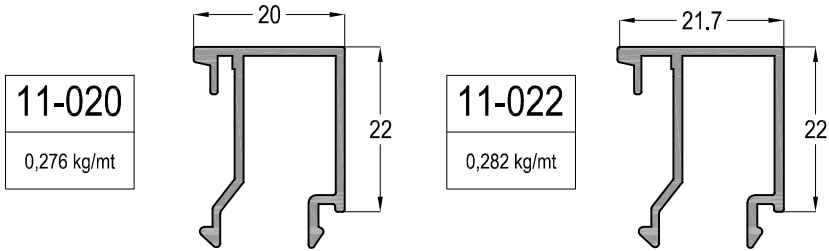
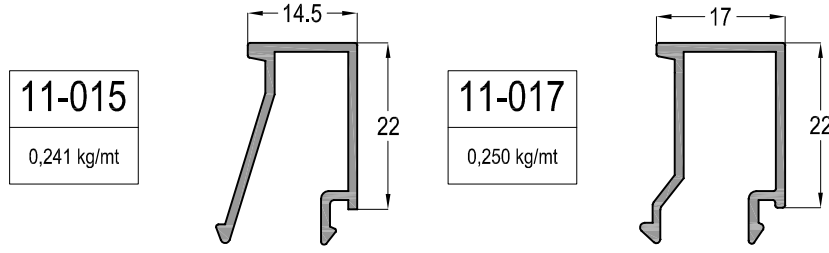
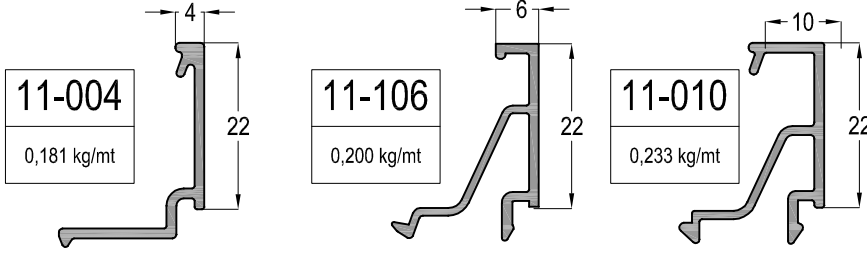

CAM KALINLIĞINA GÖRE CAM ÇİTASI SEÇİM TABLOSU  
Glazing Bead Selection Table according to the Glass Thickness

CAM KALINLIĞI Glass Thickness (mm)	CAM ÇİTASI Glazing Bead	İÇ CAM FİTİLİ Glass Gasket (IN)	DIŞ CAM FİTİLİ Glass Gasket (OUT)
10	11-038	EP2-03	EP1-01
11	11-038	EP2-02	EP1-01
12	11-038	EP2-01	EP1-01
13	11-035	EP2-03	EP1-01
14	11-035	EP2-02	EP1-01
15	11-035	EP2-01	EP1-01
16	11-032	EP2-03	EP1-01
17	11-032	EP2-02	EP1-01
18	11-030	EP2-03	EP1-01
19	11-030	EP2-02	EP1-01
20	11-028	EP2-03	EP1-01
21	11-028	EP2-02	EP1-01
22	11-026	EP2-03	EP1-01
23	11-026	EP2-02	EP1-01
24	11-026	EP2-01	EP1-01
25	11-022	EP2-03	EP1-01
26	11-022	EP2-02	EP1-01
28	11-020	EP2-03	EP1-01
29	11-020	EP2-02	EP1-01
30	11-020	EP2-01	EP1-01
31	11-017	EP2-03	EP1-01
32	11-017	EP2-02	EP1-01
33	11-017	EP2-01	EP1-01
34	11-015	EP2-02	EP1-01
35	11-015	EP2-01	EP1-01
38	11-010	EP2-03	EP1-01
39	11-010	EP2-02	EP1-01
40	11-010	EP2-01	EP1-01
42	11-106	EP2-03	EP1-01
43	11-106	EP2-02	EP1-01
44	11-106	EP2-01	EP1-01
45	11-004	EP2-02	EP1-01
46	11-004	EP2-01	EP1-01

AÇILIM TİPLERİ NORMAL SÜRME - OPENING TYPES NORMAL SLIDING

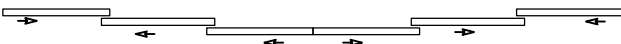
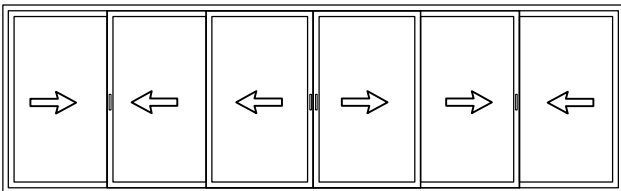
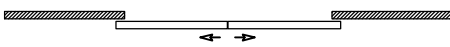
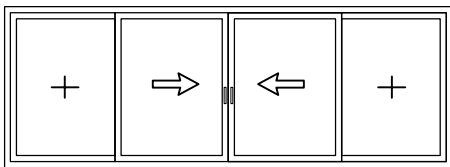
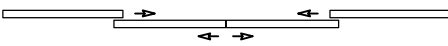
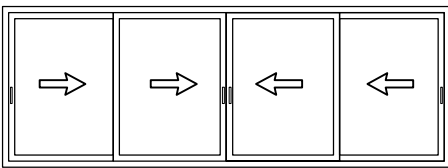
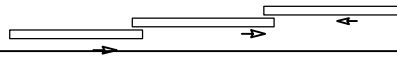
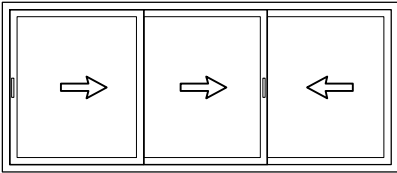
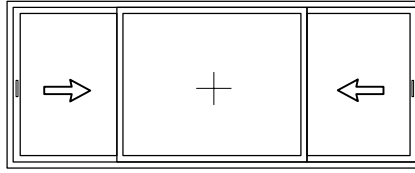
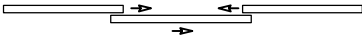
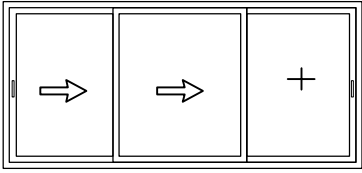
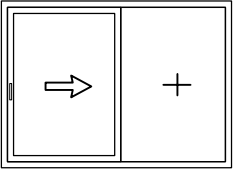
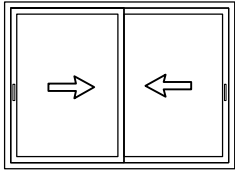



## AÇILIM TİPLERİ KALDIR-SÜR SÜRME - OPENING TYPES LIFT & SLIDING

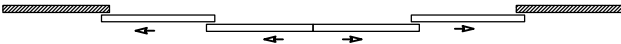
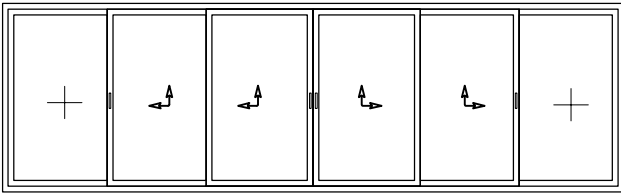
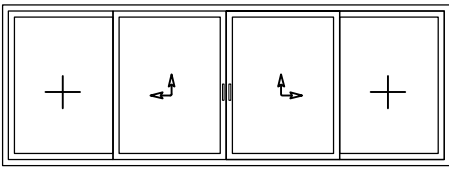
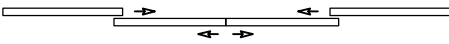
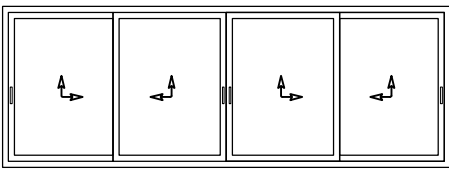
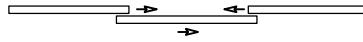
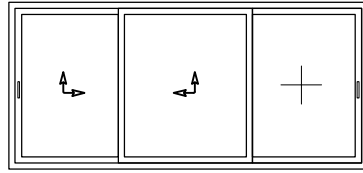
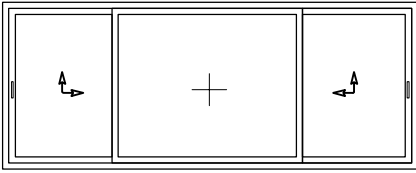
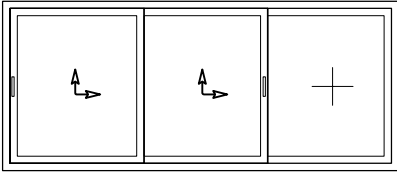
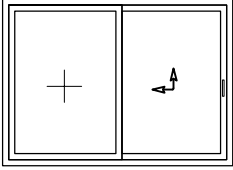
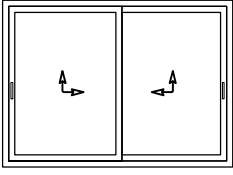



## RÜZGAR YÜKÜNE GÖRE MAKSİMUM KANAT EBATLARI MAXIMUM SASH DIMENSIONS FOR GIVEN WIND PRESSURE

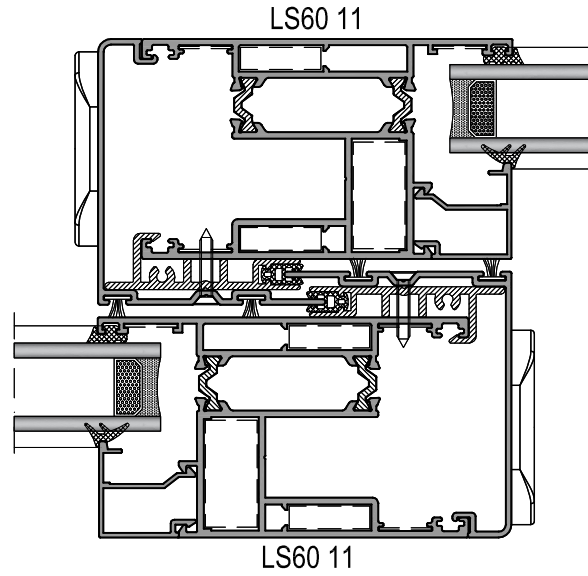
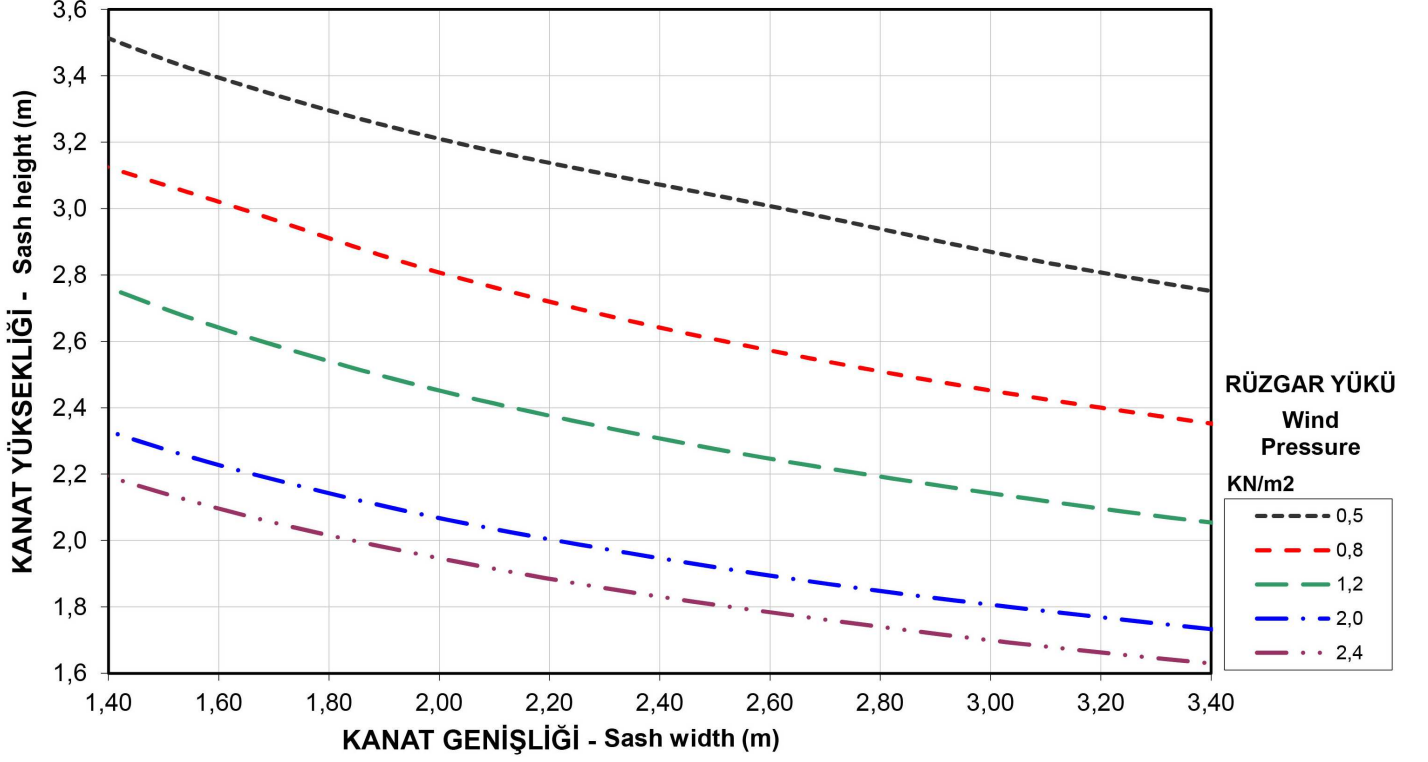

KANAT EBATLARI BELİRLENİRKEN MEKANİZMANIN TAŞIMA KAPASİTESİNİ GEÇMEMESİNE DİKKAT EDİLMELİDİR  
WHILE THE DETERMINE SASH DIMENSIONS, SASH WEIGHT MUST BE LESS THAN ROLLER CARY CAPACITY



### RÜZGAR YÜKÜNE GÖRE MAKSİMUM KANAT EBATLARI MAXIMUM SASH DIMENSIONS FOR GIVEN WIND PRESSURE

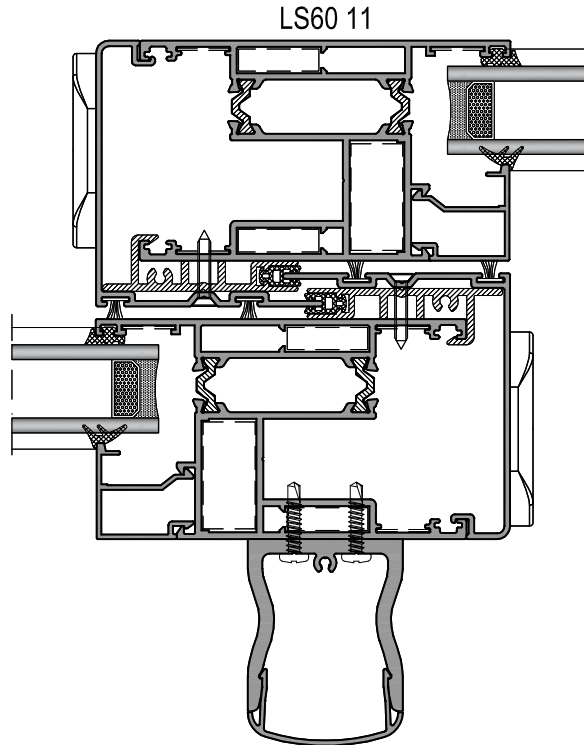
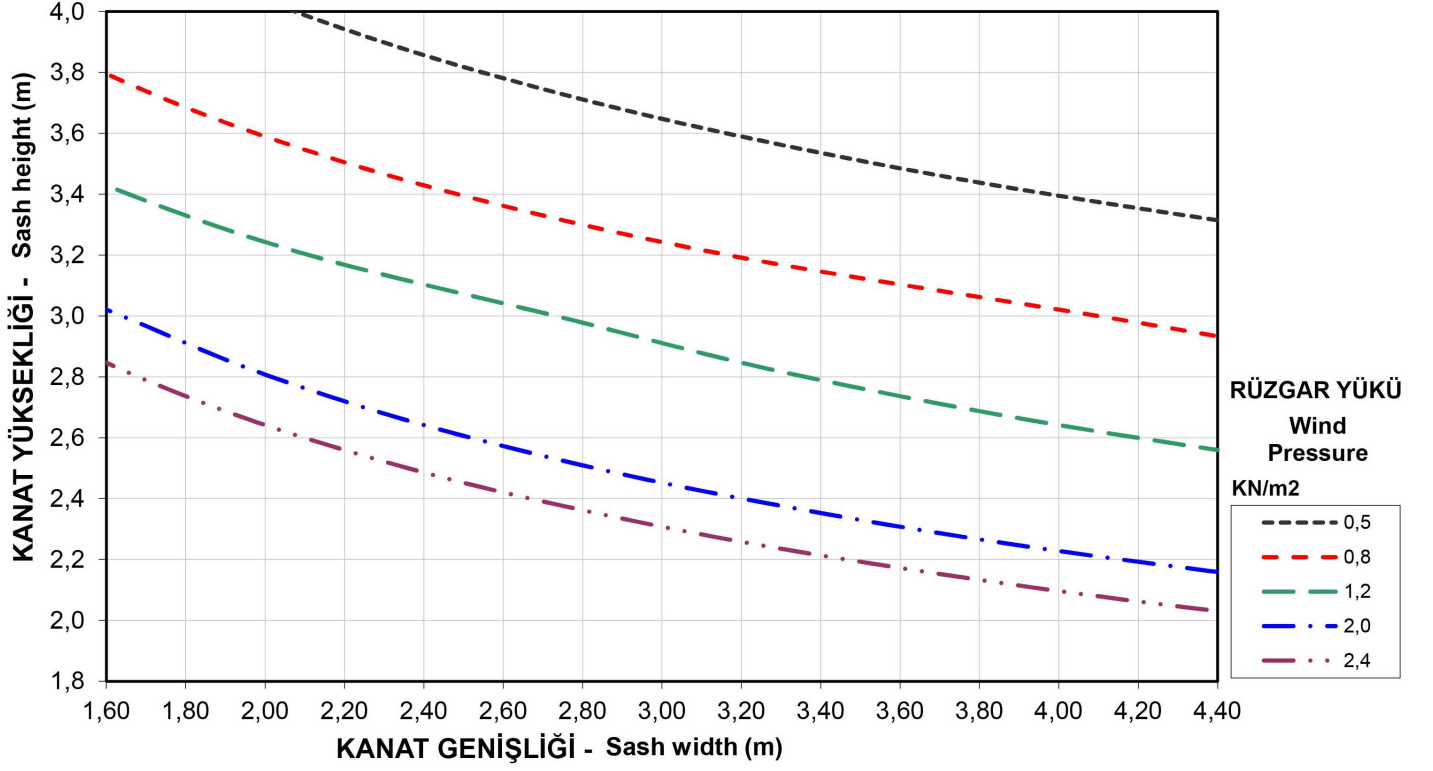

KANAT EBATLARI BELİRLENİRKEN MEKANİZMANIN TAŞIMA KAPASİTESİNİ GEÇMEMESİNE DİKKAT EDİLMELİDİR  
WHILE THE DETERMINE SASH DIMENSIONS, SASH WEIGHT MUST BE LESS THAN ROLLER CARY CAPACITY

**LS60 - 1,8mm**

YALITIMLI KALDIR-SÜR SİSTEMİ  
THERMAL LIFT&SLIDE SYSTEM

**ASISTAL**

**SİSTEM DETAYLARI**  
*SYSTEM DETAILS*



# LS60 - 1,8mm

YALITIMLI KALDIR-SÜR SİSTEM  
THERMAL LIFT&SLIDE SYSTEM

# ASISTAL

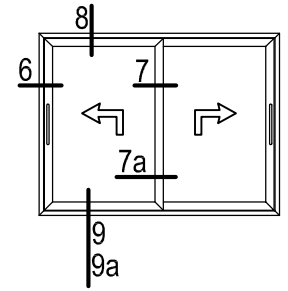

6

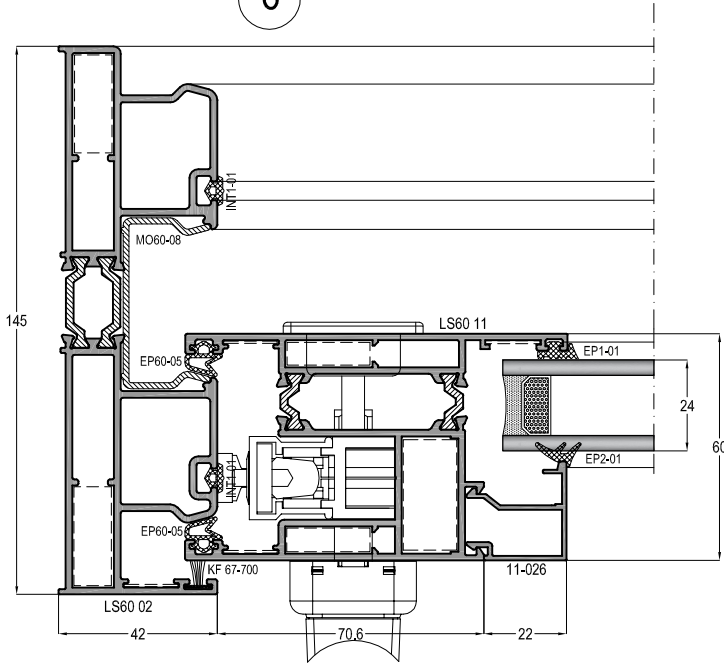

8

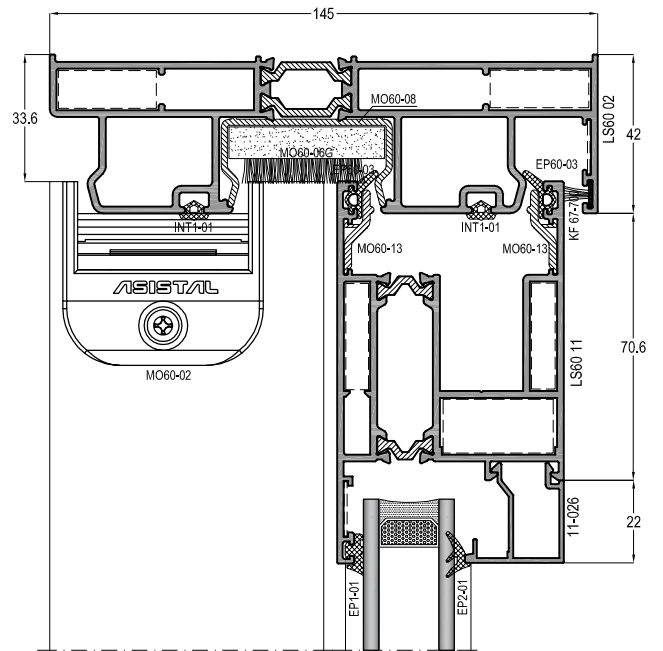

9a

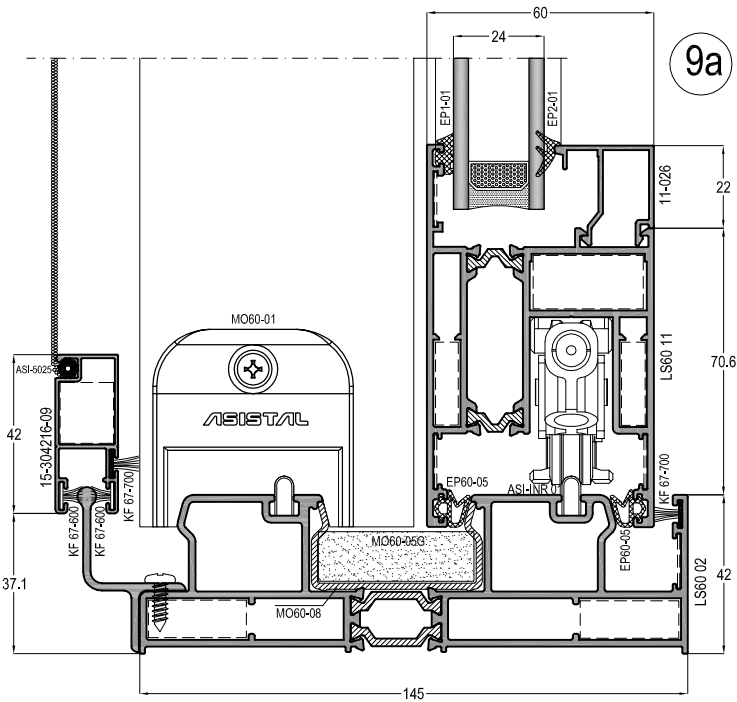

9

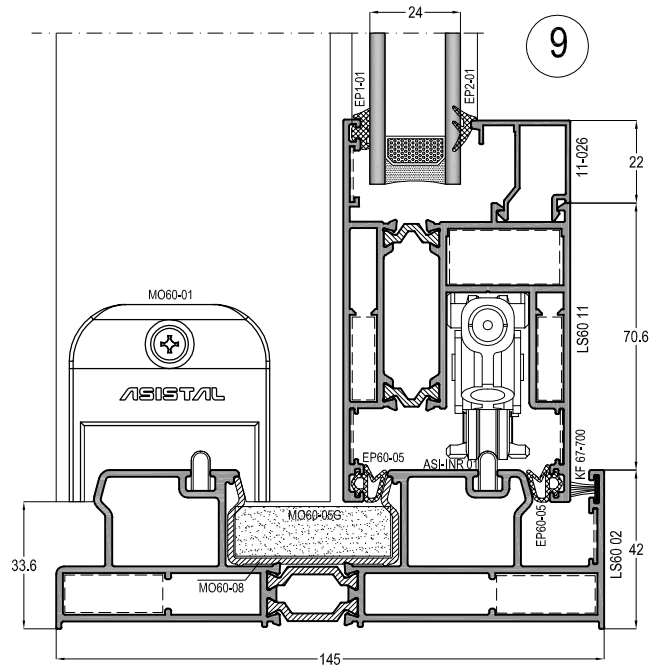

# LS60 - 1,8mm

YALITIMLI KALDIR-SÜR SİSTEM  
THERMAL LIFT&SLIDE SYSTEM

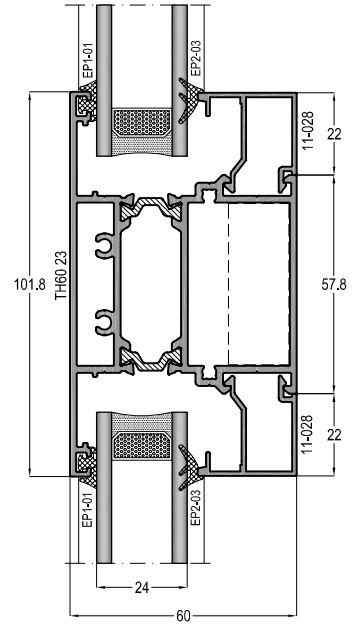
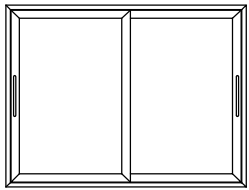
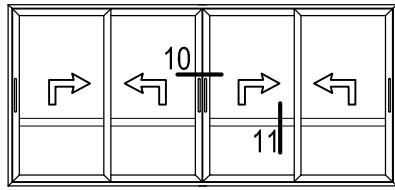
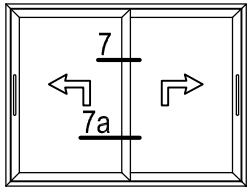

7

7a

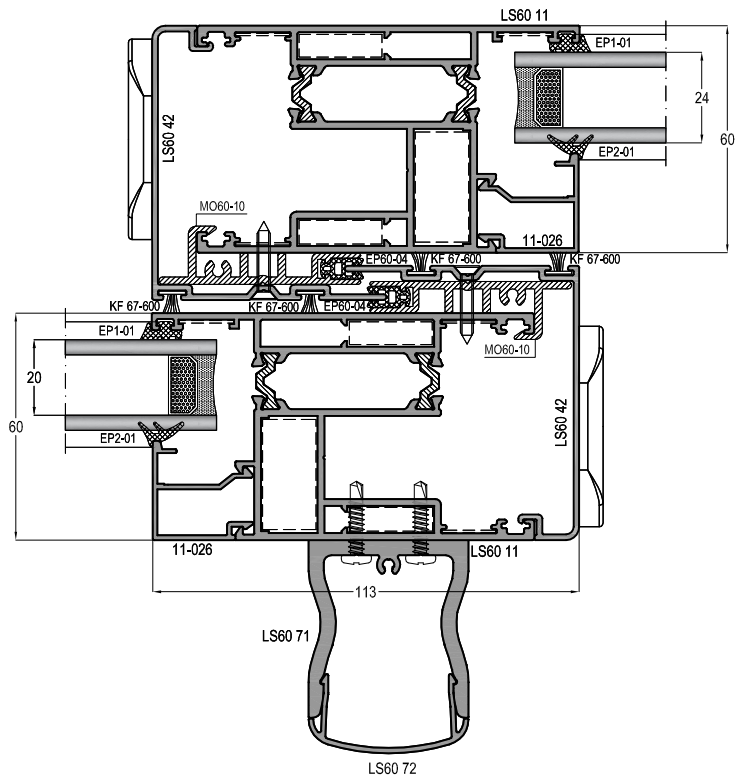
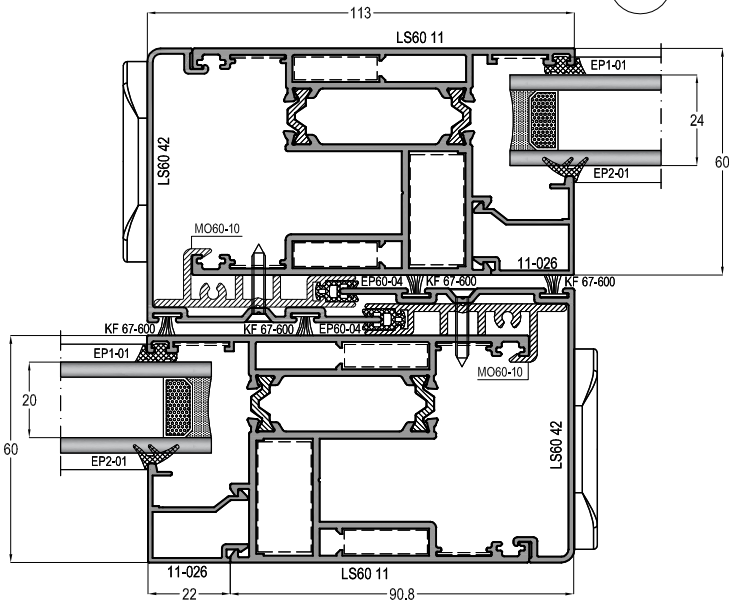

10

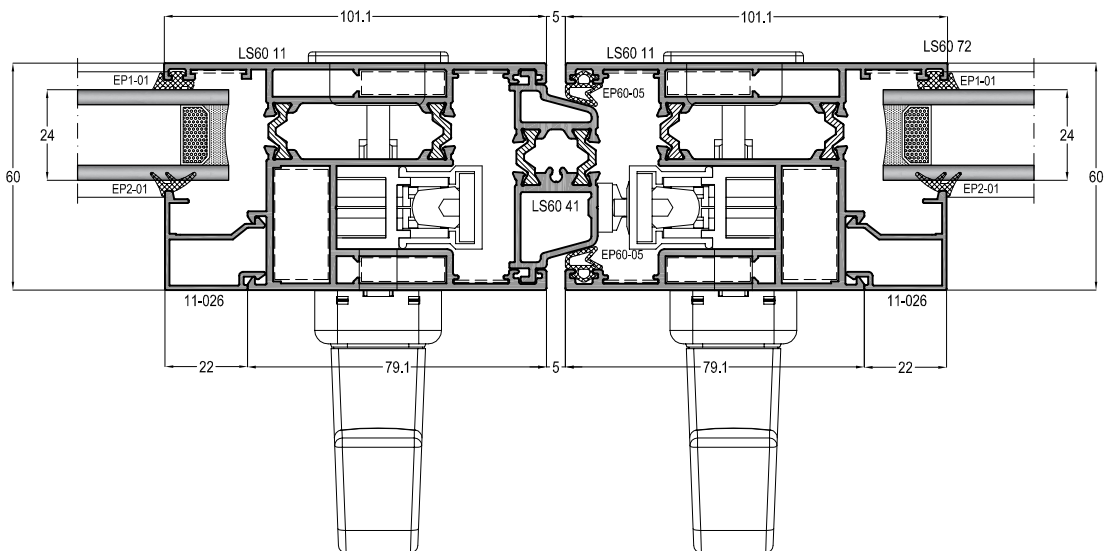

# LS60 - 1,8mm

YALITIMLI KALDIR-SÜR SİSTEM  
THERMAL LIFT&SLIDE SYSTEM

# ASISTAL

13

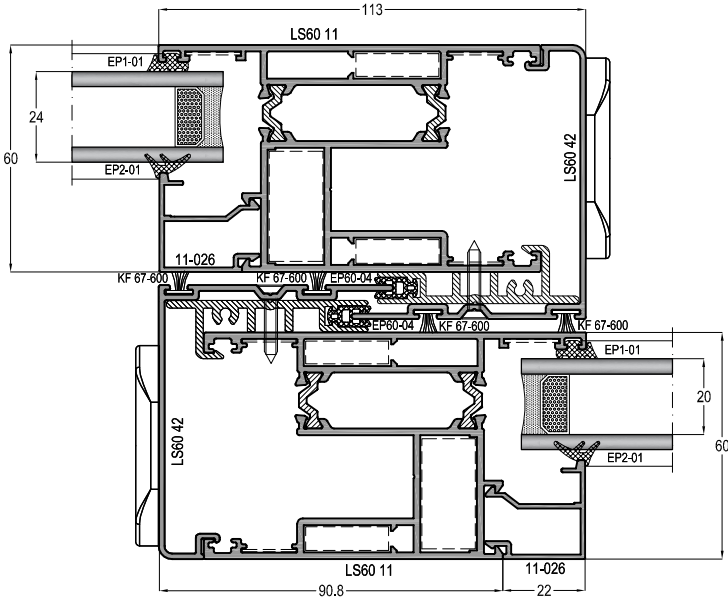

14

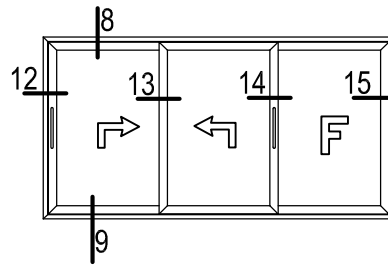
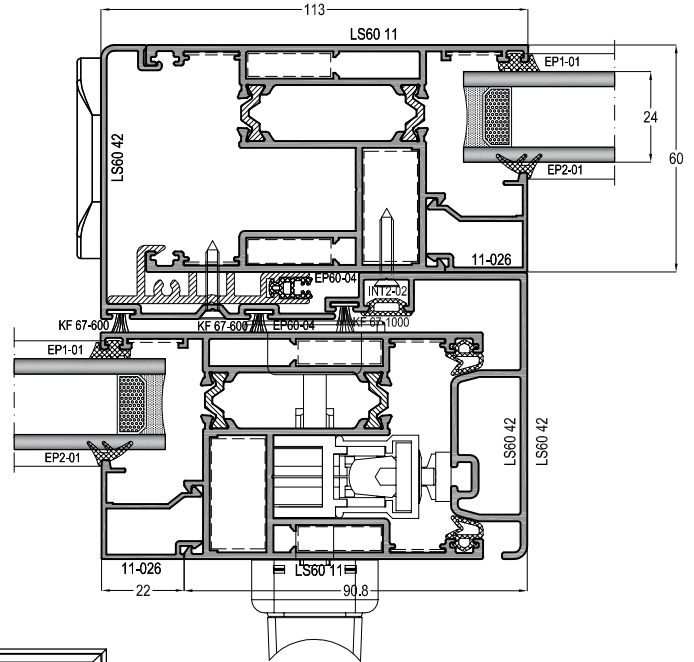

12

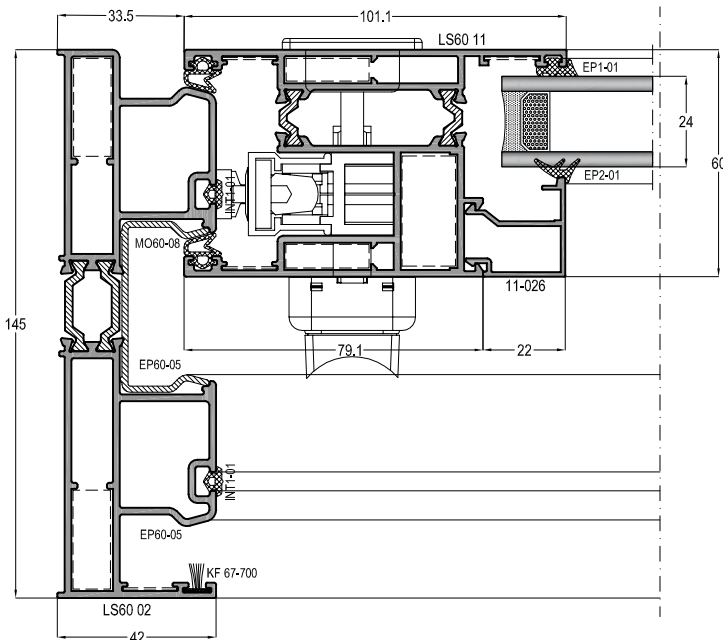

15

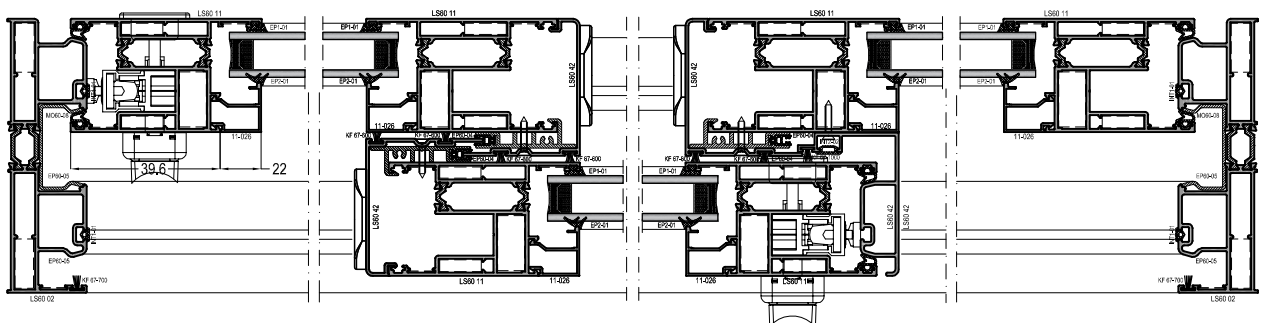
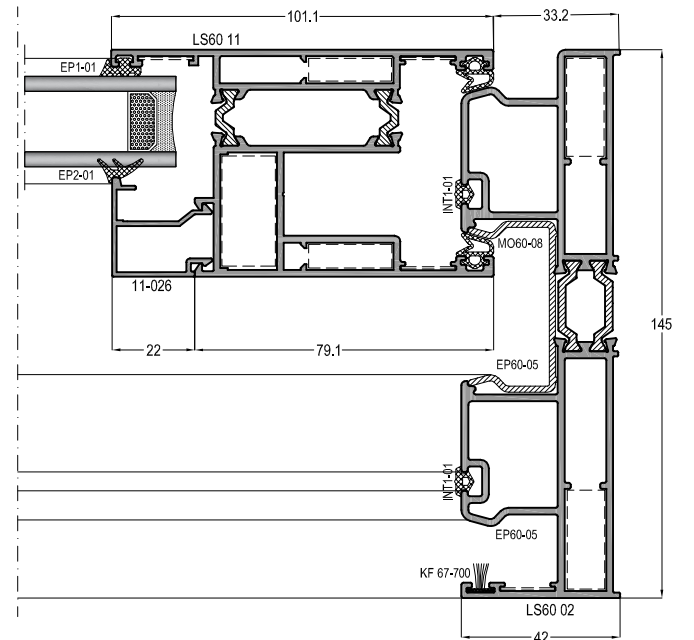

# LS60 - 1,8mm

YALITIMLI KALDIR-SÜR SİSTEM  
THERMAL LIFT&SLIDE SYSTEM

# ASİSTAL

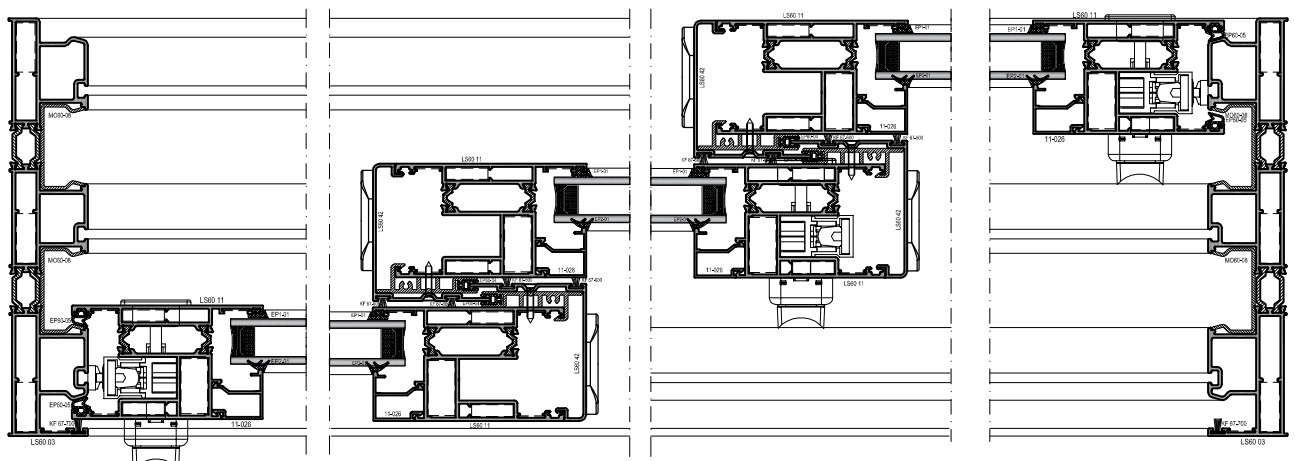
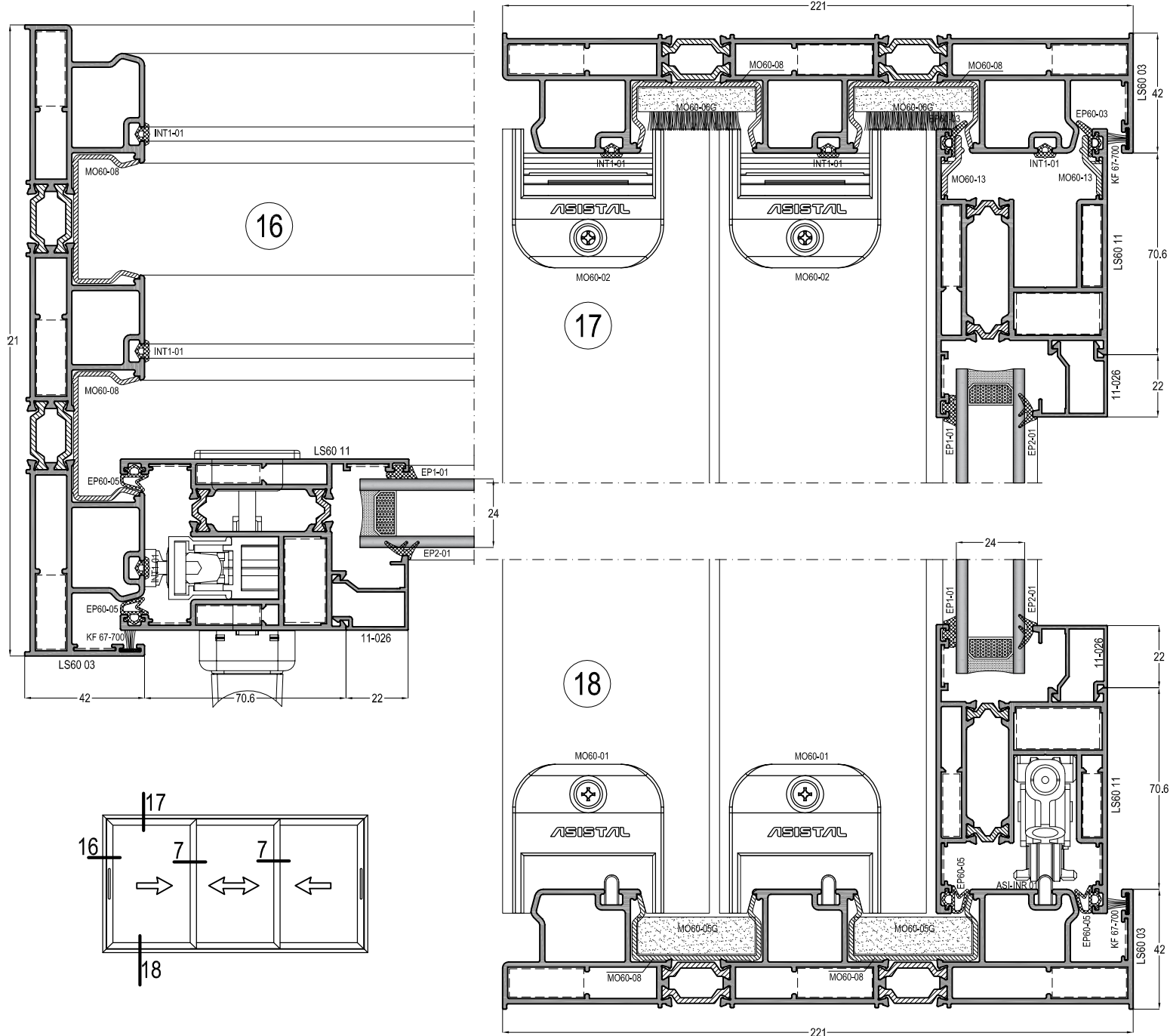



# LS60 - 1,8mm

YALITIMLI KALDIR-SÜR SİSTEM  
THERMAL LIFT&SLIDE SYSTEM

# ASISTAL

## HAREKETLİ KANATDAN SABİT YAPILMASI SLIDING SASH CONVERTING TO THE FIXED SASH

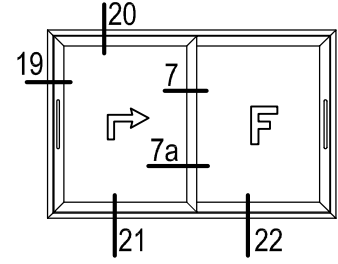

19

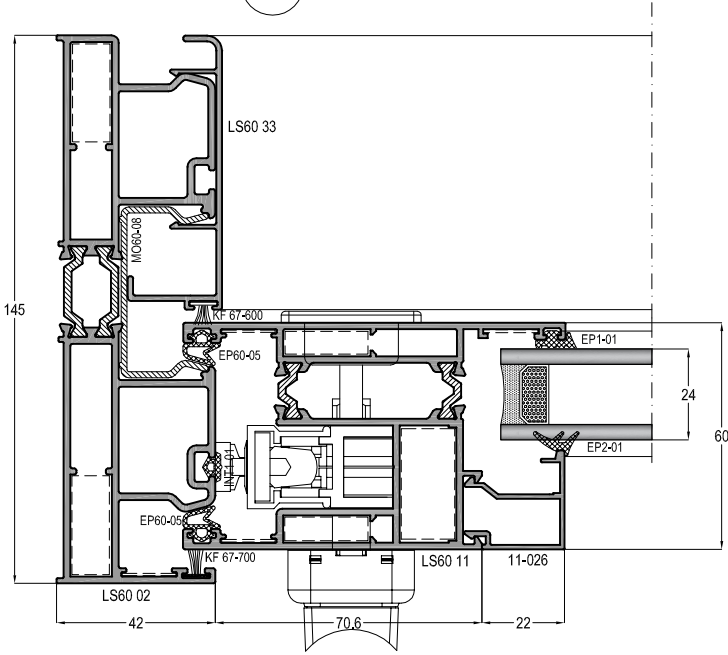

20

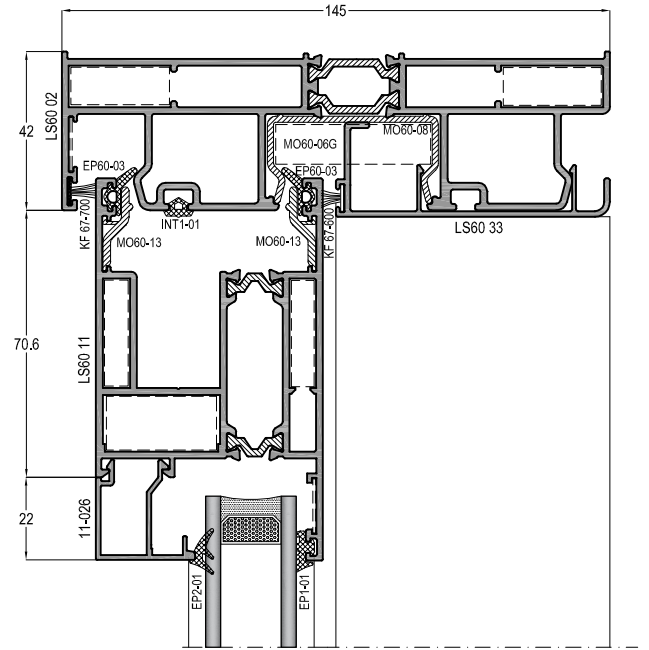

22

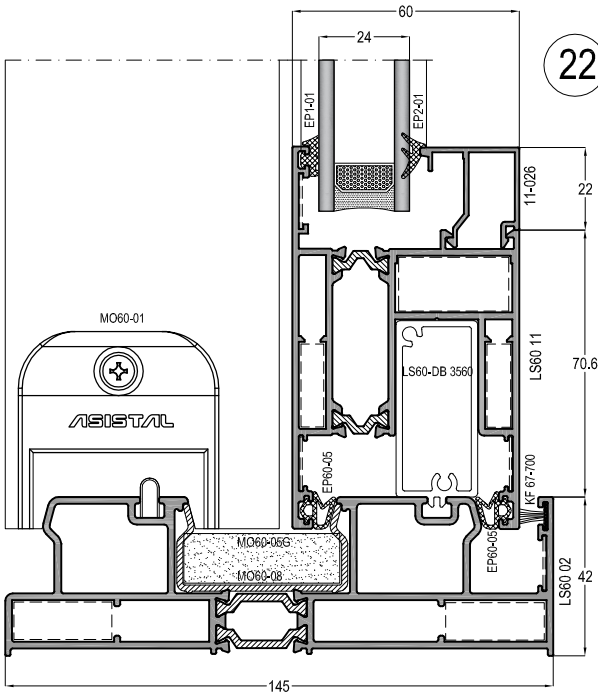

21

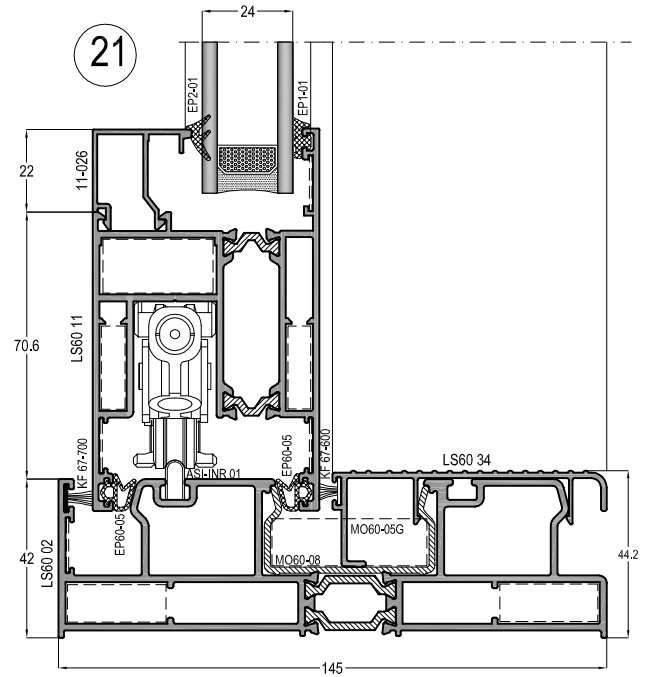



# LS60 - 1,8mm

YALITIMLI KALDIR-SÜR SİSTEM  
THERMAL LIFT&SLIDE SYSTEM

# ASISTAL

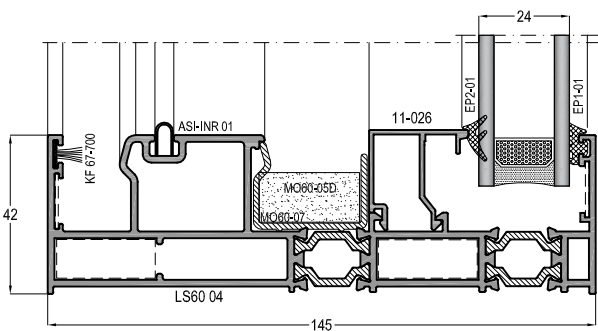
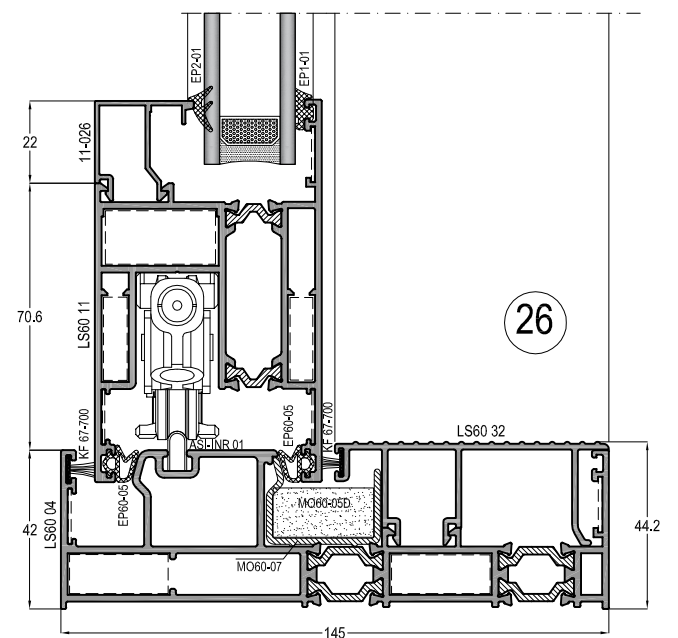
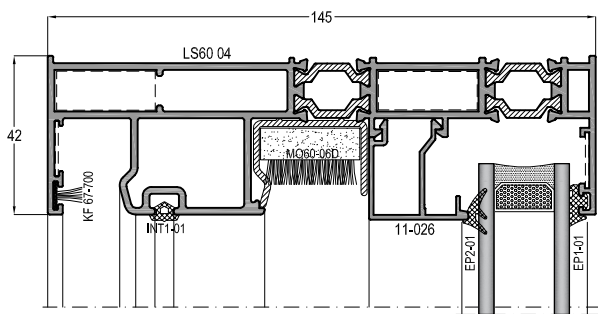
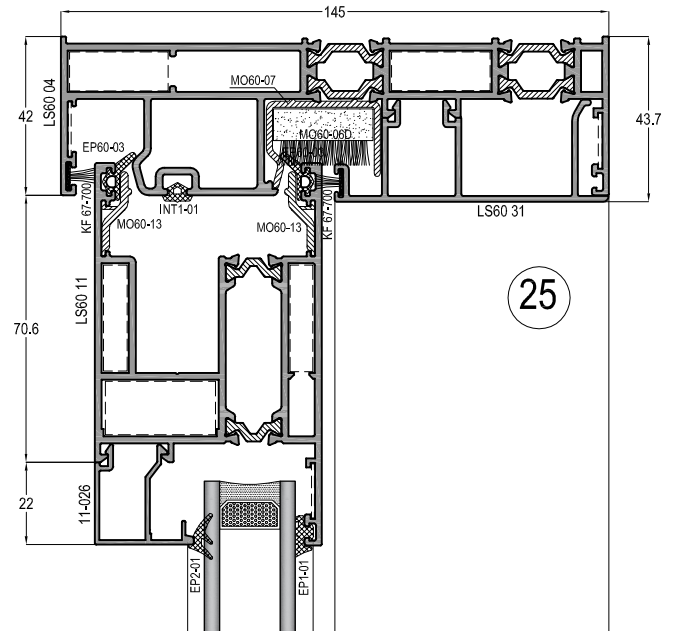
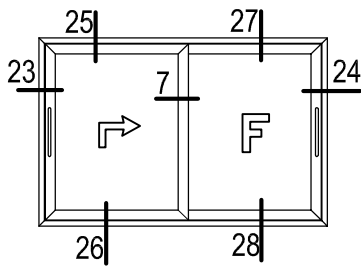
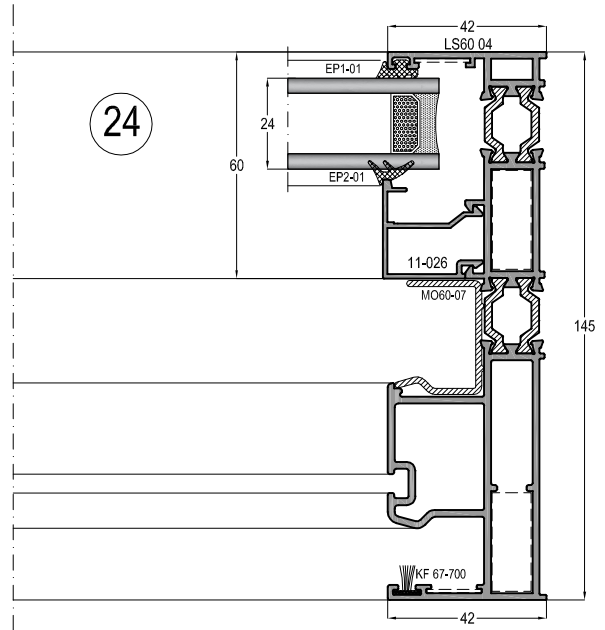
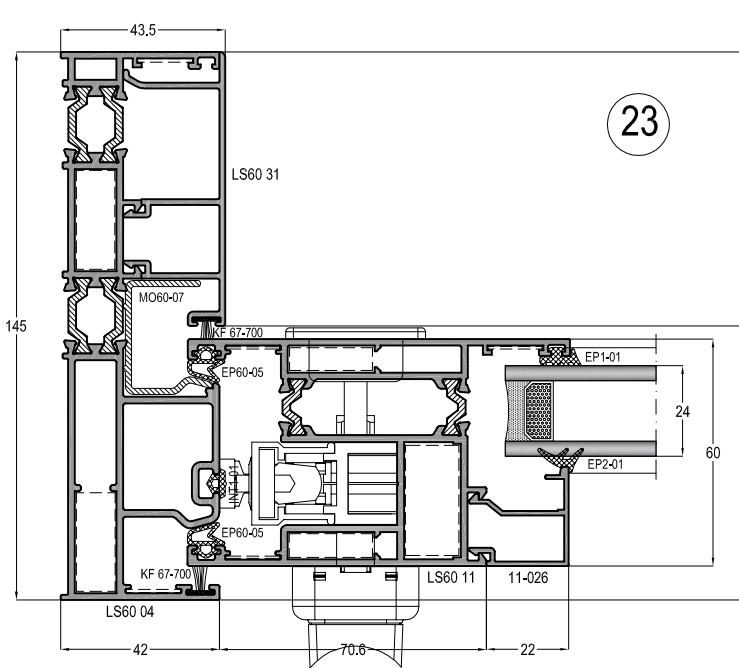

## TH62 S STEM GEÇ KASASI

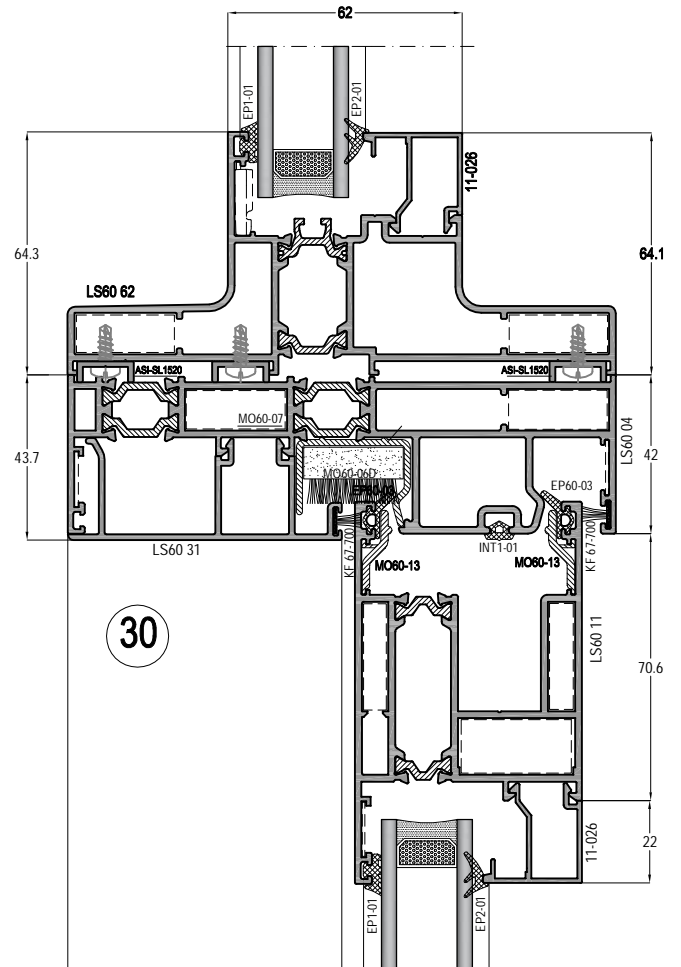
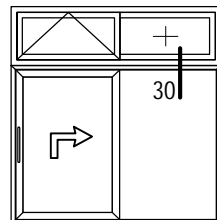
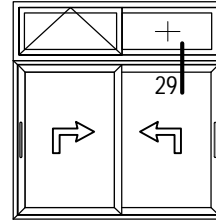
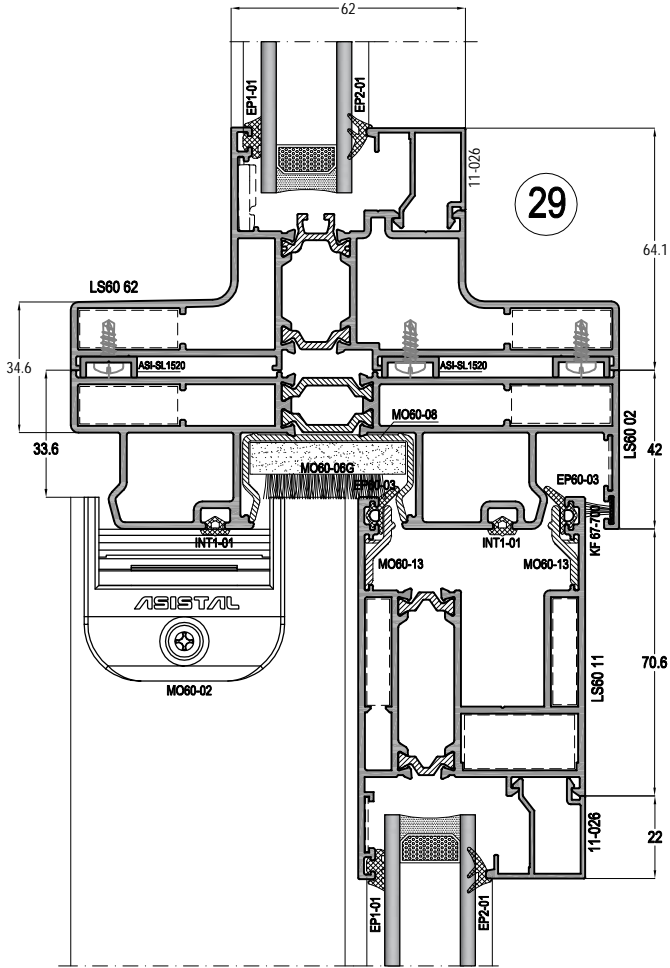

### NORMAL SÜRME SİSTEM DETAYI - LS60 N NORMAL SLIDING SYSTEM DETAILS

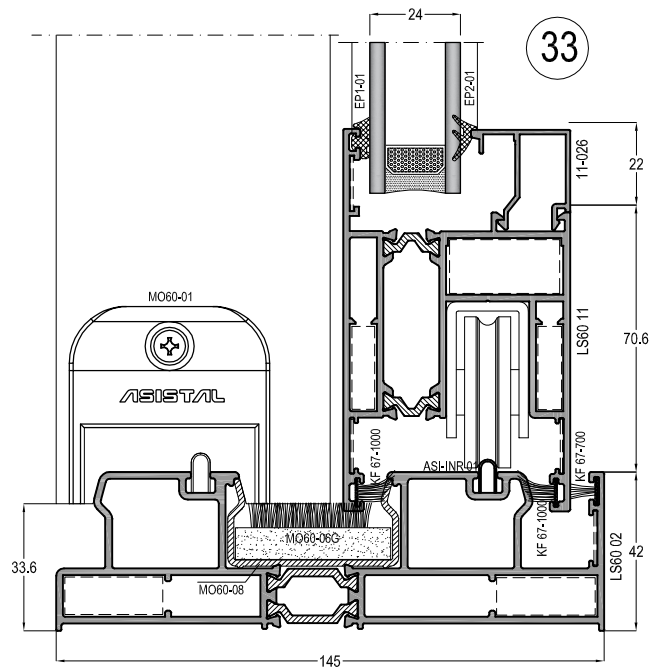
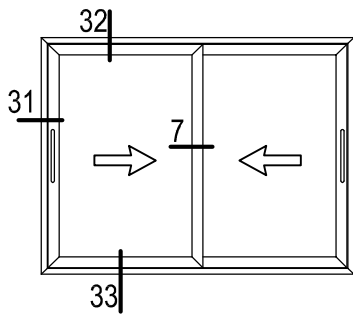
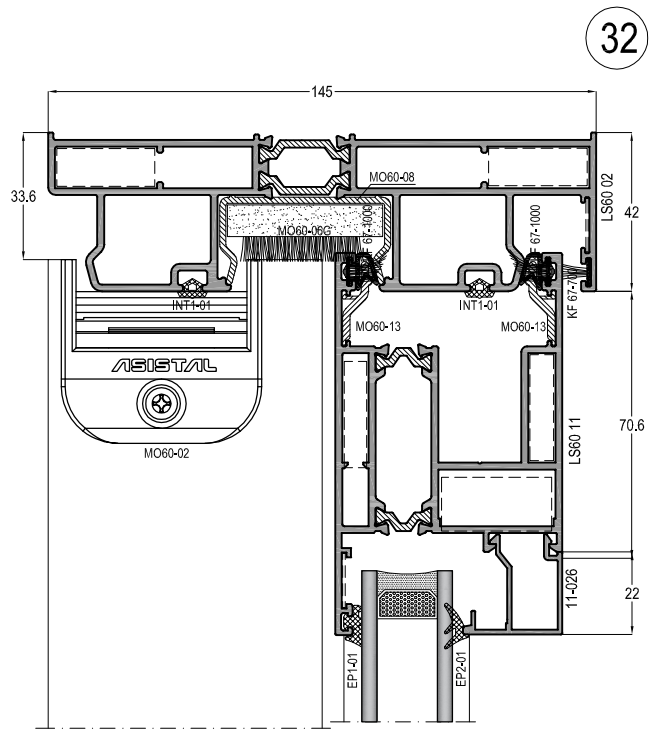
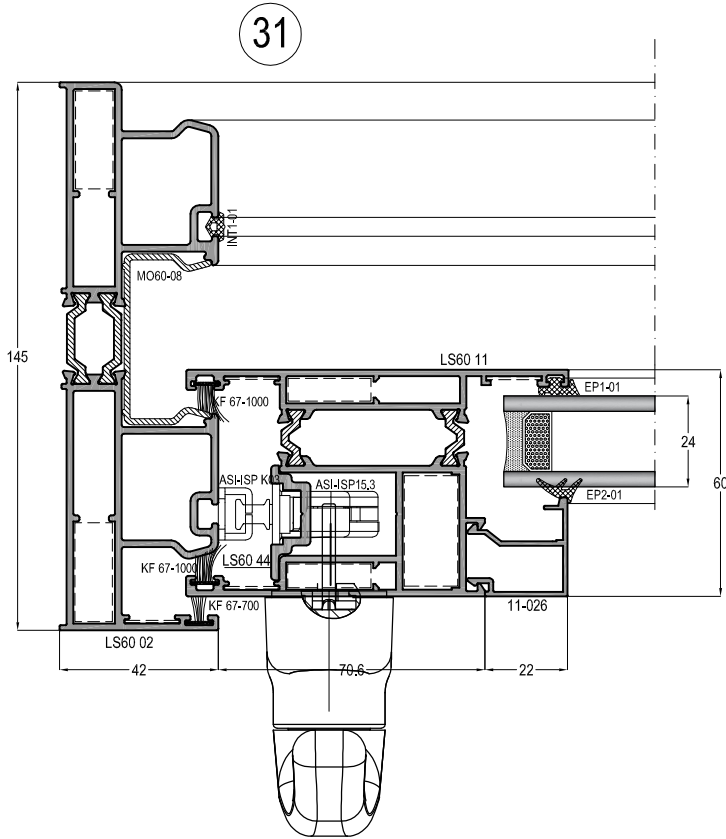

**LS60 - 1,8mm**

YALITIMLI KALDIR-SÜR SİSTEMİ  
THERMAL LIFT&SLIDE SYSTEM

**ASISTAL**

**KESİM VE MONTAJ ÇİZİMLERİ**  
*CUTTING & ASSEMBLY DRAWINGS*



## KALDIR-SÜR MEKANİZMASI MONTAJ ŞEMASI - LS60 MEK ve MEK2 İÇİN LIFT & SLIDING MECHANISM INSTALLATION FOR LS60 MEK1 & MEK2

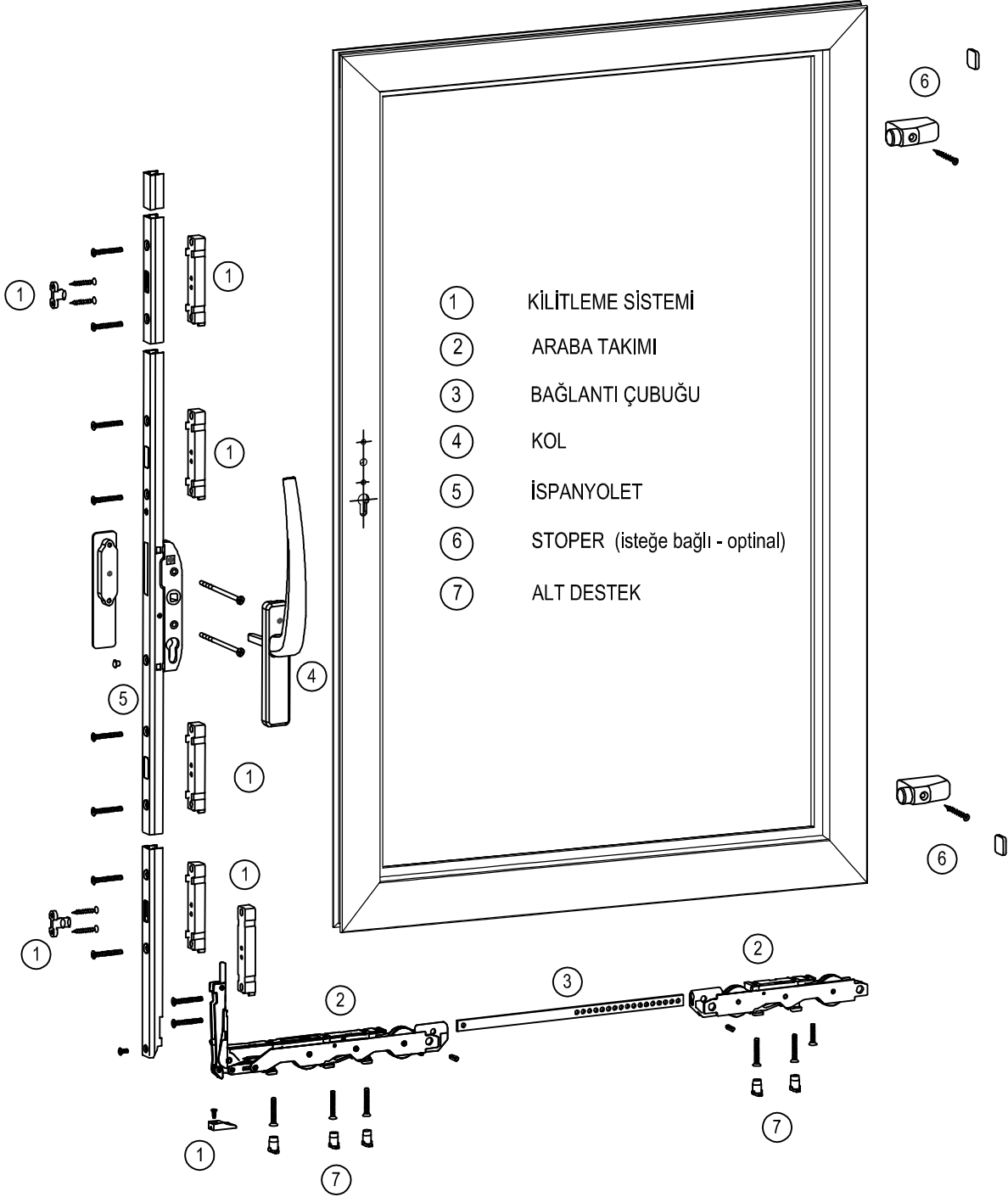

# LS60 - 1,8mm

YALITIMLI KALDIR-SÜR SİSTEM  
THERMAL LIFT&SLIDE SYSTEM



## KANAT - KASA KÖŞE BAĞLANTI MONTAJI ASSEMBLY FOR FRAME & SASH

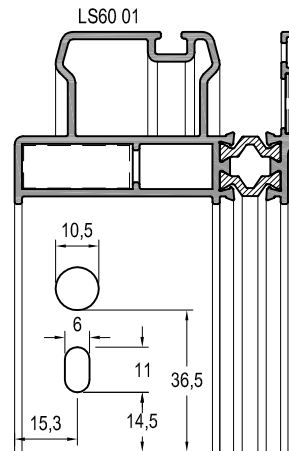
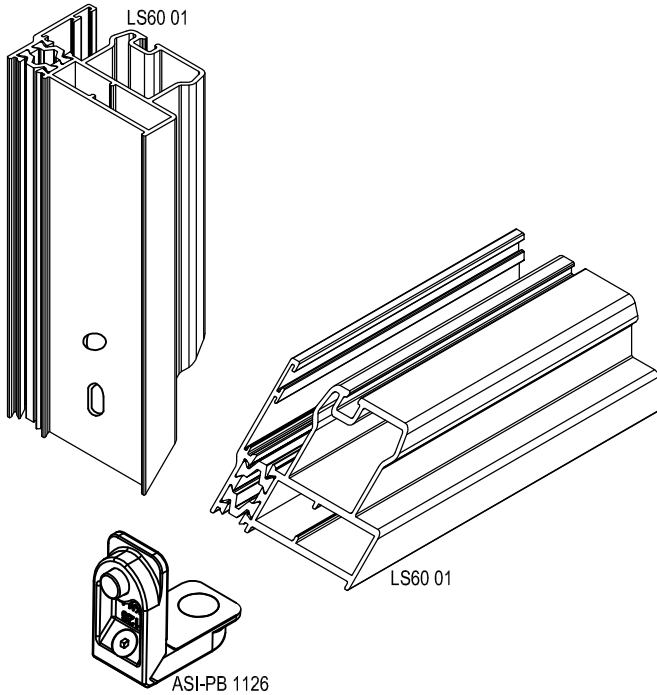
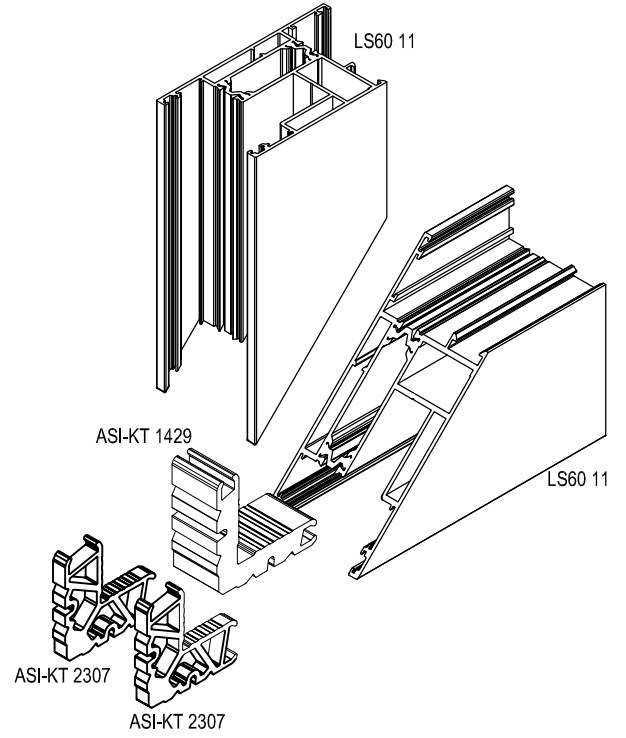
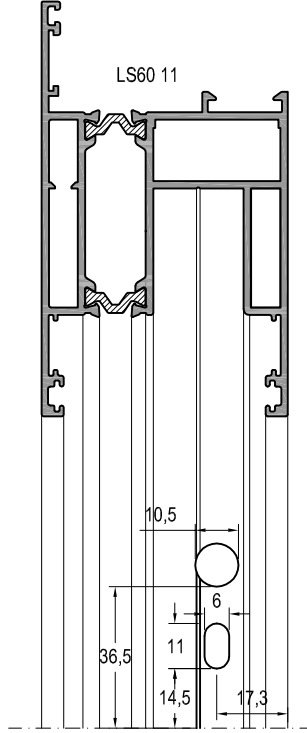

# LS60 - 1,8mm

YALITIMLI KALDIR-SÜR SİSTEM  
THERMAL LIFT&SLIDE SYSTEM



## KENET BAĞLANTI MONTAJI ASSEMBLY FOR CENTRAL LOCKING

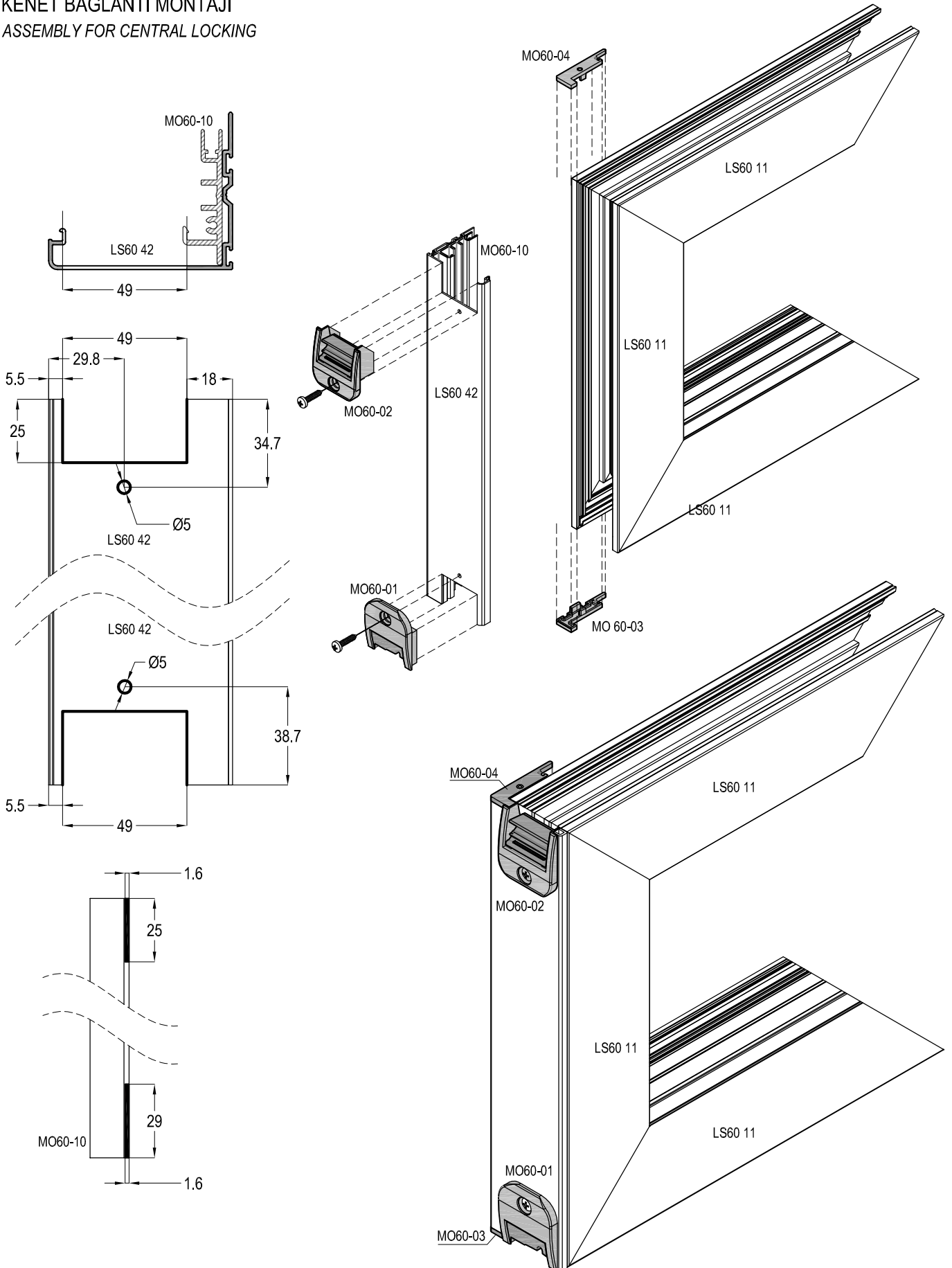

## TAKVIYE KOL BAĞLANTI MONTAJI ASSEMBLY FOR SUPPORTED HANDLE PROFILE

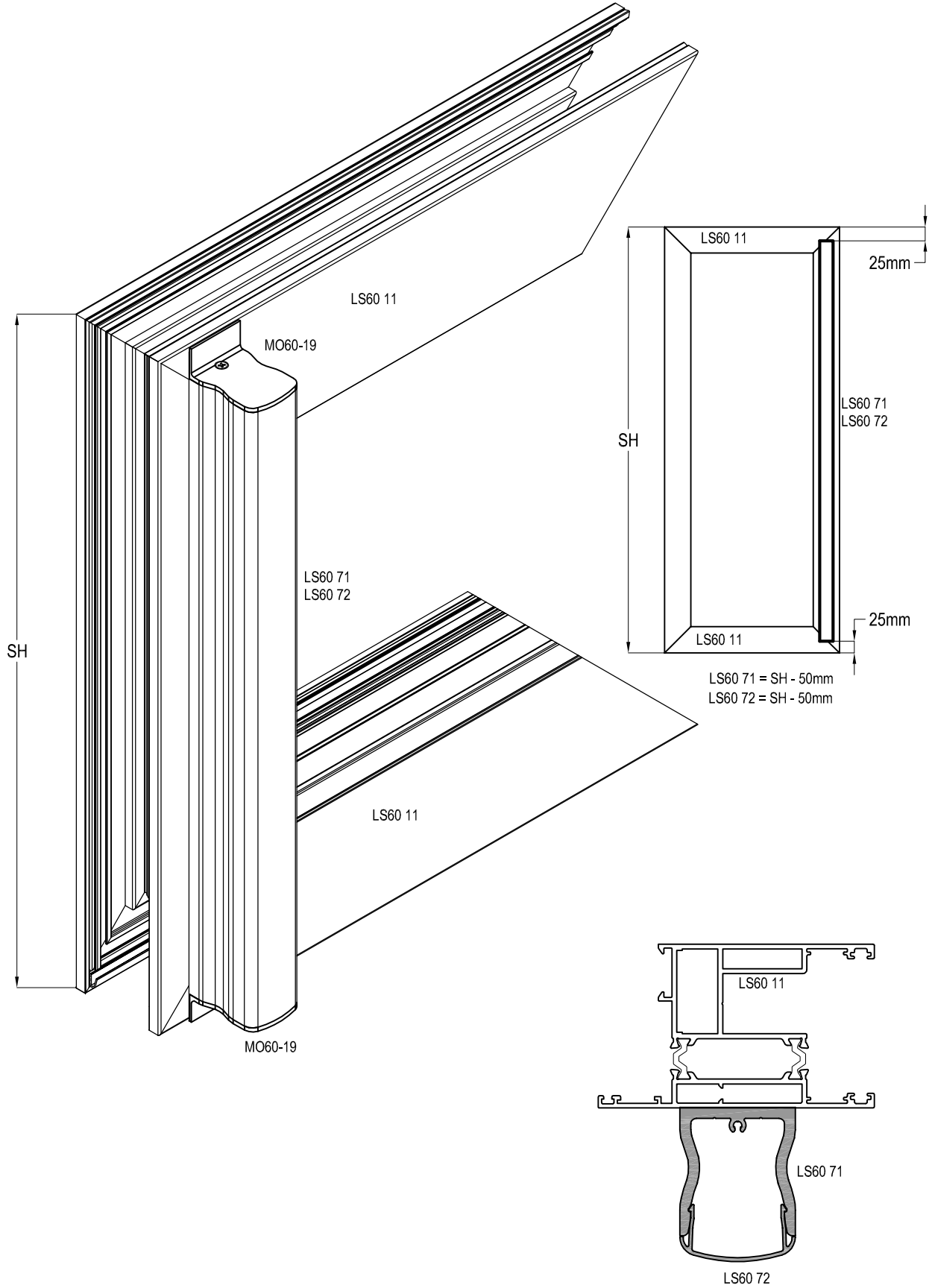



**LS60 - 1,8mm**

YALITIMLI KALDIR-SÜR SİSTEM  
THERMAL LIFT&SLIDE SYSTEM



**ALT-ÜST HAVA KESİCİ MONTAJI**  
ASSEMBLY FOR CENTRAL SEALING- TOP & BOTTOM

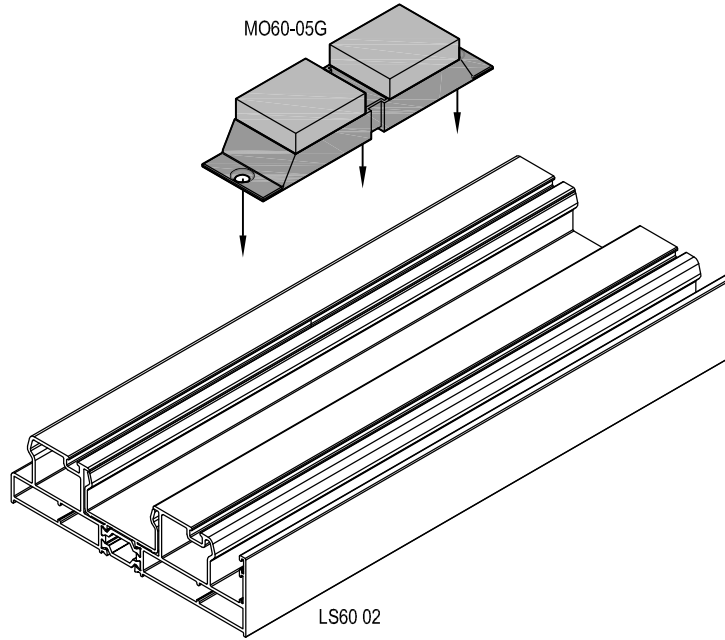
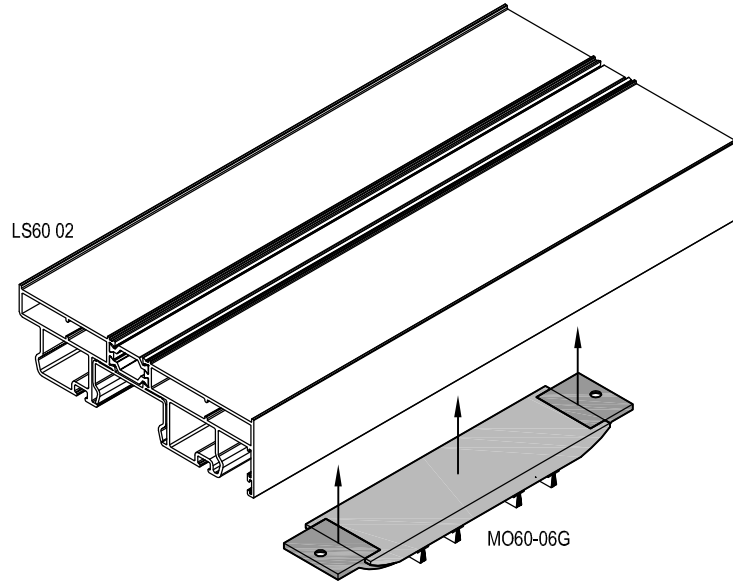



**LS60 - 1,8mm**

YALITIMLI KALDIR-SÜR SİSTEM  
THERMAL LIFT&SLIDE SYSTEM

**ASISTAL**

**4 LÜ KANAT ORTA BİRLEŞİM MONTAJI**  
ASSEMBLY FOR 4 SASH MIDDLE SECTION

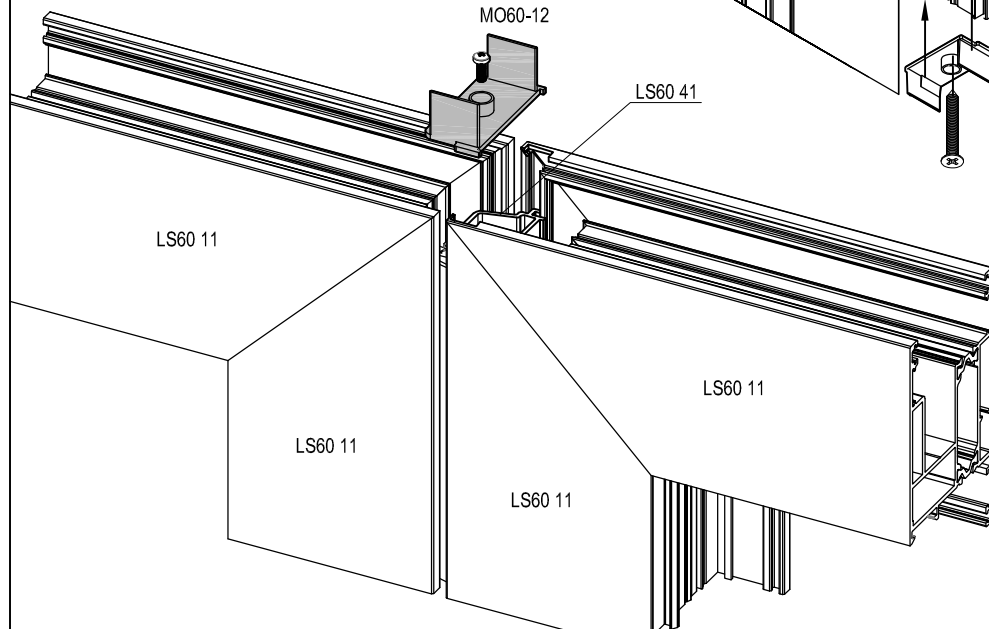
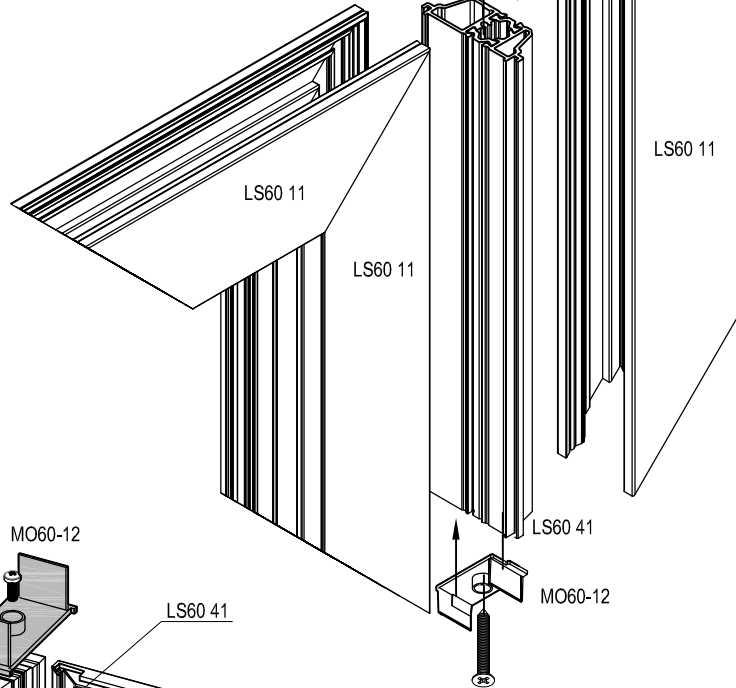
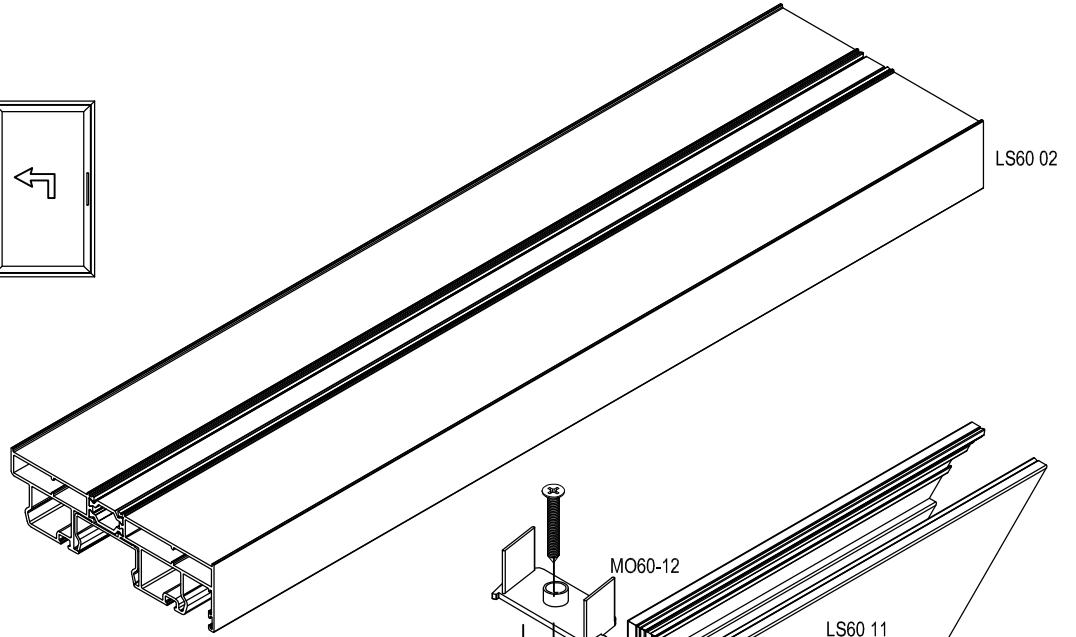
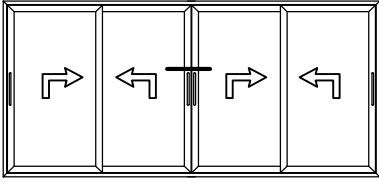

**LS60 - 1,8mm**

YALITIMLI KALDIR-SÜR SİSTEM  
THERMAL LIFT&SLIDE SYSTEM



**SABİTLİ KASADA ORTA KANAT BİRLEŞİM MONTAJI**  
ASSEMBLY FOR SASH FIXING MEETING STILE

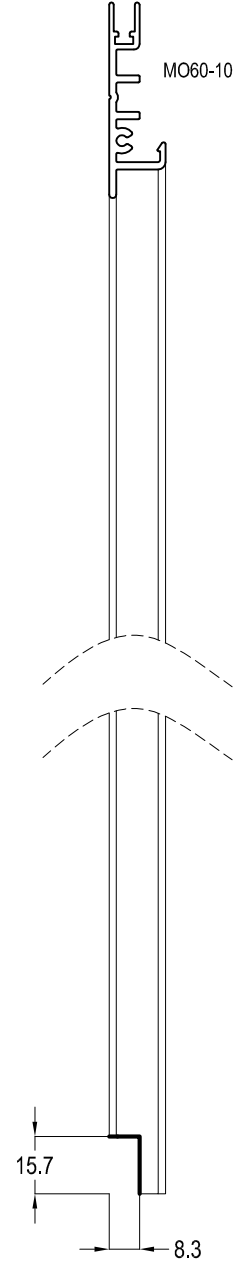
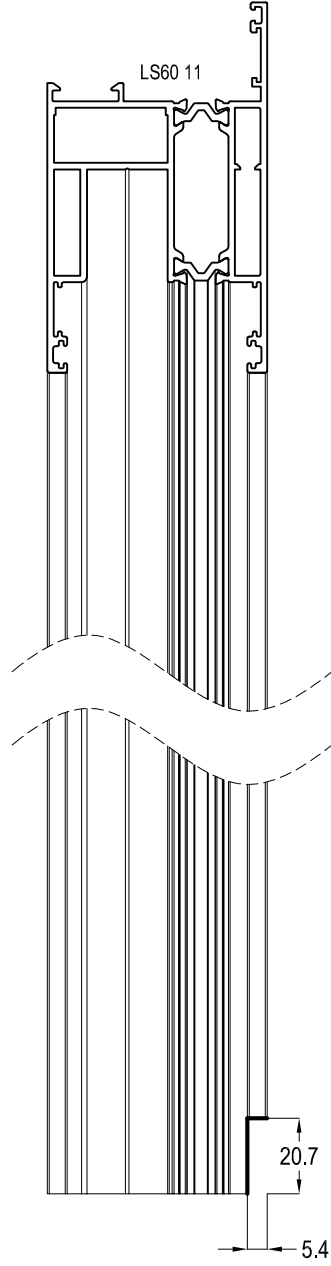
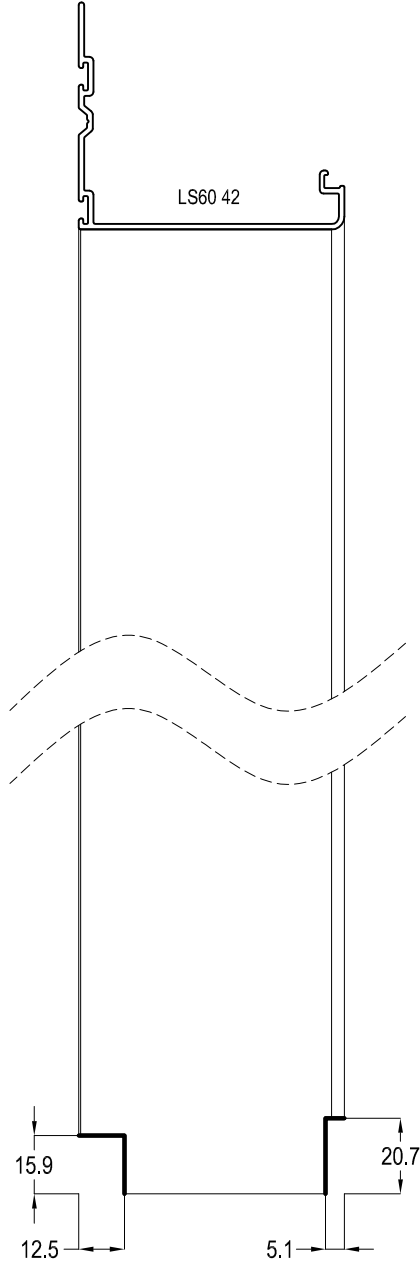
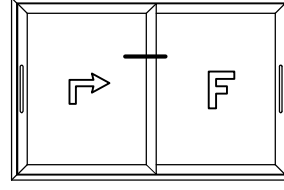

**LS60 - 1,8mm**

YALITIMLI KALDIR-SÜR SİSTEM  
THERMAL LIFT&SLIDE SYSTEM



**SABİTLİ KASADA ORTA KANAT BİRLEŞİM MONTAJI**  
ASSEMBLY FOR SASH FIXING MEETING STILE

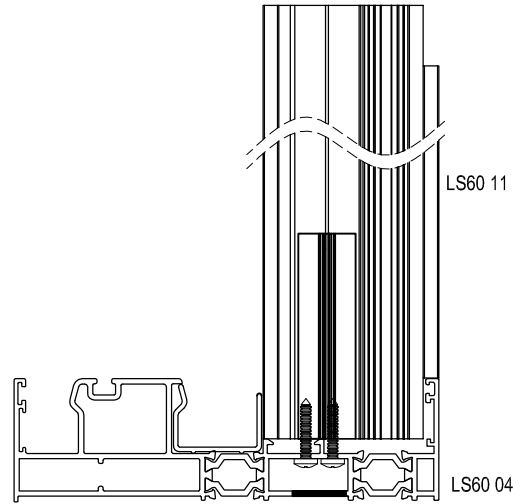
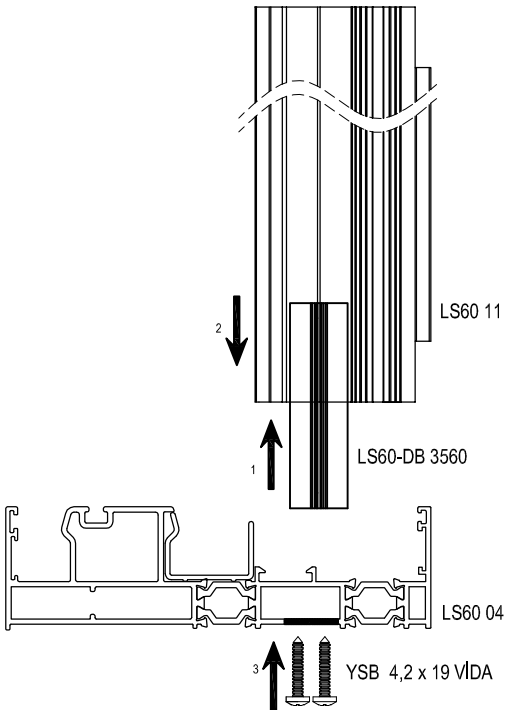
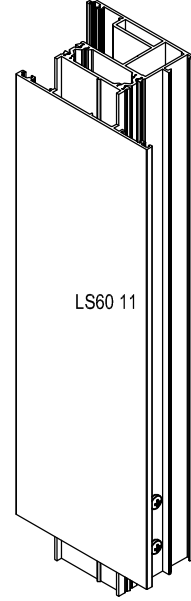
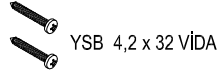
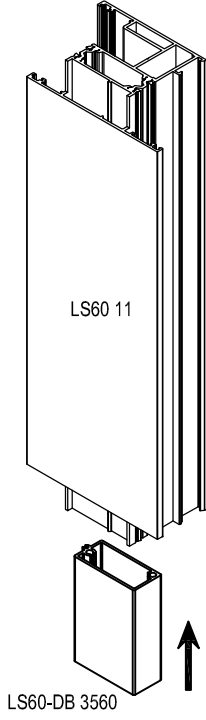
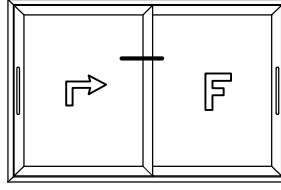

LS60 - 1,8mm

YALITIMLI KALDIR-SÜR SİSTEM  
THERMAL LIFT&SLIDE SYSTEM



SABİTLİ KASADA ORTA KANAT BİRLEŞİM MONTAJI  
ASSEMBLY FOR SASH FIXING MEETING STILE

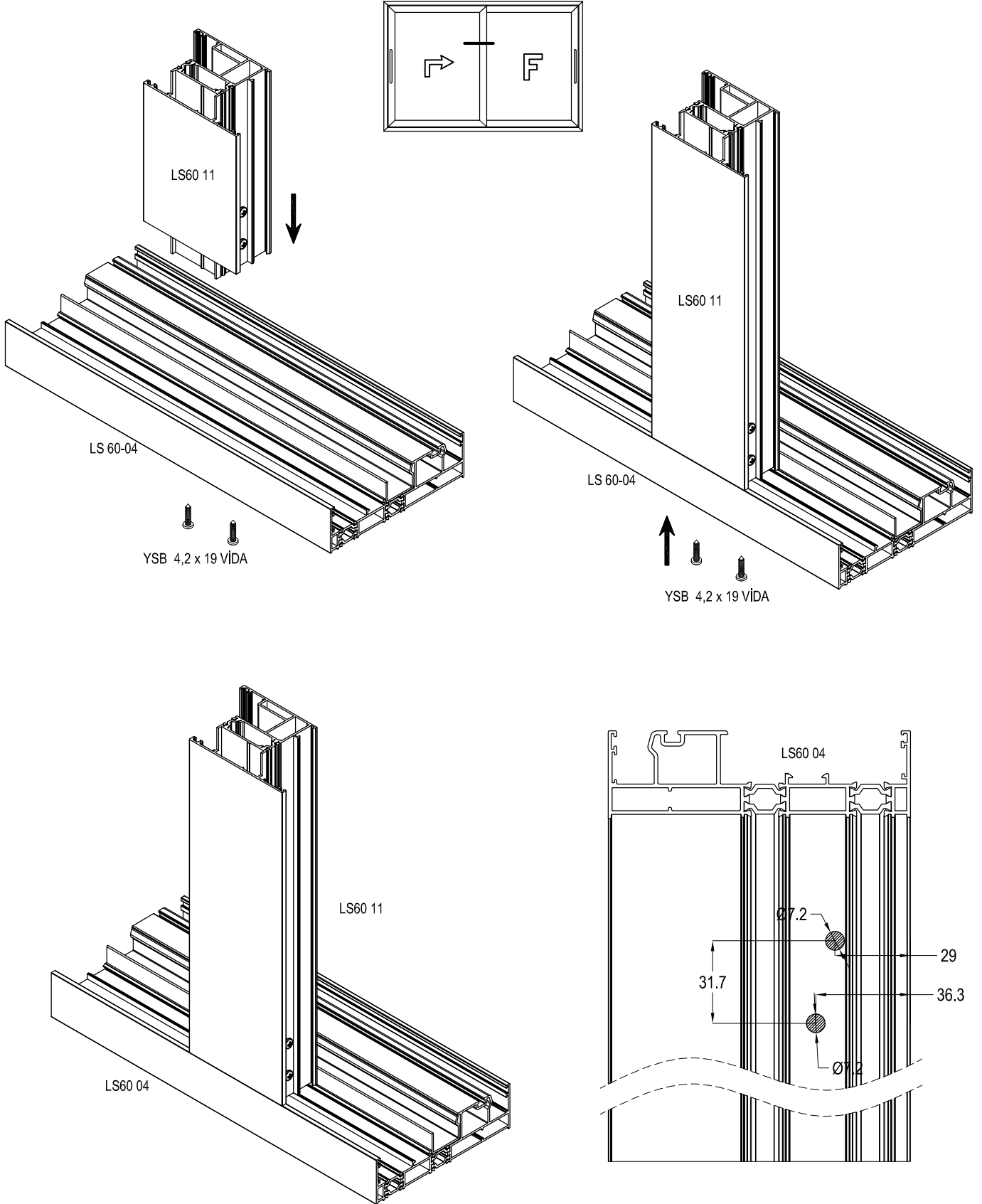

**LS60 - 1,8mm**

YALITIMLI KALDIR-SÜR SİSTEM  
THERMAL LIFT&SLIDE SYSTEM



**SABİTLİ KASADA ORTA KANAT BİRLEŞİM MONTAJI**  
ASSEMBLY FOR SASH FIXING MEETING STILE

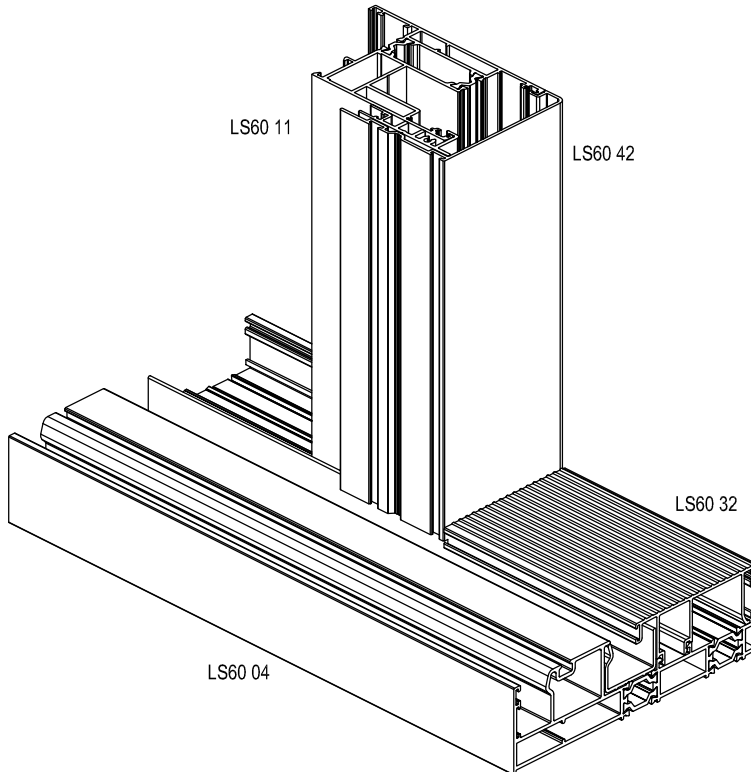
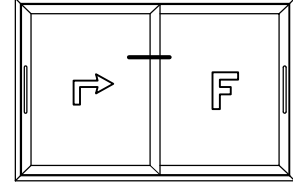
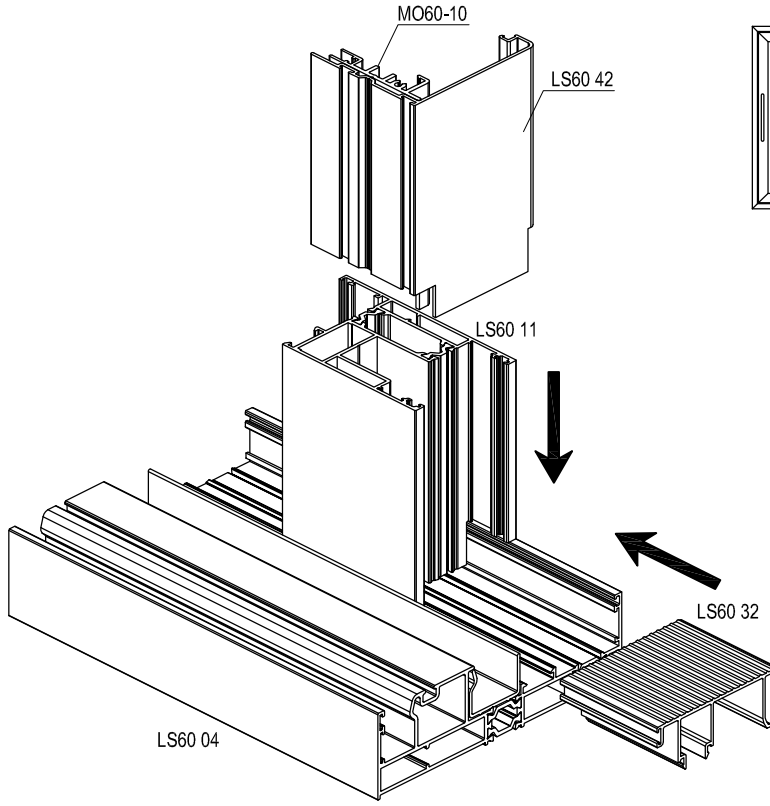

# LS60 - 1,8mm

YALITIMLI KALDIR-SÜR SİSTEM  
THERMAL LIFT&SLIDE SYSTEM

## ASISTAL

### İSPANYOLET KİLİTLEME NORMAL SÜRME İÇİN : ASI-ISP 15 MULTI POINT LOCKING FOR NORMAL SLIDING : ASI-ISP 15

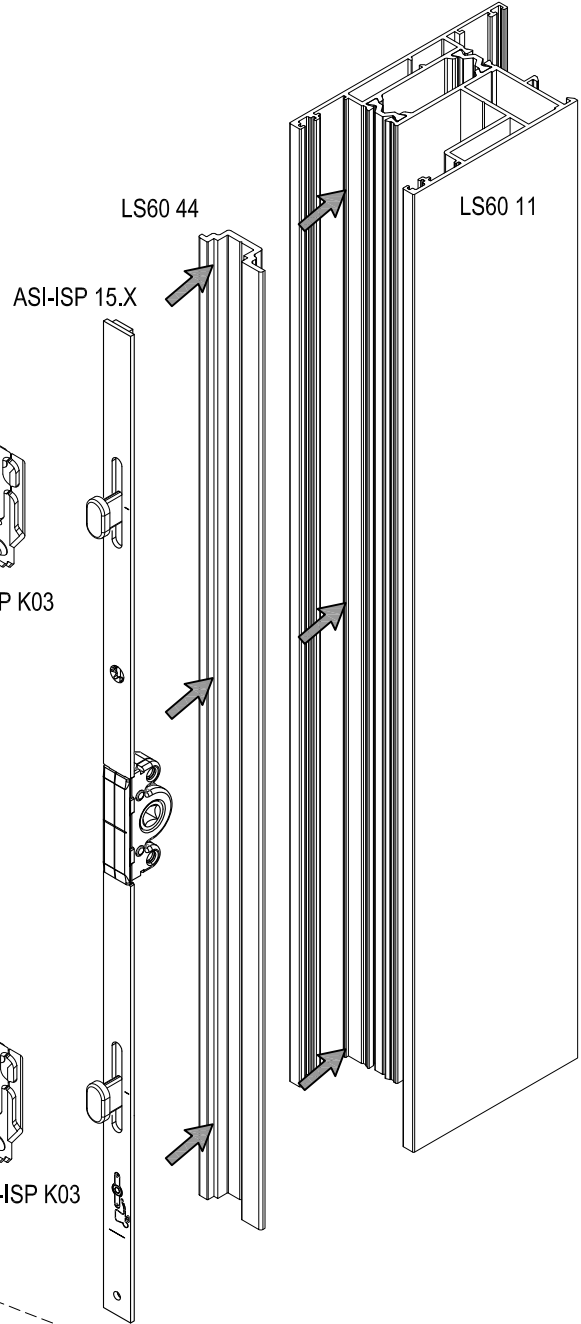
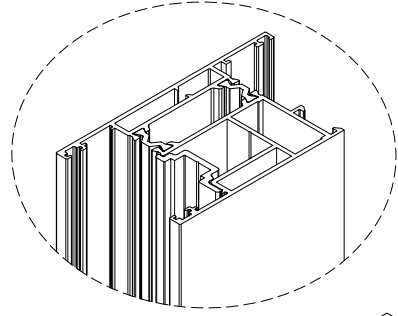
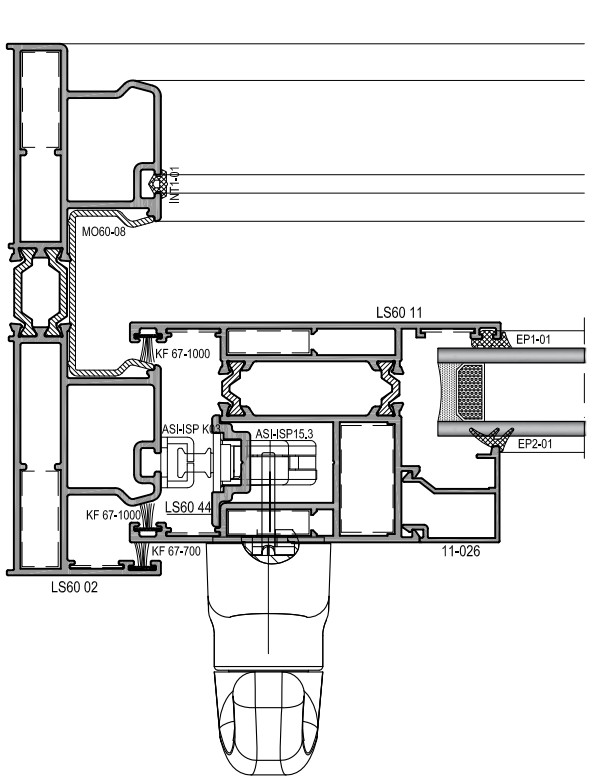

ASI-ISP15.1 (600 mm LİK İSPANYOLET İÇİN)  
KANAT YÜKSEKLİĞİ (sash height) < 1100mm  
LS60 44 = 600mm X 1 ADET  
ASI-ISP K03 = 2 ADET

ASI-ISP15.2 (1000mm LİK İSPANYOLET İÇİN)  
1900mm < KANAT YÜKSEKLİĞİ (sash height) > 1100mm  
LS60 44 = 1000mm X 1 ADET  
ASI-ISP K03 = 2 ADET

ASI-ISP15.3 (1800mm LİK İSPANYOLET İÇİN)  
KANAT YÜKSEKLİĞİ (sash height) > 1900mm  
LS60 44 = 1800mm X 1 ADET  
ASI-ISP K03 = 3 ADET

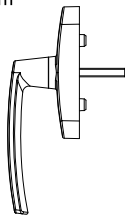

ASI-WH 002

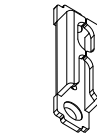

ASI-ISP K03

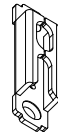

ASI-ISP K03

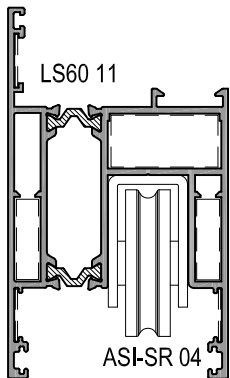

ASI-SR 04  
150KG/RULMAN  
KANAT TAŞIMA KAPASİTESİ=300kg  
SASH CARRY CAPACITY = 300kg

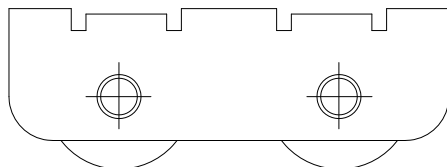
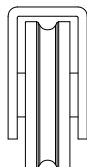



## 2 HAREKETLİ KANAT KESİM ÖLÇÜLERİ 2 SLIDING SASHES CUTTING SIZE

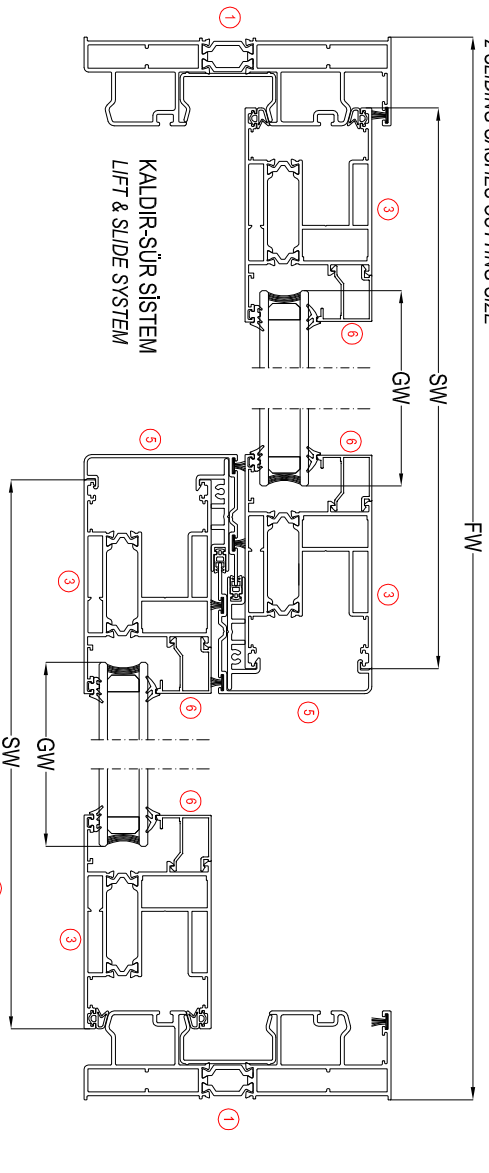

CAM KESİM ÖLÇÜLERİ / GLASS CUTTING SIZES	
KOD / Code	TANIMI / Description
GW	CAM GENİŞLİK / Sash Glass Width
GH	CAM YÜKSEKLİK / Sash Glass Height

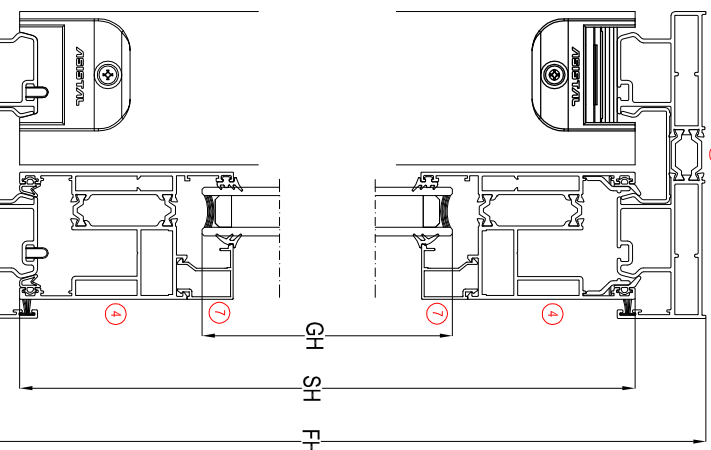

PROFİLLER / PROFILES					
NO / Number	ADET / UNIT	KOD / Code	PROFİL ÇİZİMİ / Drawing	PROFİL TANIMI / Description	KESİM ÖLÇÜSÜ / Cutting Dimensions
1	2	LS80-02		DÜŞEV KASA PROFİLİ / Vertical Frame Profile	FH
2	2	LS80-02		YATAY KASA PROFİLİ / Horizontal Frame Profile	FV
3	4	LS80-11		DÜŞEV KANAT PROFİLİ / Vertical Sash Profile	SH=H±7mm
4	4	LS80-11		YATAY KANAT PROFİLİ / Horizontal Frame Profile	SH=H±7mm
5	2	LS80-42		KENET PROFİLİ / Central Locking Profile	LSH 42xSH
6	4	11_026		DÜŞEV CAM ÇITASI / Vertical Glazing Bead	G1=SH±202mm
7	4	11_026		YATAY CAM ÇITASI / Horizontal Glazing Bead	G2=SH±150mm
PVC	2	MO80-10		KENET PVC PROFİLİ / Central Locking PVC Profile	SH
PVC	2	MO80-08		YATAY KASA KANAL PVC / Horizontal PVC Channel Profile	FV
PVC	2	MO80-08		YATAY KASA KANAL PVC / Horizontal PVC Channel Profile	FH
PVC	2	ASHNR-01		ÇELİK RAY PROFİLİ / Steel Rail Profile	FV-86mm

### FİTİLLER / GASKETS

MİKTAR / Unit	KOD / Code	PROFİL ÇİZİMİ / Drawing	PROFİL TANIMI / Description	KESİM ÖLÇÜSÜ / Cutting Dimensions
mt	EP-101		DİŞ CAM FİTİLİ / Outer Glazing Gasket	4x(G1+G2)
mt	EP-201		İÇ CAM FİTİLİ / Inner Glazing Gasket	4x(G1+G2)
mt	EP80-03		KANAT ÜST FİTİLİ / Sash Gasket	4 x SW
mt	EP80-04		KANAT FİTİLİ / Central Locking Gasket	2 x SH
mt	EP80-05		KANAT FİTİLİ / Sash Gasket	4xSH+4xSW
mt	INT-101		KASA FİTİLİ / Frame Gasket	4x(FH) + 2x(FW)
mt	KF-67-600		FİRÇA FİTİLİ / Brush Gasket - 6mm	4 x SH
mt	KF-67-700		FİRÇA FİTİLİ / Brush Gasket - 7mm	2x(FH)+2x(FW)

### AKSESUARLAR / ACCESSORIES

2 Adet / Pcs	MO80-01		ALT KENET KAPAĞI / Innehook Profile Cap-Bottom
2 Adet / Pcs	MO80-02		ÜST KENET KAPAĞI / Innehook Profile Cap-Top
2 Adet / Pcs	MO80-03		MO80-10 ALT KAPAĞI / Bottom Cover Profile
2 Adet / Pcs	MO80-04		MO80-10 ÜST KAPAĞI / Top Cover Profile
1 Adet / Pcs	MO80-05G		ALT HAVA KEŞİCİ / Central Sealing - Bottom
1 Adet / Pcs	MO80-05G		ÜST HAVA KEŞİCİ / Central Sealing - Top
8 Adet / Pcs	MO80-13		KANAT DENGELERİNE PLASTİĞİ / Sash Stabilization Spacer
28 Adet / Pcs	AS-HS8 19.1		KÖŞE GÖNYESİ / Corner Alignment
8 Adet / Pcs	AS-İPB 1126		KÖŞE TAKOZU veya FİNLİ BAĞLANTI / Corner Joint Pcs or Pin
8 Adet / Pcs	AS-SKT 1429		KÖŞE TAKOZU / Pcs Corner Joint
16 Adet / Pcs	AS-SKT 2307		KÖŞE TAKOZU / Pcs Corner Joint
2 Tutar / Set	LS80-MEK1		KALDIR-SÜR MEKANİZMASI / Lift&Slide Mechanism

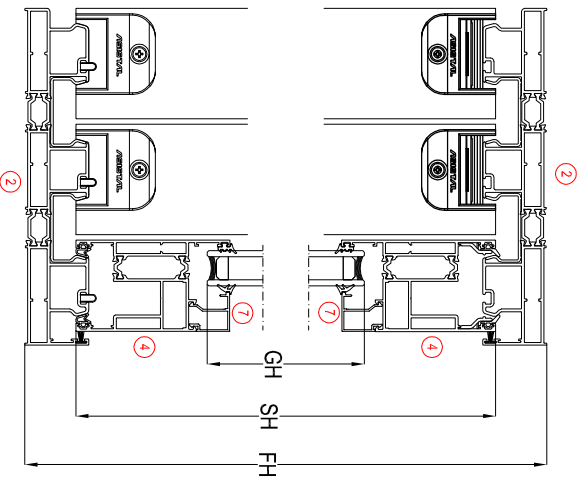
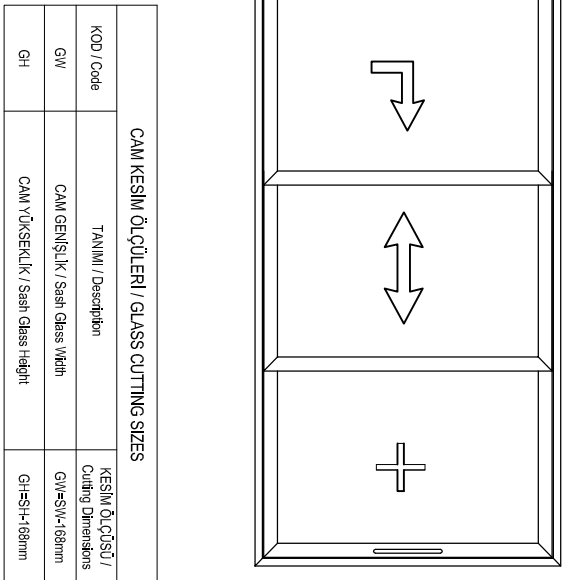
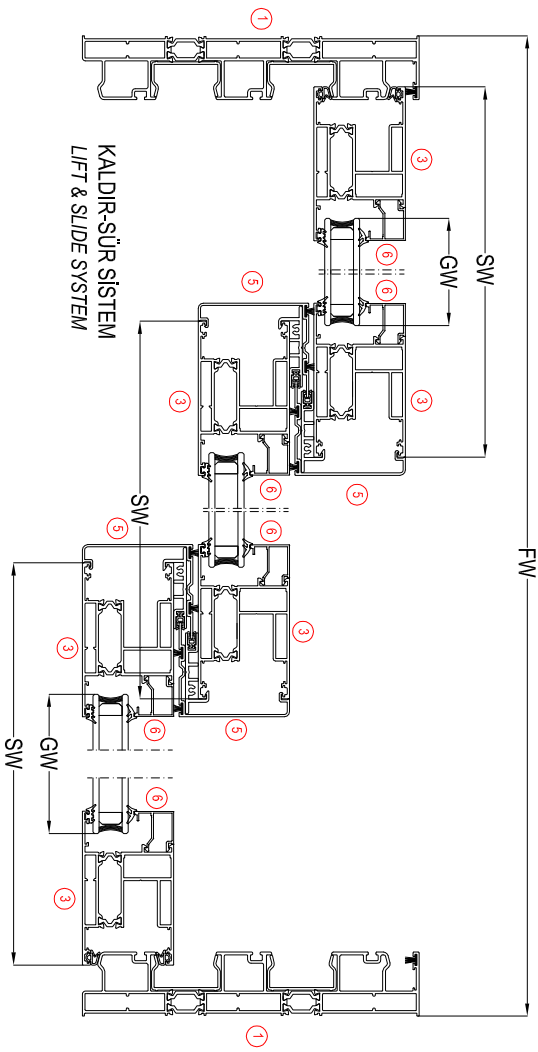

PROFİLLER / PROFILES					
NO / Number	ADET / Unit	KOD / Code	PROFİL ÇİZİMİ / Drawing	PROFİL TANIMI / Description	KESİM ÖLÇÜSÜ / Cutting Dimensions
1	2	LS60 03		DÜŞEV KASA PROFİLİ / Vertical Frame Profile	FH
2	2	LS60 03		YATAY KASA PROFİLİ / Horizontal Frame Profile	FW
3	6	LS60 11		DÜŞEV KANAT PROFİLİ / Vertical Sash Profile	SH=FW-6mm
4	6	LS60 11		YATAY KANAT PROFİLİ / Horizontal Frame Profile	SW=FW-3*37,2
5	4	LS60 42		KENET PROFİLİ / Central Locking Profile	LS40 42=SH
6	6	11_026		DÜŞEV CAM ÇITASI / Vertical Glazing Bead	G1=SH-202mm
7	6	11_026		YATAY CAM ÇITASI / Horizontal Glazing Bead	G2=SW-158mm
4	4	MO80-10		KENET PVC PROFİL / Central Locking PVC Profile	SH
4	4	MO80-08		YATAY KASA KANAL PVC / Horizontal PVC Channel Profile	FW
4	4	MO80-08		YATAY KASA KANAL PVC / Horizontal PVC Channel Profile	FH
3	3	ASHNR 01		ÇELİK RAY PROFİLİ / Steel Rail Profile	FW-64mm

#### FİTİLLER / GASKETS

MİKTAR / Unit	KOD / Code	PROFİL ÇİZİMİ / Drawing	PROFİL TANIMI / Description	KESİM ÖLÇÜSÜ / Cutting Dimensions
mt	EP1-01		DİŞ CAM FİTİL / Outer Glazing Gasket	6x(G1+G2)
mt	EP2-01		İÇ CAM FİTİL / Inner Glazing Gasket	6x(G1+G2)
mt	EP60-03		KANAT ÜST FİTİL / Sash Gasket	6 x SW
mt	EP60-04		KENET FİTİL / Central Locking Gasket	4 x SH
mt	EP60-05		KANAT FİTİL / Sash Gasket	4xSH-6xSW
mt	INT1-01		KASA FİTİL / Frame Gasket	(6xFH) + (3xFW)
mt	KF 67-400		FIRÇA FİTİL / Brush Gasket - 6mm	8 x SH
mt	KF 67-700		FIRÇA FİTİL / Brush Gasket - 7mm	(2xFH)+(2xFW)

#### AKSESUARLAR / ACCESSORIES

4 Adet / Pcs	MO80-01		ALTİ KENET KAPAĞI / Inletlock Profile Cap-Bottom	
4 Adet / Pcs	MO80-02		ÜST KENET KAPAĞI / Inletlock Profile Cap-Top	
4 Adet / Pcs	MO80-03		MO80-10 ALTİ KAPAK PROFİLİ / Bottom Cover Profile	
4 Adet / Pcs	MO80-04		MO80-10 ÜST KAPAK PROFİLİ / Top Cover Profile	
2 Adet / Pcs	MO80-05G		ALTİ HAVA KESİCİ / Central Sealing - Bottom	
2 Adet / Pcs	MO80-06G		ÜST HAVA KESİCİ / Central Sealing - Top	
12 Adet / Pcs	MO80-03		KANAT DENGELEME PLASTİĞİ / Sash Stabilization Spacer	
40 Adet / Pcs	AS1-SB 19,1		KÖŞE GÖNVERİSİ / Corner Alignment	
12 Adet / Pcs	AS1-PB 1126		KÖŞE TAKOZU veya PİVALİ BAĞLANTI / Corner Joint	
12 Adet / Pcs	AS1-KT 1126		KÖŞE TAKOZU / Pies of FH	
12 Adet / Pcs	AS1-KT 1429		KÖŞE TAKOZU / Pies Corner Joint	
24 Adet / Pcs	AS1-KT 2307		KÖŞE TAKOZU / Pies Corner Joint	
2 Adet / Pcs	LS60-DB3560		KANAT SABİTLEME PARÇASI / Sash Fixing	
2 Takım / Set	LS60-MEK1		KALDIR-SÜR MEKANİZMASI / Lift&Slide Mechanism	

## 2 Lİ RAYDA 3 LÜ KANAT KESİM ÖLÇÜLERİ

### 3 SASHES CUTTING SIZE FOR DOUBLE RAIL FRAME

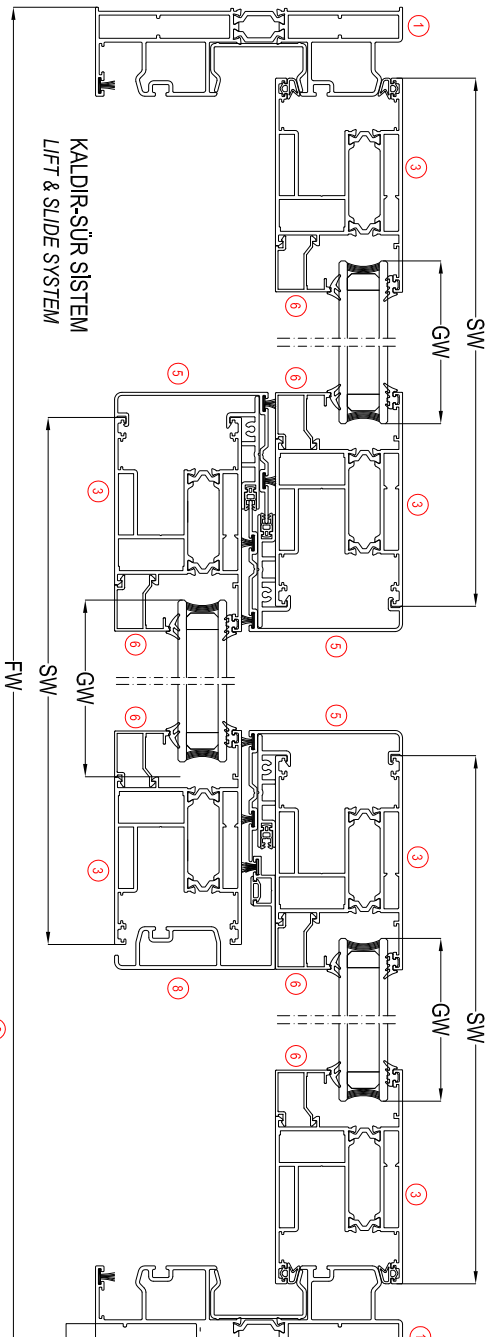

#### PROFİLLER / PROFILES

NO / Number	ADET / Unit	KOD / Code	PROFİL ÇİZİMİ / Drawing	PROFİL TANIMI / Description	KESİM ÖLÇÜSÜ / Cutting Dimensions
1	2	LS80 02		DÜŞEV KASA PROFİLİ / Vertical Frame Profile	FH
2	2	LS80 02		YATAY KASA PROFİLİ / Horizontal Frame Profile	FV
3	6	LS80 11		DÜŞEV KANAT PROFİLİ / Vertical Sash Profile	SH=H±7mm
4	6	LS80 11		YATAY KANAT PROFİLİ / Horizontal Sash Profile	SW=F±W±37mm
5	4	LS80 42		KENET PROFİLİ / Central Locking Profile	LSH±4±SH
6	6	11_026		DÜŞEV CAM GİTİŞİ / Vertical Glazing Bead	G±SH±202mm
7	6	11_026		YATAY CAM GİTİŞİ / Horizontal Glazing Bead	G±SH±158mm
8	1	LS80 43		3 LÜ KANAT ADAPTÖR PROFİLİ / Adapter Profile	FH±4mm
PVC	3	MO80-10		KENET PVC PROFİLİ / Central Locking PVC Profile	SH
PVC	2	MO80-08		YATAY KASA KANAL PVC / Horizontal PVC Channel Profile	FV
PVC	2	MO80-08		YATAY KASA KANAL PVC / Horizontal PVC Channel Profile	FH
PVC	2	MO80-08		YATAY KASA KANAL PVC / Horizontal PVC Channel Profile	FV±4mm

#### FİTİLLER / GASKETS

MİKTAR / Unit	KOD / Code	PROFİL ÇİZİMİ / Drawing	PROFİL TANIMI / Description	KESİM ÖLÇÜSÜ / Cutting Dimensions
nt	EP-1-01		DİŞ CAM FİTİLİ / Outer Glazing Gasket	6x(G+G2)
nt	EP-2-01		İÇ CAM FİTİLİ / Inner Glazing Gasket	6x(G+G2)
nt	EP80-03		KANAT ÜST FİTİLİ / Sash Gasket	6 x SW
nt	EP80-04		KENET FİTİLİ / Central Locking Gasket	3 x SH
nt	EP80-05		KANAT FİTİLİ / Sash Gasket	6xSH+60xSW
nt	NT1-01		KASA FİTİLİ / Frame Gasket	4x(FH) + 2x(FV)
nt	NT2-02		KANAL FİTİLİ / Adapter Gasket	1xSH
nt	KF 67-600		FİRÇA FİTİL / Brush Gasket - 6mm	6 x SH
nt	KF 67-700		FİRÇA FİTİL / Brush Gasket - 7mm	2x(FH)+2x(FV)
nt	KF 67-1000		FİRÇA FİTİL / Brush Gasket - 10mm	1xSH

#### AKSESUARLAR / ACCESSORIES

MİKTAR / Pcs	KOD / Code	AKSESUAR ÇİZİMİ / Drawing	AKSESUAR TANIMI / Description
3 Adet / Pcs	MO80-01		ALT KENET KAPAĞI / Innerlock Profile Cap-Bottom
3 Adet / Pcs	MO80-02		ÜST KENET KAPAĞI / Innerlock Profile Cap-Top
3 Adet / Pcs	MO80-03		MO80-10 ALT KAPAK PROFİLİ / Bottom Cover Profile
3 Adet / Pcs	MO80-04		MO80-10 ÜST KAPAK PROFİLİ / Top Cover Profile
2 Adet / Pcs	MO80-05G		ALT HAVA KESİCİ / Central Sealing - Bottom
2 Adet / Pcs	MO80-06G		ÜST HAVA KESİCİ / Central Sealing - Top
12 Adet / Pcs	MO80-13		KANAT DENGELEME PLASTİĞİ / Sash Stabilization Spacer
40 Adet / Pcs	AS1-S8 19,1		KÖŞE GÖNYESİ / Corner Alignment
8 Adet / Pcs	ASHPB 1126		KÖŞE TAKOZU veya FİTİL BAĞLANTI / Corner Joint Press or Pin
24 Adet / Pcs	ASHKT 1126		KÖŞE TAKOZU / Pcs Corner Joint
12 Adet / Pcs	ASHKT 1429		KÖŞE TAKOZU / Pcs Corner Joint
24 Adet / Pcs	ASHKT 2307		KÖŞE TAKOZU / Pcs Corner Joint
2 Adet / Pcs	LS80-DB360		KANAT SABİTLEME PARÇASI / Sash Fixing
2 Takım / Set	LS80-AHEK1		KALDIR-SÜR MEKANİZMASI / Lift&Slide Mechanism

CAM KESİM ÖLÇÜLERİ / GLASS CUTTING SIZES		
KOD / Code	TANIMI / Description	KESİM ÖLÇÜSÜ / Cutting Dimensions
GW	CAM GENİŞLİK / Sash Glass Width	GW=SW-172mm
GH	CAM YÜKSEKLİK / Sash Glass Height	GH=SH-172mm

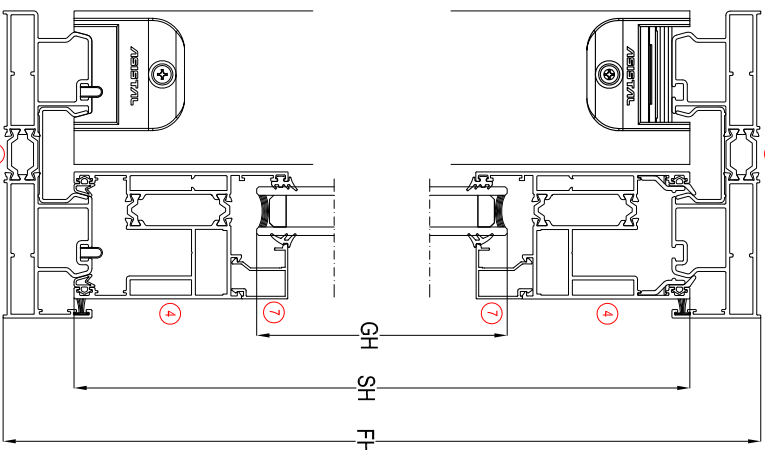
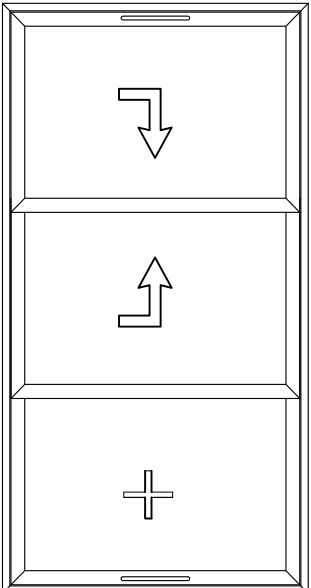

4 LÜ KANAT KESİM ÖLÇÜLERİ  
4 SLIDING SASHES CUTTING SIZE

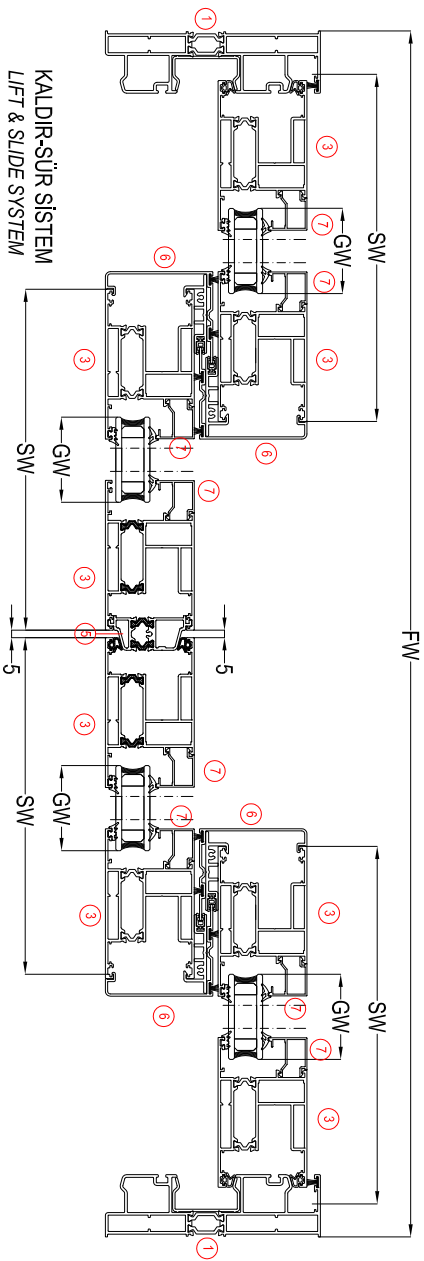

CAMI KESİM ÖLÇÜLERİ / GLASS CUTTING SIZES		
KOD / Code	TANIMI / Description	KESİM ÖLÇÜSÜ / Cutting Dimensions
GW	CAM GENİŞLİK / Sash Glass Width	GW=SW-172mm
GH	CAM YÜKSEKLİK / Sash Glass Height	GH=SH-172mm

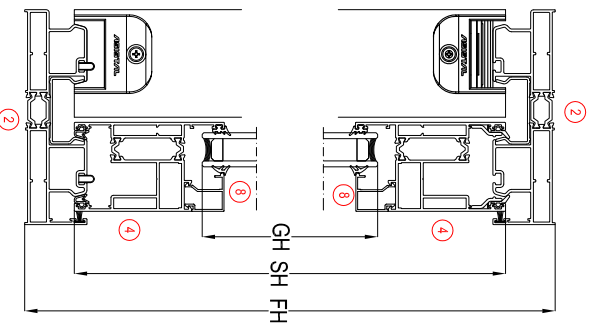
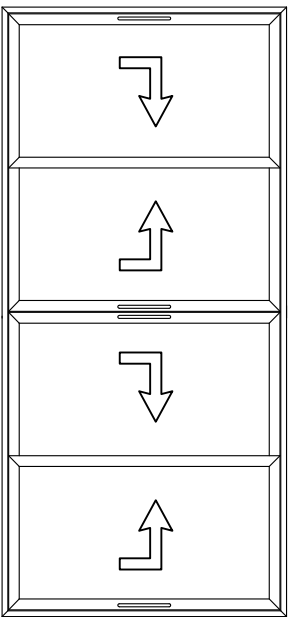

PROFİLLER / PROFILES

SIRA NO / Number	ADET / Unit	KOD / Code	PROFİL ÇİZİMİ / Drawing	PROFİL TANIMI / Description	KESİM ÖLÇÜSÜ / Cutting Dimensions
1	2	LS80 04		DÜŞEY KASA PROFİLİ / Vertical Frame Profile	FH
2	2	LS80 04		YATAY KASA PROFİLİ / Horizontal Frame Profile	FW
3	8	LS80 11		DÜŞEY KANAT PROFİLİ / Vertical Sash Profile	SH=FW-67mm
4	8	LS80 11		YATAY KANAT PROFİLİ / Horizontal Sash Profile	SW=FW-4266mm
5	1	LS80-41		ADAPTÖR PROFİLİ / Adapter Profile	LS80 41=SH-80mm
6	4	LS80-42		KENET PROFİLİ / Central Locking Profile	LS40 42=SH
7	8	11.026		DÜŞEY CAM ÇIĞASI / Vertical Glazing Bead	G1=SH-202mm
8	8	11.026		YATAY CAM ÇIĞASI / Horizontal Glazing Bead	G2=SW-158mm
4		MO80-10		KENET PVC PROFİLİ / Central Locking PVC Profile	SH
2		MO80-08		YATAY KASA KANAL PVC / Horizontal PVC Channel	SW
2		MO80-08		DÜŞEY KASA KANAL PVC / Vertical PVC Channel	SH
2		ASHNK 01		ÇELİK RAY PROFİLİ / Steel Rail Profile	FW=84mm

FİTİLLER / GASKETS

MİKTAR / Unit	KOD / Code	PROFİL ÇİZİMİ / Drawing	PROFİL TANIMI / Description	KESİM ÖLÇÜSÜ / Cutting Dimensions
mt	EP-01		DIŞ CAM FİTİLİ / Outer Glazing Gasket	8x(G1+G2)
mt	EP-201		İÇ CAM FİTİLİ / Inner Glazing Gasket	8x(G1+G2)
mt	EP90-03		KANAT ÜST FİTİLİ / Sash Gasket	8 x SW
mt	EP90-04		KENET FİTİLİ / Central Locking Gasket	4 x SH
mt	EP90-05		KANAT FİTİLİ / Sash Gasket	(8xSH)+(8xSW)
mt	NTT-01		KASA FİTİLİ / Frame Gasket	(4xFH)+(2xFW)
mt	KF 67-800		FİRÇA FİTİLİ / Brush Gasket - 6mm	8xSH
mt	KF 67-700		FİRÇA FİTİLİ / Brush Gasket - 7mm	(2xFH)+(2xFW)

AKSESUARLAR / ACCESSORIES

4 Adet / Pcs	MO80-01		ALT KENET KAPAĞI / Innerlock Profile Cap-Bottom	
4 Adet / Pcs	MO80-02		ÜST KENET KAPAĞI / Innerlock Profile Cap-Top	
4 Adet / Pcs	MO80-03		MO80-10 ALT KAPAK PROFİLİ / Bottom Cover Profile	
4 Adet / Pcs	MO80-04		MO80-10 ÜST KAPAK PROFİLİ / Top Cover Profile	
2 Adet / Pcs	MO80-05G		ALT HAVA KESİCİ / Central Sealing - Bottom	
2 Adet / Pcs	MO80-06G		ÜST HAVA KESİCİ / Central Sealing - Top	
2 Adet / Pcs	MO80-12		ADAPTÖR KAPAĞI / Adapter Cover	
16 Adet / Pcs	MO80-13		KANAT DENGELENE PLASTİĞİ / Sash Stabilization Spacer	
52 Adet / Pcs	ASH-8B 19.1		KÖŞE GÖNYESİ / Corner Alignment	
8 Adet / Pcs	ASH-8B 1126		KÖŞE TAKOZU veya PİMLİ BAĞLI ANTI Köşe Juhit	
16 Adet / Pcs	ASHKT 1429		KÖŞE TAKOZU / Pias Corner Juhit	
32 Adet / Pcs	ASHKT 2307		KÖŞE TAKOZU / Pias Corner Juhit	
2 Takım / Set	LS80-MEK1		KALDIR-SÜR MEKANİZMASI / Lift&Slide Mechanism	
1 Takım / Set	LS80-MEK1D		KALDIR-SÜR MEKANİZMASI / Lift&Slide Mechanism	

**SABİTLİ KASADA 1 HAREKETLİ KANAT KESİM ÖLÇÜLERİ**  
1 SLIDING SASH IN FIXED FRAME CUTTING SIZE

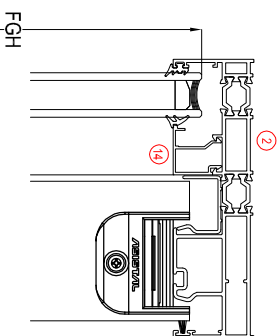
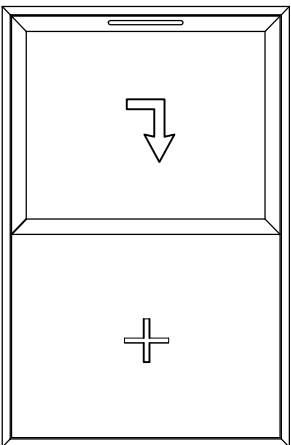
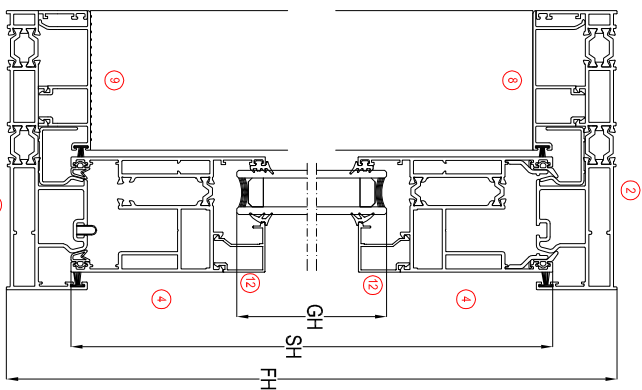
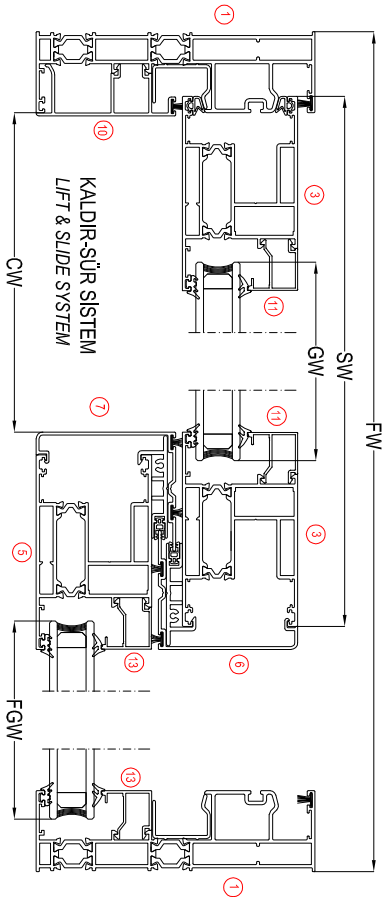

CAM KESİM ÖLÇÜLERİ / GLASS CUTTING SIZES	
KOD / Code	TANIMI / Description
GW	HAREKETLİ KANAT CAM GENİŞLİK / Sash Glass Width
GH	HAREKETLİ KANAT CAM YÜKSEKLİK / Sash Glass Height
FGW	SABİT KISIM CAM GENİŞLİK / Fixed Glass Width
FGH	SABİT KISIM CAM YÜKSEKLİK / Fixed Glass Height

**PROFİLLER / PROFILES**

NO / Number	ADET / Unit	KOD / Code	PROFİL ÇİZİMİ / Drawing	PROFİL TANIMI / Description	KESİM ÖLÇÜSÜ / Cutting Dimensions
1	2	LS80 04		DÜŞEY KASA PROFİLİ / Vertical Frame Profile	FH
2	2	LS80 04		YATAY KASA PROFİLİ / Horizontal Frame Profile	FW
3	2	LS80 11		DÜŞEY KANAT PROFİLİ / Vertical Sash Profile	SH=H+67mm
4	2	LS80 11		YATAY KANAT PROFİLİ / Horizontal Sash Profile	SW=H+267mm
5	1	LS80 11		ORTA KAVTİ PROFİLİ / Transom Locking Profile	TH=H+420mm
6	1	LS80 42		KENET PROFİLİ / Central Locking Profile	LS40 42-SH
7	1	LS80 42		ORTA KAVTİ KENET PROFİLİ / Transom Cover	FH+3mm
8	1	LS80 31		ÜST KAPAK PROFİLİ / Top Cover Profile	GW=FWZ - 53mm
9	1	LS80 32		ALT KAPAK PROFİLİ / Bottom Cover Profile	GW=FWZ - 53mm
10	1	LS80 31		YAN KAPAK PROFİLİ / Side Cover Profile	GH=H1 - 88 mm
11	2	1L_026		DÜŞEY CAM ÇITASI / Vertical Glazing Bead	G1=SH - 203mm
12	2	1L_026		YATAY CAM ÇITASI / Horizontal Glazing Bead	G2=SW - 159mm
13	2	1L_026		SABİT DÜŞEY CAM ÇITASI / Fixed Vertical Glazing Bead	G3=H1+87mm
14	2	1L_026		SABİT YATAY CAM ÇITASI / Fixed Horizontal Glazing Bead	G4=FWZ-102mm
2	2	MO80-10		KENET PVC PROFİLİ / Central Locking PVC Profile	SH
2	2	MO80-07		YATAY KASA KANALI PVC / Horizontal PVC Channel Profile	FW
2	2	MO80-07		DÜŞEY KASA KANALI PVC / Vertical PVC Channel Profile	FH
1	1	ASHR-01		ÇELİK RAY PROFİLİ / Steel Rail Profile	FW=64mm

**FİTLER / GASKETS**

MİKTAR / Unit	KOD / Code	PROFİL ÇİZİMİ / Drawing	PROFİL TANIMI / Description	KESİM ÖLÇÜSÜ / Cutting Dimensions
mt	EP-401		DİŞ CAM FİTİLİ / Outer Glazing Gasket	2x(G1+G2-G3-G4)
mt	EP-201		İÇ CAM FİTİLİ / Inner Glazing Gasket	2x(G1+G2-G3-G4)
mt	EP80-04		KENET FİTİLİ / Central Locking Gasket	2 x SH
mt	EP80-05		KANAT FİTİLİ / Sash Gasket	(2SH)-(2xSH)
mt	INT-401		KASA FİTİLİ / Frame Gasket	(2FH) + FW
mt	EP80-03		KANAT ÜST FİTİLİ / Sash Gasket	2xSH
mt	KF-67-600		FİTİL FİTİLİ / Bush Gasket - 60mm	4xSH
mt	KF-67-700		FİTİL FİTİLİ / Bush Gasket - 70mm	(2xFH)-(2xFW)-(CH+2xCM)

**AKSESUARLAR / ACCESSORIES**

1 Adet / Pcs	MO80-01		ALT KENET KAPAĞI / Interlock Profile Cap-Bottom	
1 Adet / Pcs	MO80-02		ÜST KENET KAPAĞI / Interlock Profile Cap-Top	
1 Adet / Pcs	MO80-03		MO80-10 ALT KAPAK PROFİLİ / Bottom Cover Profile	
1 Adet / Pcs	MO80-04		MO80-10 ÜST KAPAK PROFİLİ / Top Cover Profile	
1 Adet / Pcs	MO80-05D		ALT HAVA KESİCİ / Central Sealing - Bottom	
1 Adet / Pcs	MO80-06D		ÜST HAVA KESİCİ / Central Sealing - Top	
4 Adet / Pcs	MO80-13		KANAT DENGELERİNE PLASTİK / Sash Stabilization Spacers	
2 Adet / Pcs	LS80-DB 3589		KANAT SABİTLEME PARÇASI / Sash Fitting Part	
20 Adet / Pcs	ASH-SP 18,1		KÖŞE GÖNVEŞİ / Corner Alignment	
8 Adet / Pcs	ASH-PP 1126		KÖŞE TAKOZU 90° / PİVALİ BAĞLANTI / Corner Joint	
4 Adet / Pcs	ASH-KT 1126		KÖŞE TAKOZU / Pres Corner Joint	
8 Adet / Pcs	ASH-KT 2307		KÖŞE TAKOZU / Pres Corner Joint	
1 Takım / Set	LS80-AMEK1		KALDIR-SÜR MEKANİZMASI / Lift&Slide Mechanism	

## SABİTLİ KASADA 2 HAREKETLİ KANAT KESİM ÖLÇÜLERİ 2 SLIDING SASH IN FIXED FRAME CUTTING SIZE

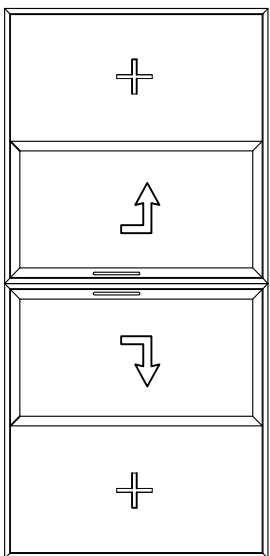
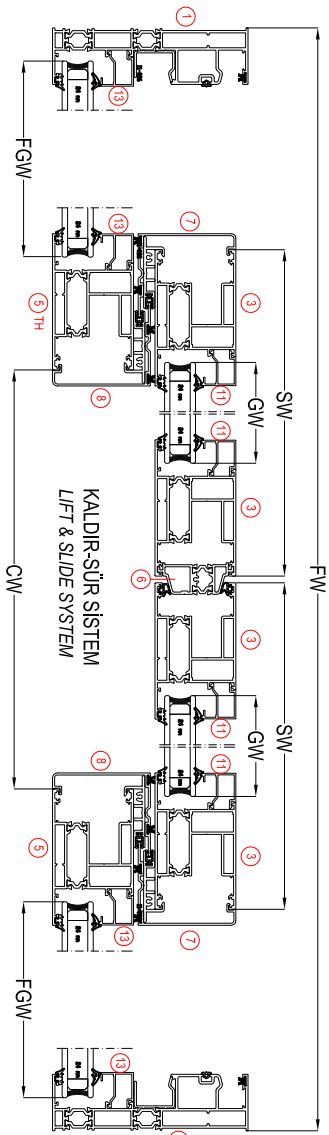

CAM KESİM ÖLÇÜLERİ / GLASS CUTTING SIZES (24mm CAM İÇİN/ 24mm Glazing)		
KOD / Code	TANIMI / Description	KESİM ÖLÇÜSÜ / Cutting Dimensions
GW	HAREKETLİ KANAT CAM GENİŞLİK / Sash Glass Width	GW-SW-172mm
GH	HAREKETLİ KANAT CAM YÜKSEKLİK / Sash Glass Height	GH-SH-172mm
FGW	SABİTLİ KISIM CAM GENİŞLİK / Fixed Glass Width	FGW-FW+457mm
FGH	SABİTLİ KISIM CAM YÜKSEKLİK / Fixed Glass Height	FGH-FH+44mm

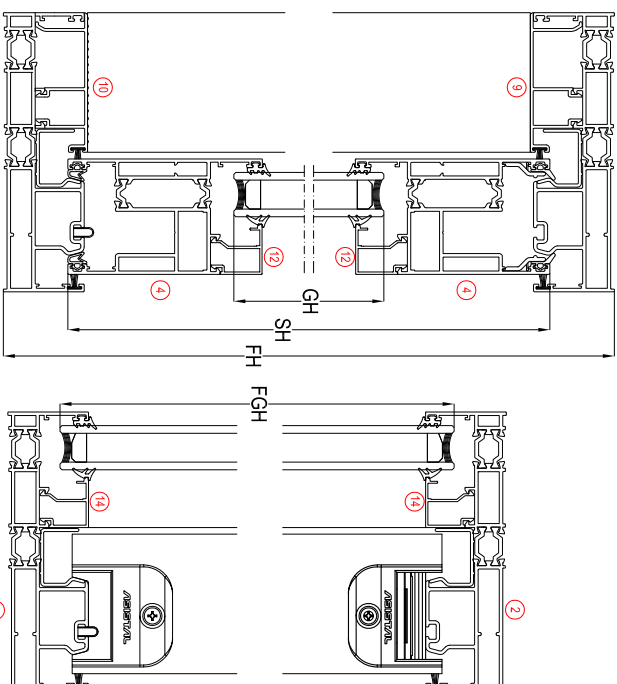

### PROFİLLER / PROFILES

NO / Number	ADET / Unit	KOD / Code	PROFİL ÇİZİMİ / Drawing	PROFİL TANIMI / Description	KESİM ÖLÇÜSÜ / Cutting Dimensions
1	2	LS60 04		DÜŞEY KASA PROFİLİ / Vertical Frame Profile	FH
2	2	LS60 04		YATAY KASA PROFİLİ / Horizontal Frame Profile	FW
3	4	LS60 11		DÜŞEY KANAT PROFİLİ / Vertical Sash Profile	SH=FH+67mm
4	4	LS60 11		YATAY KANAT PROFİLİ / Horizontal Sash Profile	SH=FW+67mm
5	2	LS60 11		ORTA KAVIT PROFİLİ / Transom Locking Profile	TH=FW+43mm
6	1	LS60 41		ADAPTÖR PROFİLİ / Adapter Profile	LS60 41=SH-50mm
7	2	LS60 42		KENET PROFİLİ / Central Locking Profile	LS40 42=SH
8	2	LS60 42		ORTA KAVİT KENET PROFİLİ / Transom Cover	FH+3mm
9	1	LS60 31		ÜST KAPAK PROFİLİ / Top Cover Profile	CV=FW+2146mm
10	1	LS60 32		ALT KAPAK PROFİLİ / Bottom Cover Profile	CV=FW+2146mm
11	4	11_026		DÜŞEY CAM ÇITASI / Vertical Glazing Bead	G1=SH+203mm
12	4	11_026		YATAY CAM ÇITASI / Horizontal Glazing Bead	G2=SW+159mm
13	4	11_026		SABİTLİ DÜŞEY CAM ÇITASI / Fixed Vertical Glazing Bead	G3=FH+67mm
14	4	11_026		SABİTLİ YATAY CAM ÇITASI / Fixed Horizontal Glazing Bead	G4=FW+440mm
	4	MO60-10		KENET PVC PROFİL / Central Locking PVC Profile	SH
	2	MO60-07		YATAY KASA KANAL PVC / Horizontal PVC Channel	FW
	2	MO60-07		DÜŞEY KASA KANAL PVC / Vertical PVC Channel Profile	FH
	1	ASHLR 01		ÇELİK RAY PROFİLİ / Steel Rail Profile	FH+34mm

### FİTİLLER / GASKETS

MİK/AR / Unit	KOD / Code	PROFİL ÇİZİMİ / Drawing	PROFİL TANIMI / Description	KESİM ÖLÇÜSÜ / Cutting Dimensions
mt	EP1-01		DIŞ CAM FİTİL / Outer Glazing Gasket	4*(G1+G2+G3+G4)
mt	EP2-01		İÇ CAM FİTİL / Inner Glazing Gasket	4*(G1+G2+G3+G4)
mt	EP60-03		KANAT ÜST FİTİL / Sash Gasket	4 x SW
mt	EP60-04		KENET FİTİL / Central Locking Gasket	4 x SH
mt	EP60-05		KANAT FİTİL / Sash Gasket	(2SH)+(KASW)
mt	INT-01		KASA FİTİL / Frame Gasket	(2FH) + FW
mt	KF 67-600		FIRÇA FİTİL / Brush Gasket - 6mm	8xSH
mt	KF 67-700		FIRÇA FİTİL / Brush Gasket - 7mm	(2FH)+(2FW)+(2CW)

### AKSESUARLAR / ACCESSORIES

MİK/AR / Unit	KOD / Code	PROFİL ÇİZİMİ / Drawing	PROFİL TANIMI / Description	KESİM ÖLÇÜSÜ / Cutting Dimensions
2 Adet / Pcs	MO60-01		ALT KENET KAPAĞI / Innerlock Profile Cap-Bottom	
2 Adet / Pcs	MO60-02		ÜST KENET KAPAĞI / Innerlock Profile Cap-Top	
2 Adet / Pcs	MO60-03		MO60-10 ALT KAPAK PROFİLİ / Bottom Cover Profile	
2 Adet / Pcs	MO60-04		MO60-10 ÜST KAPAK PROFİLİ / Top Cover Profile	
2 Adet / Pcs	MO60-05D		ALT HAVYA KESİCİ / Central Sealing - Bottom	
2 Adet / Pcs	MO60-06D		ÜST HAVYA KESİCİ / Central Sealing - Top	
2 Adet / Pcs	MO60-12		ADAPTÖR KAPAĞI / Adapter Cover	
8 Adet / Pcs	MO60-13		KANAT DENGELEME PASTİSİ / Sash Stabilization Spacer	
4 Adet / Pcs	LS60CB 3660		KANAT SABİTLEME PARÇASI / Sash Fixing Part	
32 Adet / Pcs	ASISB 19.1		KÖŞE GÖNYESİ / Corner Alignment	
8 Adet / Pcs	ASIFB 1126		KÖŞE TAKOZU veya PİVALİ BAĞLI ANTI / Corner Joint Press or Pin	
8 Adet / Pcs	ASIKT 1126		KÖŞE TAKOZU / Pres Corner Joint	
8 Adet / Pcs	ASIKT 1429		KÖŞE TAKOZU / Pres Corner Joint	
16 Adet / Pcs	ASIKT 2307		KÖŞE TAKOZU / Pres Corner Joint	
1 Takım / Set	LS60AKETD		KALDIR-SÜR MEKANİZMASI / Lift&Slide Mechanism	



## NORMAL SÜRME 2 HAREKETLİ KANAT KESİM ÖLÇÜLERİ

### 2 SLIDING SASHES CUTTING SIZE FOR NORMAL SLIDING

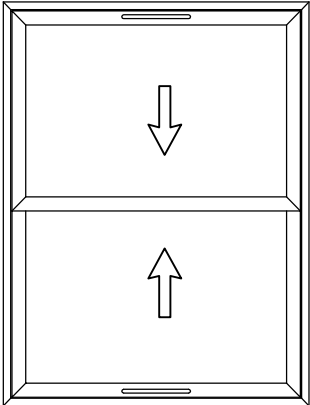
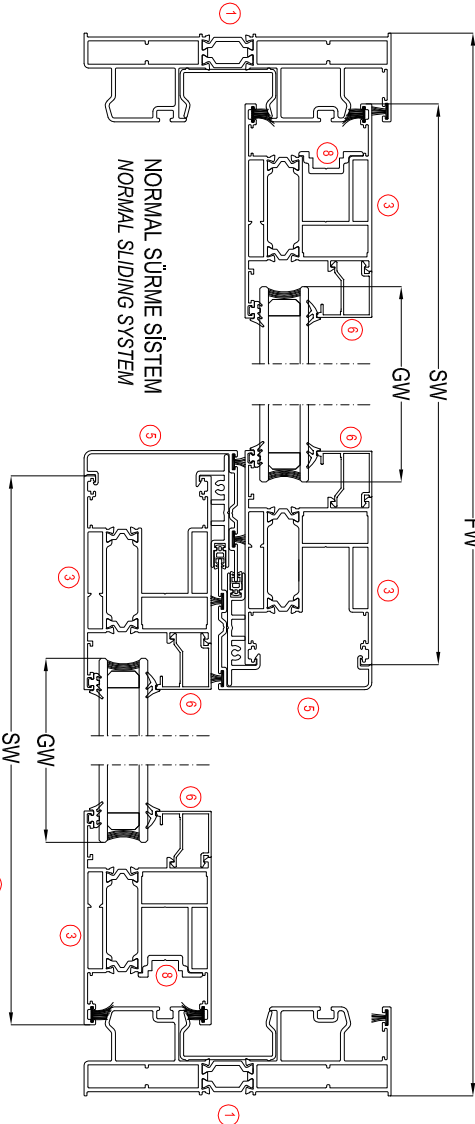

CAM KESİM ÖLÇÜLERİ / GLASS CUTTING SIZES		
KOD / Code	TANIMI / Description	KESİM ÖLÇÜSÜ / Cutting Dimensions
GW	CAM GENİŞLİK / Sash Glass Width	GW=SW-168mm
GH	CAM YÜKSEKLİK / Sash Glass Height	GH=SH-168mm

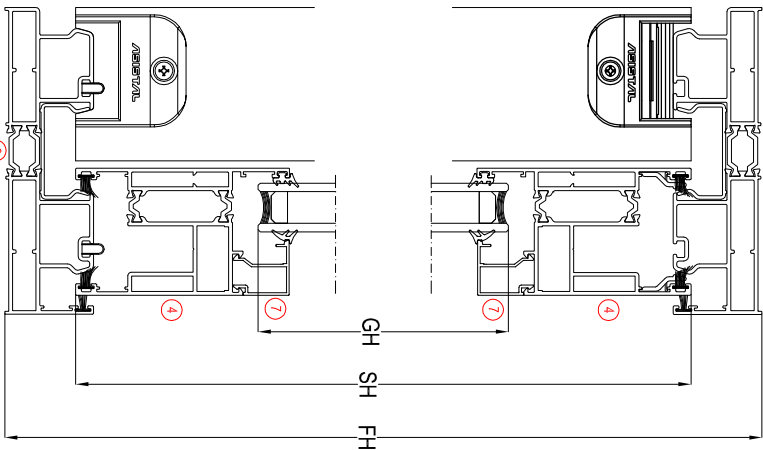

#### PROFİLLER / PROFILES

NO / Number	ADET / Unit	KOD / Code	PROFİL ÇİZİMİ / Drawing	PROFİL TANIMI / Description	KESİM ÖLÇÜSÜ / Cutting Dimensions
1	2	LS60 02		DÜŞEY KASA PROFİLİ / Vertical Frame Profile	FH
2	2	LS60 02		YATAY KASA PROFİLİ / Horizontal Frame Profile	FW
3	4	LS60 11		DÜŞEY KANAT PROFİLİ / Vertical Sash Profile	SH=FH-67mm
4	4	LS60 11		YATAY KANAT PROFİLİ / Horizontal Sash Profile	SW=FW-2*11,1mm
5	2	LS60 42		KENET PROFİLİ / Central Locking Profile	LS40 42=SH
6	4	11_026		DÜŞEY CAM ÇİTASI / Vertical Glazing Bead	G1=SH-202mm
7	4	11_026		YATAY CAM ÇİTASI / Horizontal Glazing Bead	G2=SW-158mm
8	2	LS60 44		İSPANVOLET KİLİTLEME KANAL PROFİLİ / Multi Lock Profile	SH - 500mm
PVC	2	MO60-10		KENET PVC PROFİLİ / Central Locking PVC Profile	SH
PVC	2	MO60-08		YATAY KASA KANAL PVC / Horizontal PVC Channel Profile	FW
PVC	2	MO60-08		YATAY KASA KANAL PVC / Horizontal PVC Channel Profile	FH
PVC	2	ASHHR 01		ÇELİK RAY PROFİLİ / Steel Rail Profile	FW-68mm

#### FİTİLLER / GASKETS

MİKTAR / Unit	KOD / Code	PROFİL ÇİZİMİ / Drawing	PROFİL TANIMI / Description	KESİM ÖLÇÜSÜ / Cutting Dimensions
mtl	EP-101		DİŞ CAM FİTİLİ / Outer Glazing Gasket	4x(G1+G2)
mtl	EP-201		İÇ CAM FİTİLİ / Inner Glazing Gasket	4x(G1+G2)
mtl	EP60-04		KENET FİTİLİ / Central Locking Gasket	2 x SH
mtl	INT-101		KASA FİTİLİ / Frame Gasket	4x(FH) + 2x(FW)
mtl	KF 67-600		FİRÇA FİTİLİ / Brush Gasket - 6mm	4 x SH
mtl	KF 67-700		FİRÇA FİTİLİ / Brush Gasket - 7mm	2x(FH)+2x(FW)
mtl	KF 67-1000		FİRÇA FİTİLİ / Brush Gasket - 10mm	4x(SH)+4x(SW)

#### AKSESUARLAR / ACCESSORIES

2 Adet / Pcs	MO60-01		ALT KENET KAPAĞI / Inerlock Profile Cap-Bottom	
2 Adet / Pcs	MO60-02		ÜST KENET KAPAĞI / Inerlock Profile Cap-Top	
2 Adet / Pcs	MO60-03		MO60-10 ALT KAPAK PROFİLİ / Bottom Cover Profile	
2 Adet / Pcs	MO60-04		MO60-10 ÜST KAPAK PROFİLİ / Top Cover Profile	
2 Adet / Pcs	MO60-08G		ÜST-HAVA KESİCİ / Central Sealing - Top	
8 Adet / Pcs	MO60-13		KANAT DENGELEME PLASTİĞİ / Sash Stabilization Spacer	
28 Adet / Pcs	AS-SB 19.1		KÖŞE GÖNYESİ / Corner Alignment	
8 Adet / Pcs	ASHP9 1126		KÖŞE TAKOZU veya PİVALİ BAĞLANTI / Corner Joint Pres or Pin	
8 Adet / Pcs	ASHKT 1429		KÖŞE TAKOZU / Pres Corner Joint	
16 Adet / Pcs	ASHKT 2307		KÖŞE TAKOZU / Pres Corner Joint	
4 Adet / Pcs	AS-SR 04		İKİLİ RULMAN / Double Roller	
2 Adet / Pcs	AS-HSP 15.3		İSPANVOLET KİLİTLEME / Multi Point Lock	
6 Adet / Pcs	AS-HSP K03		İSPANVOLET KİLİT KARŞILIĞI / Multi Point Strike	
2 Adet / Pcs	AS-SWH 002		İSPANVOLET KİLİTLEME KOL / Window Handle	

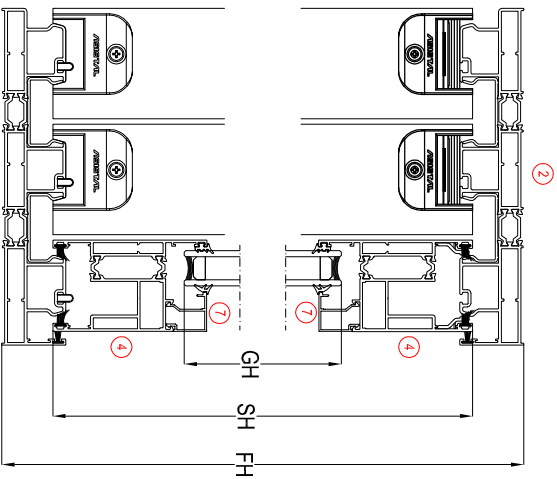
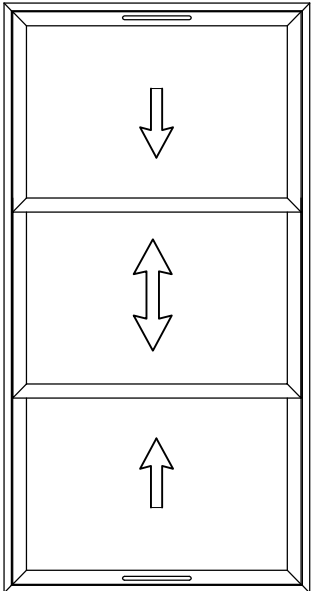
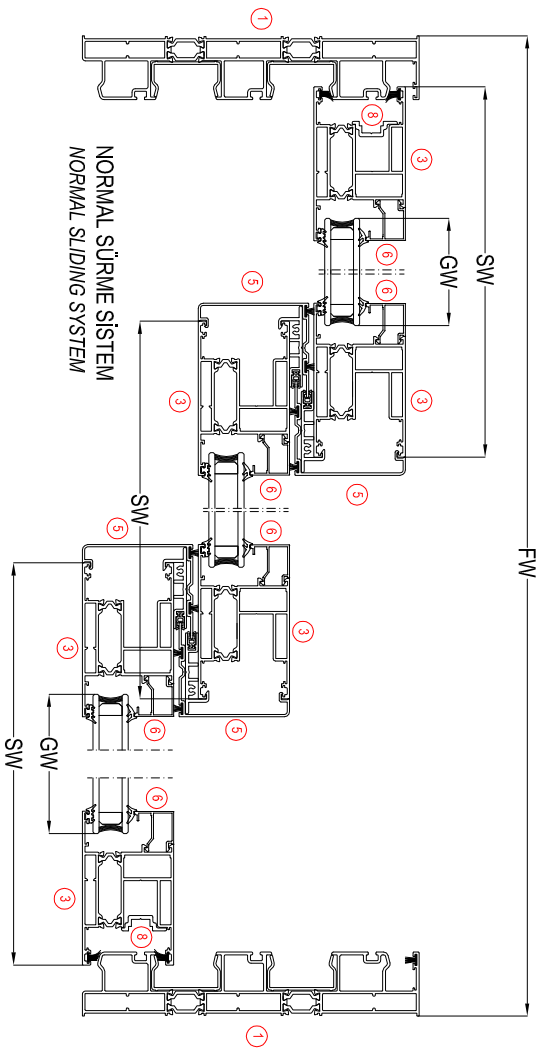

#### PROFİLLER / PROFILES

NO / Number	ADET / Unit	KOD / Code	PROFİL ÇİZİMİ / Drawing	PROFİL TANIMI / Description	KESİM ÖLÇÜSÜ / Cutting Dimensions
1	2	LS60 03		DÜŞEY KASA PROFİLİ / Vertical Frame Profile	FH
2	2	LS60 03		YATAY KASA PROFİLİ / Horizontal Frame Profile	FW
3	6	LS60 11		DÜŞEY KANAT PROFİLİ / Vertical Sash Profile	SH+FH+7mm
4	6	LS60 11		YATAY KANAT PROFİLİ / Horizontal Frame Profile	SW+FW+3*37 Z
5	4	LS60 42		KENET PROFİLİ / Central Looking Profile	LS40 42-5H
6	6	11.026		DÜŞEY CAM ÇITASI / Vertical Glazing Bead	G+KSH+222mm
7	6	11.026		YATAY CAM ÇITASI / Horizontal Glazing Bead	GZ-SW+156mm
8	2	LS60 44		İSPANVOLET KİLİTLEME KANAL PROFİLİ / Multi Lock Profile	SH - 500mm
PVC	4	MO60-10		KENET PVC PROFİL / Central Loading PVC Profile	SH
PVC	4	MO60-08		YATAY KASA KANAL PVC / Horizontal PVC Channel Profile	FW
PVC	4	MO60-08		YATAY KASA KANAL PVC / Horizontal PVC Channel Profile	FH
PVC	3	ASHNR 01		ÇELİK RAY PROFİL / Steel Rail Profile	FW+84mm

#### FİTİLLER / GASKETS

MİKTAR / Unit	KOD / Code	PROFİL ÇİZİMİ / Drawing	PROFİL TANIMI / Description	KESİM ÖLÇÜSÜ / Cutting Dimensions
mt	EP1-01		DIŞ CAM FİTİL / Outer Glazing Gasket	6x(G1+G2)
mt	EP2-01		İÇ CAM FİTİL / Inner Glazing Gasket	6x(G1+G2)
mt	EP60-04		KENET FİTİL / Central Looking Gasket	4 X SH
mt	INT1-01		KASA FİTİL / Frame Gasket	(6xFT) + (6xFW)
mt	KF 67-400		FİRÇA FİTİL / Brush Gasket - 6mm	8 X SH
mt	KF 67-700		FİRÇA FİTİL / Brush Gasket - 7mm	(2xFT)+(2xFW)
mt	KF 67-1000		FİRÇA FİTİL / Brush Gasket - 10mm	(4xSH)+(2xSW)

#### AKSESUARLAR / ACCESSORIES

4 Adet / Pcs	MO60-01		ALT KENET KAPAĞI / Inetlock Profile Cap-Bottom	
4 Adet / Pcs	MO60-02		ÜST KENET KAPAĞI / Inetlock Profile Cap-Top	
4 Adet / Pcs	MO60-03		MO60-10 ALT KAPAK PROFİLİ / Bottom Cover Profile	
4 Adet / Pcs	MO60-04		MO60-10 ÜST KAPAK PROFİLİ / Top Cover Profile	
4 Adet / Pcs	MO60-06G		ÜST HAVA KESİCİ / Central Sealing - Top	
12 Adet / Pcs	MO60-13		KANAT DENGELEME PLASTİĞİ / Sash Stabilization Spacer	
40 Adet / Pcs	ASH-SB-19.1		KÖŞE GÖNYESİ / Corner Alignment	
12 Adet / Pcs	ASH-PB 1126		KÖŞE TAKOZU veya PİMLİ BAĞLANTI / Corner Joint Pcs or Pim	
12 Adet / Pcs	ASHKT 1126		KÖŞE TAKOZU / Pcs Corner Joint	
24 Adet / Pcs	ASHKT 1429		KÖŞE TAKOZU / Pcs Corner Joint	
24 Adet / Pcs	ASHKT 2307		KÖŞE TAKOZU / Pcs Corner Joint	
6 Adet / Pcs	ASH-SF 04		İKİL RULMAN / Double Roller	
2 Adet / Pcs	ASHSP 15.3		İSPANVOLET KİLİTLEME / Multi Point Lock	
6 Adet / Pcs	ASHSP K03		İSPANVOLET KİLİT KARŞILIĞI / Multi Point Strike	
2 Adet / Pcs	ASH-WH 002		İSPANVOLET KİLİTLEME KOL / Window Handle	

#### CAM KESİM ÖLÇÜLERİ / GLASS CUTTING SIZES

KOD / Code	TANIMI / Description	KESİM ÖLÇÜSÜ / Cutting Dimensions
GW	CAM GENİŞLİK / Sash Glass Width	GW-SW+68mm
GH	CAM YÜKSEKLİK / Sash Glass Height	GH-SH+168mm



## 2 Lİ RAYDA 3 LÜ KANAT KESİM ÖLÇÜLERİ 3 SASHES CUTTING SIZE FOR DOUBLE RAIL FRAME

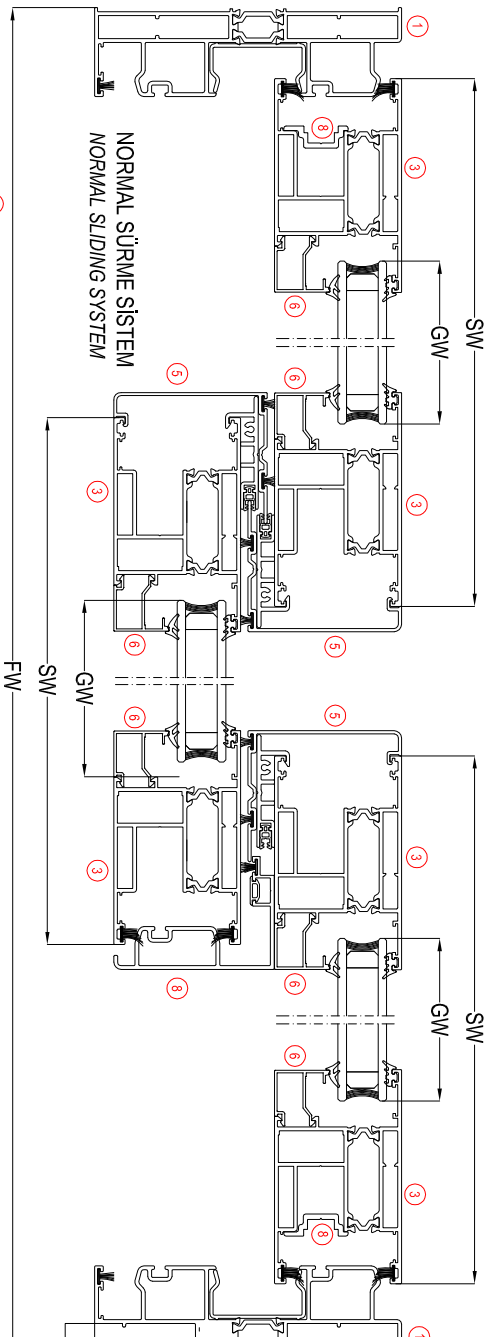

### PROFİLLER / PROFILES

NO / Number	ADET / Unit	KOD / Code	PROFİL ÇİZİMİ / Drawing	PROFİL TANIMI / Description	KESİM ÖLÇÜSÜ / Cutting Dimensions
1	2	LS80 02		DÜŞEY KASA PROFİLİ / Vertical Frame Profile	FH
2	2	LS80 02		YATAY KASA PROFİLİ / Horizontal Frame Profile	FV
3	6	LS80 11		DÜŞEY KANAT PROFİLİ / Vertical Sash Profile	SH=FH±7mm
4	6	LS80 11		YATAY KANAT PROFİLİ / Horizontal Frame Profile	SW=FV±37mm
5	4	LS80 42		KENET PROFİLİ / Central Locking Profile	LS40 42±SH
6	6	11_028		DÜŞEY CAM ÇITASI / Vertical Glazing Bead	G1±SH±202mm
7	6	11_028		YATAY CAM ÇITASI / Horizontal Glazing Bead	G2±SW±159m
8	2	LS80 44		İSPANVOLET KİLİTLEMELERİ KANAL PROFİLİ / Multi Lock Profiles	SH - 500mm
8	1	LS80 43		3 LÜ KANAT ADAPTOR PROFİLİ / Adapter Profile	FH±8mm
PVC	3	MO60-10		KENET PVC PROFİLİ / Central Locking PVC Profile	SH
PVC	2	MO60-08		YATAY KASA KANAL PVC / Horizontal PVC Channel Profile	FV
PVC	2	MO60-08		YATAY KASA KANAL PVC / Horizontal PVC Channel Profile	FH
PVC	2	ASHNR 01		ÇELİK RAY PROFİLİ / Steel Rail Profile	FV±8mm

### CAM KESİM ÖLÇÜLERİ / GLASS CUTTING SIZES

KOD / Code	TANIMI / Description	KESİM ÖLÇÜSÜ / Cutting Dimensions
GW	CAM GENİŞLİK / Sash Glass Width	GW±SW±168mm
GH	CAM YÜKSEKLİK / Sash Glass Height	GH±SH±168mm

### FİTİLLER / GASKETS

MİKTAR / Unit	KOD / Code	PROFİL ÇİZİMİ / Drawing	PROFİL TANIMI / Description	KESİM ÖLÇÜSÜ / Cutting Dimensions
mt	EP101		DİŞ CAM FİTİLİ / Outer Glazing Gasket	6x(G1+G2)
mt	EP201		İÇ CAM FİTİLİ / Inner Glazing Gasket	6x(G1+G2)
mt	EP80-04		KENET FİTİLİ / Central Locking Gasket	3 x SH
mt	INT1-01		KASA FİTİLİ / Frame Gasket	(4xFH) + (2xV)
mt	INT2-02		KANAL FİTİLİ / Adapter Gasket	1xSH
mt	KF 67-800		FİRÇA FİTİLİ / Brush Gasket - 6mm	6 x SH
mt	KF 67-700		FİRÇA FİTİLİ / Brush Gasket - 7mm	(2xFH)+(2xV)
mt	KF 67-1000		FİRÇA FİTİLİ / Brush Gasket - 10mm	(6xSH)+(2xV)

### AKSESUARLAR / ACCESSORIES

3 Adet / Pcs	MO60-01		ALT KENET KAPPAĞI / Innebox Profile Cap-Bottom	
3 Adet / Pcs	MO60-02		ÜST KENET KAPPAĞI / Innebox Profile Cap-Top	
3 Adet / Pcs	MO60-03		MO60-10 ALT KAPPAK PROFİLİ / Bottom Cover Profile	
3 Adet / Pcs	MO60-04		MO60-10 ÜST KAPPAK PROFİLİ / Top Cover Profile	
4 Adet / Pcs	MO60-06G		ÜST HAVALA KESİCİ / Central Sealing - Top	
12 Adet / Pcs	MO60-13		KANAT DENGELERME PASTİĞİ / Sash Stabilization Spacer	
40 Adet / Pcs	ASH-S9 19.1		KÖŞE GÖNYESİL / Corner Alignment	
8 Adet / Pcs	ASH-PB 1126		KÖŞE TAKOZU veya FİMLİ BAĞLANTI / Corner Joint	
12 Adet / Pcs	ASH-KT 1126		KÖŞE TAKOZU / Pres Corner Joint	
24 Adet / Pcs	ASH-KT 2307		KÖŞE TAKOZU / Pres Corner Joint	
2 Adet / Pcs	LS80-08 3580		KANAT SABİTLEMELERİ PARÇASI / Sash Fixing	
4 Adet / Pcs	ASH-SR 04		İKİLİ RULMAN / Double Roller	
2 Adet / Pcs	ASH-SP 15.3		İSPANVOLET KİLİTLEMELERİ / Multi Point Lock	
6 Adet / Pcs	ASH-SP K03		İSPANVOLET KİLİT KARSILICI / Multi Point Strike	
2 Adet / Pcs	ASH-WH 002		İSPANVOLET KİLİTLEMELERİ KOL / Window Handle	

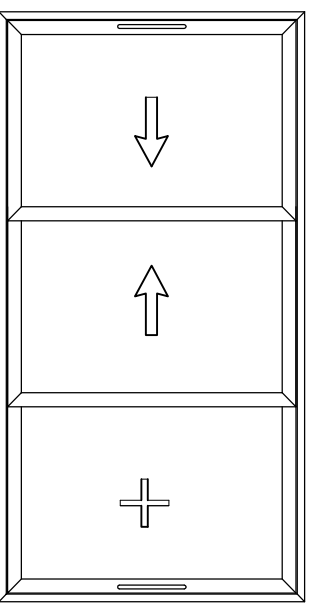

4 LÜ KANAT KESİM ÖLÇÜLERİ  
4 SLIDING SASHES CUTTING SIZE

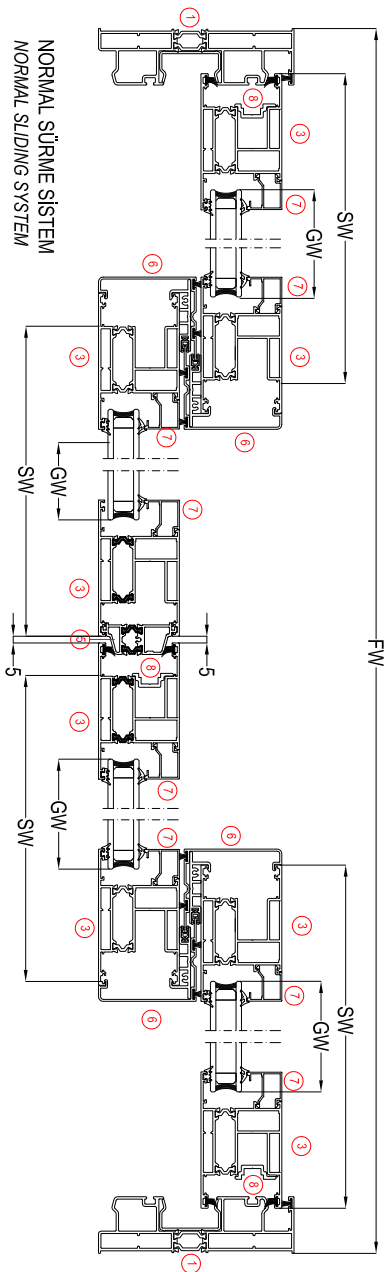

CAM KESİM ÖLÇÜLERİ / GLASS CUTTING SIZES		
KOD / Code	TANIMI / Description	KESİM ÖLÇÜSÜ / Cutting Dimensions
GW	CAM GENİŞLİK / Sash Glass Width	GW=SH-17mm
GH	CAM YÜKSEKLİK / Sash Glass Height	GH=SH-172mm

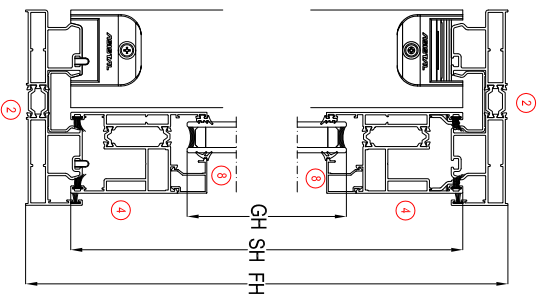
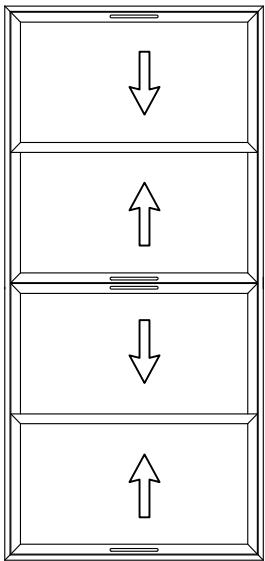

PROFİLLER / PROFILES

NO / Number	ADET / Unit	KOD / Code	PROFİL ÇİZİMİ / Drawing	PROFİL TANIMI / Description	KESİM ÖLÇÜSÜ / Cutting Dimensions
1	2	LS60 04		DÜŞEY KASA PROFİLİ / Vertical Frame Profile	FH
2	2	LS60 04		YATAY KASA PROFİLİ / Horizontal Frame Profile	FW
3	8	LS60 11		DÜŞEY KANAT PROFİLİ / Vertical Sash Profile	SH=Hx76mm
4	8	LS60 11		YATAY KANAT PROFİLİ / Horizontal Sash Profile	SW=FWx28,6mm
5	1	LS60 11		ADAPTÖR PROFİLİ / Adapter Profile	LS60 4xSHx30mm
6	4	LS60 42		KENET PROFİLİ / Central Locking Profile	LS60 42xSH
7	8	11_026		DÜŞEY CAM ÇITASI / Vertical Glazing Bead	GH=SHx202mm
8	8	11_026		YATAY CAM ÇITASI / Horizontal Glazing Bead	GZ=SWx158mm
8	3	LS60 44		İSPANVOLET KİLİTLEMİYE KANAL PROFİLİ / Multi Lock Profile	SH - 500mm
PVC	4	MO60-10		KENET PVC PROFİLİ / Central Locking PVC Profile	SH
PVC	2	MO60-08		YATAY KASA KANAL PVC / Horizontal PVC Channel	SW
PVC	2	MO60-08		DÜŞEY KASA KANAL PVC / Vertical PVC Channel	SH
	2	ASHNR 01		ÇELİK RAY PROFİLİ / Steel Rail Profile	FWx48mm

FİTİLLER / GASKETS

MİKTAR / Unit	KOD / Code	PROFİL ÇİZİMİ / Drawing	PROFİL TANIMI / Description	KESİM ÖLÇÜSÜ / Cutting Dimensions
mt	EP-101		DİŞ CAM FİTİL / Outer Glazing Gasket	8x(G1+G2)
mt	EP2-01		İÇ CAM FİTİL / Inner Glazing Gasket	8x(G1+G2)
mt	EP60-04		KENET FİTİLİ / Central Locking Gasket	4 x SH
mt	EP60-05		KANAT FİTİLİ / Sash Gasket	2xSH
mt	INTT-01		KASA FİTİLİ / Frame Gasket	(4xFH) + (2x FW)
mt	KF 67-600		FIRÇA FİTİL / Brush Gasket - 6mm	8xSH
mt	KF 67-700		FIRÇA FİTİL / Brush Gasket - 7mm	(2xFH) + (2xFW)
mt	KF 67-1000		FIRÇA FİTİL / Brush Gasket - 10mm	(6xSH) + (6xSW)

AKSESUARLAR / ACCESSORIES

4 Adet / Pcs	MO60-01		ALT KENET KAPAĞI / Innerlock Profile Cap-Bottom	
4 Adet / Pcs	MO60-02		ÜST KENET KAPAĞI / Innerlock Profile Cap-Top	
4 Adet / Pcs	MO60-03		MO60-10 ALT KAPAK PROFİLİ / Bottom Cover Profile	
4 Adet / Pcs	MO60-04		MO60-10 ÜST KAPAK PROFİLİ / Top Cover Profile	
4 Adet / Pcs	MO60-06G		ÜST HAVA KESİCİ / Central Sealing - Top	
2 Adet / Pcs	MO60-12		ADAPTÖR KAPAĞI / Adapter Cover	
16 Adet / Pcs	MO60-13		KANAT DENGELEME PLASTİĞİ / Sash Stabilization Spacer	
52 Adet / Pcs	ASISB 19.1		KÖŞE GÖNYESİ / Corner Alignment	
8 Adet / Pcs	ASIPR 1126		KÖŞE TAKOZU veya PİVAL BAĞLANTI / Corner Joint Piece or Pin	
16 Adet / Pcs	ASIKT 1429		KÖŞE TAKOZU / Pias Corner Joint	
32 Adet / Pcs	ASIKT 2307		KÖŞE TAKOZU / Pias Corner Joint	
8 Adet / Pcs	ASISR 04		İKİLİ RULMAN / Double Roller	
3 Adet / Pcs	ASISP 15.3		İSPANVOLET KİLİTLEMİYE / Multi Point Lock	
9 Adet / Pcs	ASISP K03		İSPANVOLET KİLİT KARŞILIGI / Multi Point Strike	
4 Adet / Pcs	ASIAHT 002		İSPANVOLET KİLİTLEMİYE KOL / Window Handle	

## SABITLI KASADA 1 HAREKETLİ KANAT KESİM ÖLÇÜLERİ

### 1 SLIDING SASH IN FIXED FRAME CUTTING SIZE

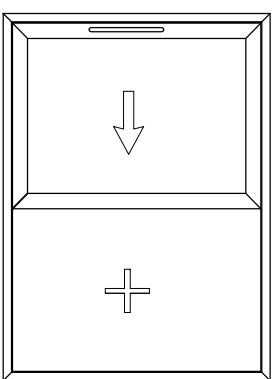
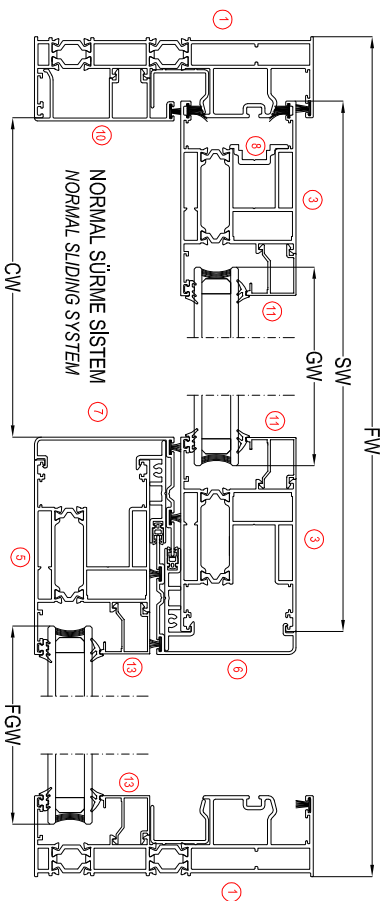

CAM KESİM ÖLÇÜLERİ / GLASS CUTTING SIZES		
KOD / Code	TANIMI / Description	KESİM ÖLÇÜSÜ / Cutting Dimensions
GW	HAREKETLİ KANAT CAM GENİŞLİK / Sash Glass Width	GW=SW+68mm
GH	HAREKETLİ KANAT CAM YÜKSEKLİK / Sash Glass Height	GH=SH+168mm
FGW	SABİT KISIM CAM GENİŞLİK / Fixed Glass Width	FGW=FW/2+12mm
FGH	SABİT KISIM CAM YÜKSEKLİK / Fixed Glass Height	FGH=FW/2+93mm

#### PROFİLLER / PROFILES

NO / Number	ADET / Unit	KOD / Code	PROFİL ÇİZİM / Drawing	PROFİL TANIMI / Description	KESİM ÖLÇÜSÜ / Cutting Dimensions
1	2	LS90 04		DÜŞEY KASA PROFİLİ / Vertical Frame Profile	FH
2	2	LS90 04		YATAY KASA PROFİLİ / Horizontal Frame Profile	FW
3	2	LS90 11		DÜŞEY KANAT PROFİLİ / Vertical Sash Profile	SH=FW-67mm
4	2	LS90 11		YATAY KANAT PROFİLİ / Horizontal Sash Profile	SW=FW/2-56,2mm
5	1	LS90 11		ORTA KAMIT PROFİLİ / Central Locking Profile	TH=FW-43mm
6	1	LS90 42		KENET PROFİLİ / Central Locking Profile	LSA 42=SH
7	1	LS90 42		ORTA KAMIT KENET PROFİLİ / Transom Cover	FH+43mm
8	1	LS90 31		ÜST KAPAK PROFİLİ / Top Cover Profile	OW=FW/2 - 53mm
9	1	LS90 32		ALT KAPAK PROFİLİ / Bottom Cover Profile	OW=FW/2 - 53mm
10	1	LS90 31		YAN KAPAK PROFİLİ / Side Cover Profile	CH=H - 88 mm
11	2	11_026		DÜŞEY CAM ÇİTASI / Vertical Glazing Bead	GT=SH - 202mm
12	2	11_026		YATAY CAM ÇİTASI / Horizontal Glazing Bead	GZ=SW - 156mm
13	2	11_026		SABİT DÜŞEY CAM ÇİTASI / Fixed Vertical Glazing Bead	GZ=H+47mm
14	2	11_026		SABİT YATAY CAM ÇİTASI / Fixed Horizontal Glazing Bead	GH=FW/2 - 102mm
15	1	LS90 44		İSPANYOLET KİLİTLİME KANAL PROFİLİ / Multi Lock Profile	SH - 50mm
PVC	2	MO90-10		KENET PVC PROFİLİ / Central Locking PVC Profile	SH
PVC	2	MO90-07		YATAY KASA KANAL PVC / Horizontal PVC Channel Profile	FW
PVC	2	MO90-07		DÜŞEY KASA KANAL PVC / Vertical PVC Channel Profile	FH
1	1	ASHNR 01		ÇELİK RAY PROFİLİ / Steel Rail Profile	FW-34mm

#### FİTİLLER / GASKETS

MİKTAR / Unit	KOD / Code	PROFİL ÇİZİM / Drawing	PROFİL TANIMI / Description	KESİM ÖLÇÜSÜ / Cutting Dimensions
ml	EP1-01		DİŞ CAM FİTİL / Outer Glazing Gasket	2x(G1+G2-G3-G4)
ml	EP2-01		İÇ CAM FİTİL / Inner Glazing Gasket	2 x SH
ml	EP90-04		KENET FİTİLİ / Central Locking Gasket	2x(FH) + FW
ml	INT-01		KASA FİTİLİ / Frame Gasket	4xSH
ml	KF 67-600		FRÇA FİTİL / Brush Gasket - 6mm	2x(FH) - 2x(FW) + CH + 2 x(CW)
ml	KF 67-700		FRÇA FİTİL / Brush Gasket - 7mm	2x(FH) - 2x(FW) + CH + 2 x(CW)
ml	KF 67-1000		FRÇA FİTİL / Brush Gasket - 10mm	2xSH + 4x(SW)

#### AKSESUARLAR / ACCESSORIES

1 Adet / Pcs	MO90-01		ALT KENET KAPAKI / Innerlock Profile Cap-Bottom	
1 Adet / Pcs	MO90-02		ÜST KENET KAPAKI / Innerlock Profile Cap-Top	
1 Adet / Pcs	MO90-03		MO90-10 ALT KAPAK PROFİLİ / Bottom Cover Profile	
1 Adet / Pcs	MO90-04		MO90-10 ÜST KAPAK PROFİLİ / Top Cover Profile	
2 Adet / Pcs	MO90-08D		ÜST HAVALA KESİCİ / Central Sealing - Top	
4 Adet / Pcs	MO90-13		KANAT DENGECİME PLASTİĞİ / Sash Stabilization Spacer	
2 Adet / Pcs	LS90-08 890		KANAT SABİTLEMİNE PAKÇISI / Sash Flang Part	
20 Adet / Pcs	ASH-SB 19.1		KÖŞE GÖNYESİ / Corner Alignment	
8 Adet / Pcs	ASH-PP 1128		KÖŞE TAKOZU veya FİTİL BAĞLANTI / Corner Joint Press or Pin	
4 Adet / Pcs	ASHKT 1429		KÖŞE TAKOZU / Pres Corner Joint	
8 Adet / Pcs	ASHKT 2307		KÖŞE TAKOZU / Pres Corner Joint	
2 Adet / Pcs	ASH-SR 04		KİLİ RULMANI / Double Roller	
1 Adet / Pcs	ASHSP 6.3		İSPANYOLET KİLİTLİME / Multi Point Lock	
3 Adet / Pcs	ASHSP 003		İSPANYOLET KİLİT KARSILIĞI / Multi Point Strike	
1 Adet / Pcs	ASHWH 002		İSPANYOLET KİLİTLİME KOL / Window Handle	

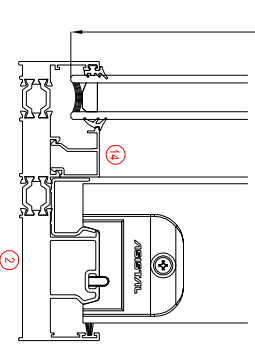
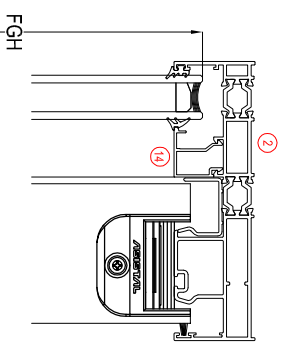
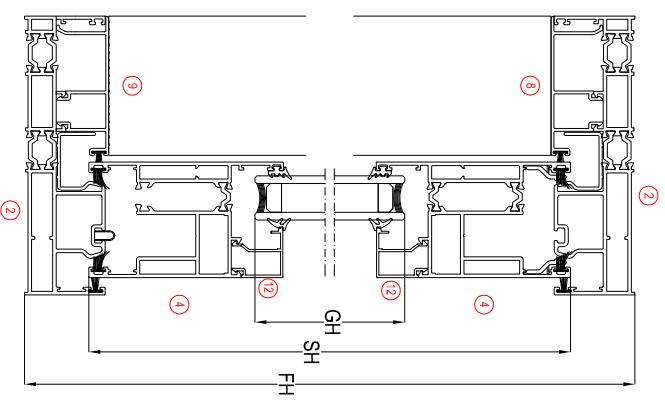

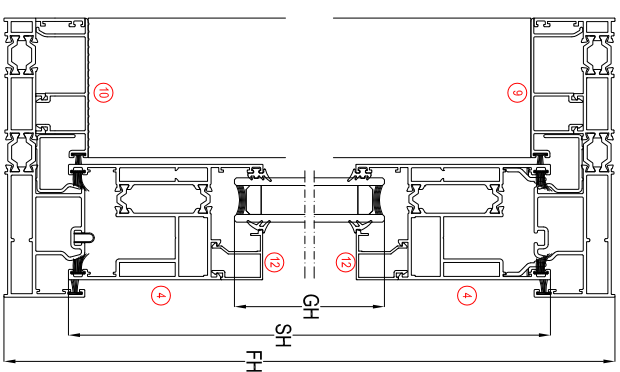
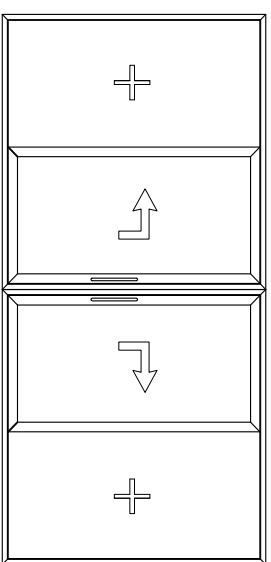
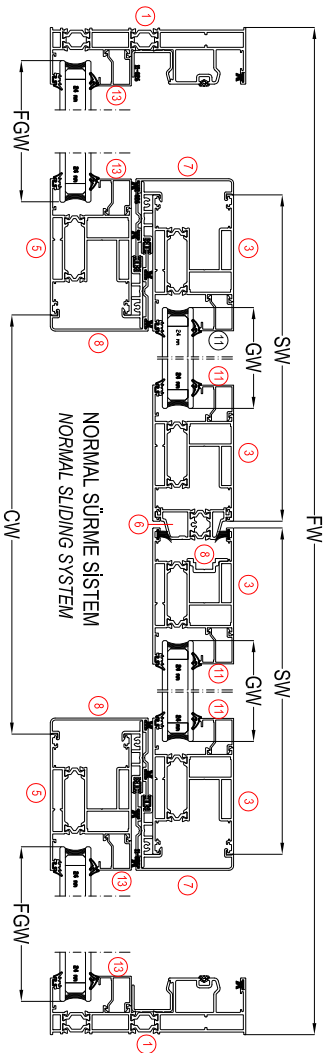

PROFİLLER / PROFILES

NO / Number	ADET / Unit	KOD / Code	PROFİL ÇİZİMİ / Drawing	PROFİL TANIMI / Description	KESİM ÖLÇÜSÜ / Cutting Dimensions
1	2	LS60 04		DÜŞEY KASA PROFİLİ / Vertical Frame Profile	FH
2	2	LS60 04		YATAY KASA PROFİLİ / Horizontal Frame Profile	EW
3	4	LS60 11		DÜŞEY KANAT PROFİLİ / Vertical Sash Profile	SH=EH-7mm
4	4	LS60 11		YATAY KANAT PROFİLİ / Horizontal Sash Profile	SW=FW+25,4mm
5	2	LS60 11		ORTA KAYIT PROFİLİ / Transom Locking Profile	TH=EH-4,3mm
6	1	LS60 41		ADAPTÖR PROFİLİ / Adapter Profile	LS60 41-SH-60mm
7	2	LS60 42		KENET PROFİLİ / Central Locking Profile	LS60 42-SH
8	2	LS60 42		ORTA KAYIT KENET PROFİLİ / Transom Cover	FH-43mm
9	1	LS60 31		ÜST KAPAK PROFİLİ / Top Cover Profile	CW=FW/2-146mm
10	1	LS60 32		ALT KAPAK PROFİLİ / Bottom Cover Profile	CW=FW/2-146mm
11	4	11_026		DÜŞEY CAM ÇİTASI / Vertical Glazing Bead	G1-SH-420,3mm
12	4	11_026		YATAY CAM ÇİTASI / Horizontal Glazing Bead	G2-SH-459mm
13	4	11_026		SABİT DÜŞEY CAM ÇİTASI / Fixed Vertical Glazing Bead	G3=EH-7mm
14	4	11_026		SABİT YATAY CAM ÇİTASI / Fixed Horizontal Glazing Bead	G4=FW/4-10mm
15	1	LS60 44		İSPANVOLET KİLİTLİ ENME KANAL PROFİLİ / Multi Lock Profile	SH - 500mm
PVC 4		MO60-10		KENET PVC PROFİL / Central Locking PVC Profile	SH
PVC 2		MO60-07		YATAY KASA KANAL PVC / Horizontal PVC Channel	EW
PVC 2		MO60-07		DÜŞEY KASA KANAL PVC / Vertical PVC Channel	FH
PVC 1		ASH-NK-01		ÇELİK RAY PROFİLİ / Steel Rail Profile	FW-64mm

FİTİLLER / GASKETS

MİKTAR / Unit	KOD / Code	PROFİL ÇİZİMİ / Drawing	PROFİL TANIMI / Description	KESİM ÖLÇÜSÜ / Cutting Dimensions
mt	EP-01		DİŞ CAM FİTİL / Outer Glazing Gasket	4x(G1+G2+G3+G4)
mt	EP-04		İÇ CAM FİTİL / Inner Glazing Gasket	4 x SH
mt	EP-05		KANAT FİTİL / Sash Gasket	2xSH
mt	INT-01		KASA FİTİL / Frame Gasket	2x(FH) + FW
mt	KF 67-400		FRİÇA FİTİL / Brush Gasket - 6mm	8xSH
mt	KF 67-700		FRİÇA FİTİL / Brush Gasket - 7mm	2x(FH)+(2xFW)+(2xCW)
mt	KF 67-1000		FRİÇA FİTİL / Brush Gasket - 10mm	2xSH+8xSW

AKSESUARLAR / ACCESSORIES

MİKTAR / Pcs	KOD / Code	PROFİL ÇİZİMİ / Drawing	AKSESUAR TANIMI / Description
2 Adet / Pcs	MO60-01		ALT KENET KAPAĞI / Innerlock Profile Cap-Bottom
2 Adet / Pcs	MO60-02		ÜST KENET KAPAĞI / Innerlock Profile Cap-Top
2 Adet / Pcs	MO60-03		MO60-10 ALT KAPAK PROFİLİ / Bottom Cover Profile
2 Adet / Pcs	MO60-04		MO60-10 ÜST KAPAK PROFİLİ / Top Cover Profile
4 Adet / Pcs	MO60-0D		ÜST HANA KESİCİ / Central Sealing - Top
2 Adet / Pcs	MO60-12		ADAPTÖR KAPAĞI / Adapter Cover
8 Adet / Pcs	MO60-13		KANAT DENGELERİNE PLASTİĞİ / Sash Stabilization Spacer
4 Adet / Pcs	LS60-0B 3560		KANAT SABİTLERİNE PARÇASI / Sash Fixing Part
32 Adet / Pcs	ASH-SB 18,1		KÖŞE ÇÖNYESİ / Corner Alignment
8 Adet / Pcs	ASH-PTB 1126		KÖŞE TAKOZU veya FİNAL BAĞLANTI / Corner Joint Press or Pin
8 Adet / Pcs	ASH-KT 1429		KÖŞE TAKOZU / Pcs Corner Joint
16 Adet / Pcs	ASH-KT 2207		KÖŞE TAKOZU / Pcs Corner Joint
4 Adet / Pcs	ASH-SR 04		İKİLİ RULMAN / Double Roller
1 Adet / Pcs	ASH-SP 15,3		İSPANVOLET KİLİTLERİNE / Multi Point Lock
3 Adet / Pcs	ASH-SP 103		İSPANVOLET KİLİT KARSILIĞI / Multi Point Strike
2 Adet / Pcs	ASH-WH 102		İSPANVOLET KİLİTLERİNE KOL / Window Handle

KOD / Code	TANIMI / Description	KESİM ÖLÇÜSÜ / Cutting Dimensions
GW	HAREKETLİ KANAT CAM GENİŞLİK / Sash Glass Width	GW=SW+172mm
GH	HAREKETLİ KANAT CAM YÜKSEKLİK / Sash Glass Height	GH=SH+172mm
FGW	SABİT KISIM CAM GENİŞLİK / Fixed Glass Width	FGW=FW+4 - 57mm
FGH	SABİT KISIM CAM YÜKSEKLİK / Fixed Glass Height	FGH=FW+64mm

